

 **KENWOOD**

**2m ALL MODE  
TRANSCEIVER**

**Model TS-700**



**OPERATING MANUAL**

# TS-700 OPERATING MANUAL

## CONTENTS

	TS-700 SPECIFICATIONS .....	3
SECTION 1.	TS-700 FEATURES .....	4
SECTION 2.	INSTALLATION .....	6
	2-1. Accessories	
	2-2. Operating Location	
	2-3. Power Supply Connection	
	2-4. Antenna Connection	
	2-5. Microphone	
	2-6. Sending Key	
	2-7. External Speaker Connection	
	2-8. Vox Connector	
	2-9. Mic Hook	
SECTION 3.	OPERATING CONTROLS .....	8
	3-1. Front Panel Controls	
	3-2. Rear Panel Controls	
SECTION 4.	OPERATING INSTRUCTION .....	13
	4-1. Preparation	
	4-2. Receiver Tuning	
	4-3. Transmitter Tuning	
	4-4. RPT Operation	
	4-5. Push-To-Talk Operation	
	4-6. Operation With Fixed Channels	
	4-7. Mobile Operation With External DC Power Supply	
	4-8. RIT (Receiver Incremental Tuning)	
	4-9. Reading The Frequencies	
	4-10. Frequency Calibration	
SECTION 5.	CIRCUIT DESCRIPTION .....	19
	5-1. Block Diagram	
	5-2. Unitized Circuits	
SECTION 6.	ALIGNMENT .....	20
SECTION 7.	TROUBLESHOOTING .....	21
	TOP & BOTTOM VIEW OF THE TS-700 .....	22
	TS-700 SCHEMATIC DIAGRAM .....	23

# TS-700 SPECIFICATIONS

FREQUENCY RANGE	144 BAND (T, R) 144 ~ 145 MHz 145 BAND (T, R) 145 ~ 146 MHz RPT BAND R 145 ~ 146 MHz T 144.4 ~ 145.4 MHz
MODE	SSB, FM, CW, AM
POWER OUTPUT	10 watts for SSB, CW and FM 3 watts for AM
ANTENNA IMPEDANCE	50 ohms (unbalanced)
CARRIER SUPPRESSION	Carrier better than 40 dB down from the output signal
SIDEBAND SUPPRESSION	Unwanted sideband is better than 40dB down from the output signal
SPURIOUS RADIATION	Less than -60 dB
MAX. FREQUENCY DEVIATION (FM)	±10 kHz and 5 kHz, ±5 kHz when shipped
MODULATION	Balanced modulation for SSB Variable reactance frequency shift for FM Low power modulation for AM
MICROPHONE	500-ohm dynamic microphone
AUDIO FREQUENCY RESPONSE	500 to 2500 Hz, within -6 dB
RPT TONE FREQUENCY	1750 Hz
RECEIVE CIRCUITRY	Single superheterodyne for SSB, CW and AM Double superheterodyne for FM
INTERMEDIATE FREQUENCY	10.7 MHz for SSB, CW and AM 10.7 MHz, first IF; 455 kHz, second IF, for FM
RECEIVER SENSITIVITY	Less than 0.5 $\mu$ V for 10 dB S/N for SSB and CW Less than 1 $\mu$ V for 26 dB S/N for FM Less than 2 $\mu$ V for 10 dB S/N for AM
IMAGE RATIO	Image frequency better than 60 dB down from the output signal
IF REJECTION	If frequency is 60 dB or more down from output signal
BANDPASS WIDTH	More than 2.4 kHz at 6 dB down for SSB, CW and AM More than 20 kHz at 6 dB down for FM
RECEIVER SELECTIVITY	Less than 4.8 kHz at 60 dB down for SSB, CW and AM Less than 40 kHz at 60 dB down for FM
SQUELCH SENSITIVITY	0.5 $\mu$ V
AUDIO OUTPUT	More than 2 watts across 8 $\Omega$ load (10% distortion)
AUDIO OUTPUT IMPEDANCE	8 ohms
FREQUENCY STABILITY	Within 200 Hz during any 30 minute period after warmup Within ±4 kHz during the first hour after 1 minute of warmup
POWER REQUIREMENTS	AC 120/220 volts, 50/60 Hz; DC 12 ~ 16 volts (13.8 volts as reference)
POWER CONSUMPTION	95 watts (AC 220 V), 4A (DC 13.8 V) for full power transmission 45 watts (AC 220 V), 0.8 A (DC 13.8 V) for no-signal reception
DIMENSIONS AND WEIGHT	10-15/16" (278 mm) wide x 4-7/8" (124 mm) high x 12-9/16" (320 mm) deep 24.2 lbs (11 kg)

## SECTION 1. TS-700 FEATURES

1. A fully solid-state, all-mode amateur transceiver, the Model TS-700 provides high-quality communications on SSB, FM, AM and CW in the 144-MHz band.
2. It operates with dual power supply, AC and DC, and is designed for two duties—STATIONARY and MOBILE—with emphasis on stationary duty.
3. The TS-700 is a highly sophisticated amateur radio transceiver with the frequency coverage in two bands, 144 to 145 MHz, and 145 to 146 MHz, respectively. Also included in the equipment are a built-in VFO circuit and an additional provision for RPT operation with the frequency coverage from 145 to 146 MHz for reception, and 144.4 to 145.4 MHz for transmission.
4. A newly developed two-speed dial mechanism facilitates tuning: MAIN TUNING knob (inner) for closer tuning covers a change of 25 kHz by one complete rotation; QUICK (COARSE) TUNING knob (outer) covers a change of 100 kHz similarly. You can tune in quickly with pin-point accuracy—the feature which will prove very useful in receiving single-sideband (SSB) signals.
5. MAIN DIAL is graduated to provide readings accurate to 1 kHz, presenting a circular (360 degrees) scale from zero to 100 kHz. SUB-DIAL is a similar scale graduated in intervals of 50 kHz to cover a total range of 1 MHz for a complete rotation.
6. A total of 11 fixed oscillator circuits (to be loaded with optional crystals) are provided: these selective circuits are good for each of the two selective bands, 144 MHz and 145 MHz, so that you virtually have a total of 22 fixed channels, each for making available a certain operating frequency and closely select the operating frequency within the assigned band. Moreover, a channel-in-use indicating device is included to tell you visually which of the crystal-loaded channels is in service.
7. A noise blanker (NB) circuit of the type adopted in many other HF products of our make and widely acknowledge for excellent noise eliminating performance is included. Such pulse signals as those coming from automotive ignition systems are beautifully excluded from audio output.
8. For improve FM-mode operation, a squelch circuit of noise filter type is added to the FM unit.
9. A tuner which uses a voltage variable capacitor is built in the receiver RF stage to minimize cross-talk and spurious interferences, and a high “Q” tuning circuit in the antenna input stage for excellent selectivity.
10. A balanced-type mixer circuit based on the use of field-effect transistors (FET) has been adopted for the pre-mixer and heterodyne mixer. These mixers assure improved rejection of spurious signals during transmission.
11. The IF stage (SSB, AM, CW) is provided with a 6-element crystal filter. The use of wide-band and narrow-band ceramic filters assures outstanding selectivity during FM reception.
12. The built-in RF gain control is of threshold type and, as such, ensures an optimized S/N ratio at all times in receiving SSB signals.
13. Speaker output is free from distortion: this owes to the amplifier-type AGC circuit. Signals transmitted are accompanied by little or no splutter and free from distortion: this owes to the advanced ALC circuit. The AGC circuit comprises such time-constant elements that this constant is “slow” in SSB mode but “fast” in FM, AM or CW mode.
14. A marker signal circuit, operating with a high-precision crystal oscillator which runs at 1 MHz, is included to enable you to calibrate the tuning dial extremely accurately at the edge of a frequency band.
15. The “S” meter is of our proprietary type. Its indication does not go beyond and “over the scale” even when an unusually intense signal comes in, as in FM-mode operation. This property of the meter enables you to verify the FM center frequency at the face of this meter.

16. The TS-700 is equipped with a tone oscillator which produces a low-frequency beat tone at 1,750 Hz to call in a repeater station.
17. The ON-AIR lamp lights up when the transceiver shifts itself into transmitting state. This feature keeps you informed of the state of operation at all times.
18. A receiver incremental tuning circuit (RIT) is included as a means of fine tuning. This circuit is particularly useful in SSB and CW modes, and is effective whether you have selected the VFO or any of the 11 fixed channels.
19. The built-in speaker is a large 9 cm by 6 cm one. An extra jack is provided, so that you can drive an external speaker from it.
20. Two kinds of power supply are accepted: AC 120/220 volts (50 or 60 Hz) and DC 13.8 volts. Supply connection is simplified. A DC voltage multiplier of our own development is contained in the transceiver: this multiplier is exceptionally compact and has contributed much to the space-economy design of this model.
21. Significant improvements are embodied in the panel design for making this transceiver much easier to control and use. Dials and knobs are of more advanced type in visual and functional senses; meter illumination and pilot lighting are included by assuming nighttime use of the transceiver; and controls and connectors are laid out according to the principles of human engineering.
22. Visual aspects were taken as an important criterion in the designing of this transceiver, and have been worked out to present a sharp, high-quality appearance that this model has an appearance that bespeaks the advanced all-mode functions this model is capable of. Mechanical features too have been treated similarly, with particular emphasis on their reliability.
23. For assuring easier access to the internals, the transceiver enclosure or case is in two parts, complete with special mechanical details to allow the front control panel to be detached. The top half of the case too is detachable; and the rear panel and final-stage unit are so arranged that this unit can be removed as an individual component by and from the rear panel.
24. The handle is provided for easy carrying and handling of this transceiver.
25. A microphone is included among the standard accessories.

## SECTION 2. INSTALLATION

### 2-1. ACCESSORIES

The Model TS-700 transceiver is supplied standardly with the following accessories. Upon unpacking, check the accessories against the list:

	Quantity
Operating manual	1
RCA phono plugs	2
Feet with screws	2
Fuses: 1A (for AC220V)	1
2A (for DC 20V or AC120V)	1
5A (for DC cord)	1
Microphone, 500 ohm	1 With hook
AC power supply cord	1 With connector
DC power supply cord	1 With connector
VOX plug (installed)	1
Speaker plug	1

### 2-2. OPERATING LOCATION

As with any solid-state electronic equipment, the place of use must be discriminated with the TS-700, in order to avoid subjecting it to extremes of ambient conditions.

A well-ventilated, dry place, where the transceiver will not be exposed to direct sun, should be selected. Remember, the TS-700 has a heat sink in its rear panel: be sure to set up the transceiver in such a way as to provide some clearance between its bottom and the supporting surface. For better heat dissipation, keep it away from a wall. This precaution with respect to heat dissipation applies in particular to the TS-700 placed on the companion's seat in a car.

When you use the transceiver in a car, you may put it on the seat but be sure to secure some heat-dissipating clearances under and behind it and to make proper provisions for protecting it against shocks.

### 2-3. POWER SUPPLY CONNECTION

Switching between AC and DC is effected by replacing the power cord. Plug in the DC power cord (red-and-black) to connect the transceiver to a DC power supply source; use the other cord for connecting it to an AC power supply source.

The A-C POWER SELECTOR SWITCH is provided at the rear of the equipment. It is used to select either a 120 V or a 220 V power supply. To set to either of the two sources, remove the stopper from the switch and turn the knob to the desired position.

It is important to use a 1 A fuse when set to the 220 V source, and a 2 A fuse when set to the 120 V.

**When installing the power cord, be sure to adhere to these rules:**

1. Be absolutely careful that the switch is set in the correct voltage position before attempting to turn on the transceiver. The equipment is set to 220 V before leaving the factory. Our warranty does not cover damage caused by excessive line voltage due to improper setting of the A-C POWER SELECTOR SWITCH.
2. Have POWER switch turned off, and STANDBY switch in REC position.
3. Be sure to discriminate AC and DC correctly, and be careful not to get "shocked" when connecting the cord to the power supply source, particularly when plugging into or unplugging from the AC outlet.

Each power cord has its one end terminated with a 4-P plug complete with a stopper. When inserting this end into the connector on the transceiver, be sure to press down the stopper with your finger and engage it into the latch on the transceiver side.

To pull the cord off the transceiver, push down the stopper to disengage it from the latch and then give a pull to the cord end.

### 2-4. ANTENNA CONNECTION

Efficient, enjoyable QSO presupposes the use of an antenna whose performance does in no way cut down the high performance built into this transceiver.

The ground-plane antenna is good for the majority of transceiver applications. This antenna should be set up at a height of 10 to 20 meters, and a coaxial cable should be used to connect it to the transceiver. For the cable, a low-loss cable is recommended.

Where greater communicating distances are involved; or if the two-way communication is to be maintained with a particular station, a high-gain directional antenna, such as a Yagi antenna, should be used.

A non-directional antenna should be used if the transceiver is to serve in a localized coverage involving mobile duty.

### 2-5. MICROPHONE

The microphone furnished with this transceiver is a 500-ohm impedance one designed specially for radio equipment of this class. Any other microphone may be used provided that its type and characteristic are suited to the TS-700. The optimum impedance of a microphone is anywhere between 500 and 600 ohms. Refer to Fig. 2 for the method of microphone connection. Fig. 3 illustrates the circuit of a press-to-talk (PTT) microphone.

### 2-6. SENDING KEY

The jack for connecting the sending key device is provided in the rear panel of the transceiver. Plugging the

cord into this jack defeats SSB, AM and FM modes and allows the transceiver to be operated only in CW mode.

### 2-7. EXTERNAL SPEAKER CONNECTION

An oval speaker is built in this transceiver, but speaker output is available not only from this but from an external speaker connected to the EXT. SP jack provided in the rear panel. To drive such a speaker from this jack, be sure to terminate the interconnecting cord with the plug fitting furnished as an accessory.

It is recommended that a speaker rated at 8 ohms of impedance and whose low and high ranges are sharply cut off (this is what is called a transceiver speaker) be used for this purpose. Plugging in an external speaker cord automatically cuts the internal speaker out of service.

Driving an external speaker from PHONES jack (front panel) is not recommendable: this jack is provided with a level-adjustment resistor when using headphone and is not fit to drive such a speaker.

When connecting an external speaker, be careful not to "short" the AF output circuit and try to minimize the length of the cord, which should preferably be of shielded type, so as to prevent radio-frequency energy from reaching the speaker through ground.

### 2-8. VOX CONNECTOR

It is essential that a 9-pin connector be connected to the VOX terminals located at the rear of the equipment. If otherwise, you cannot put the transmitter on the air.

### 2-9. MIC HOOK

Attach a microphone hook to the case following the instructions given in Fig. 1. The hook is furnished with the equipment.

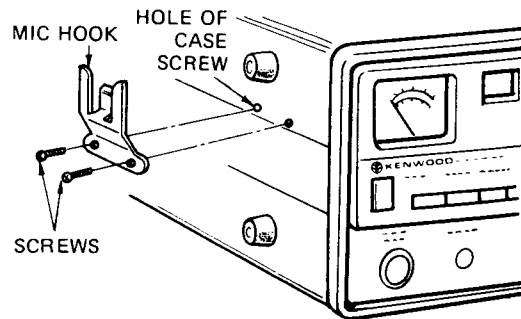
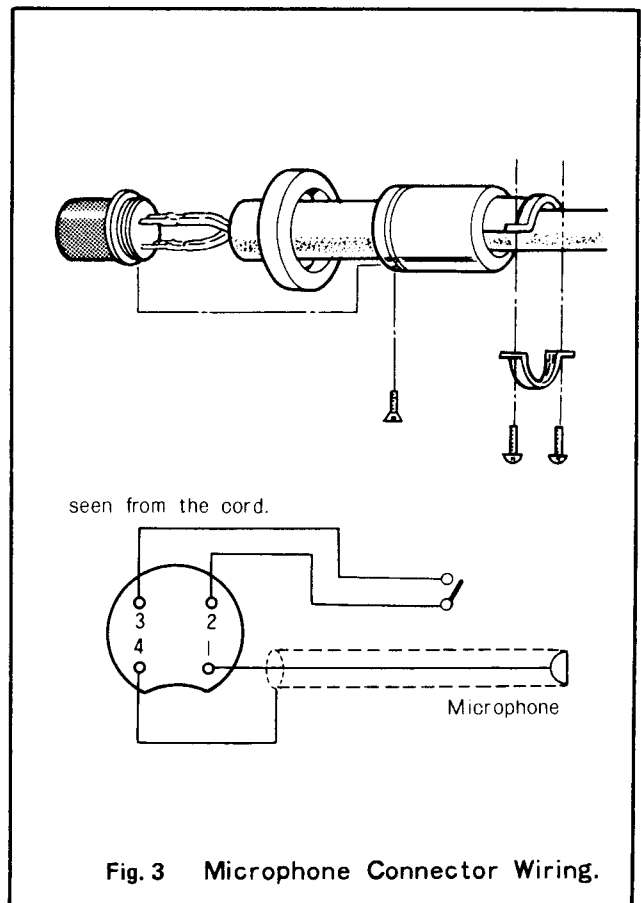
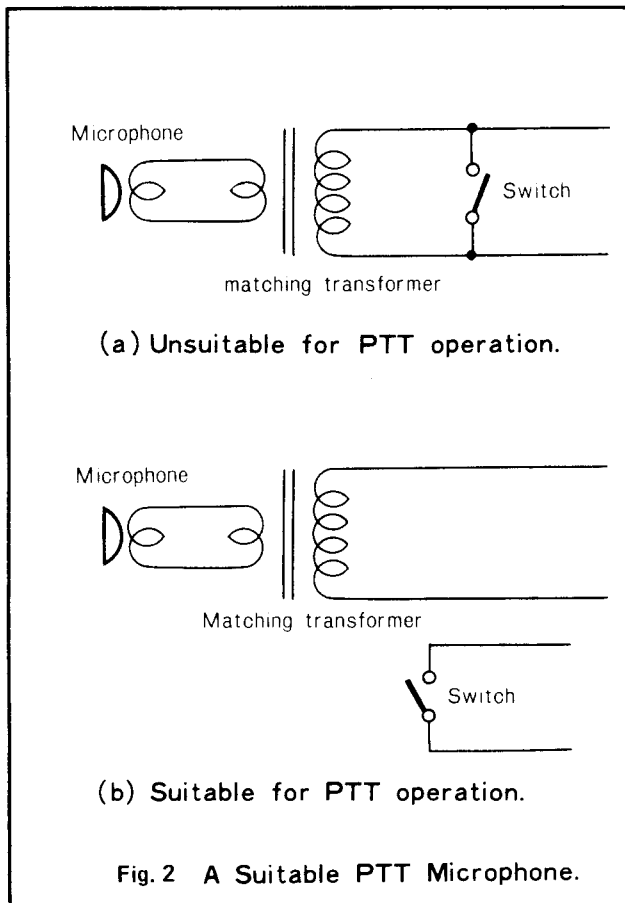
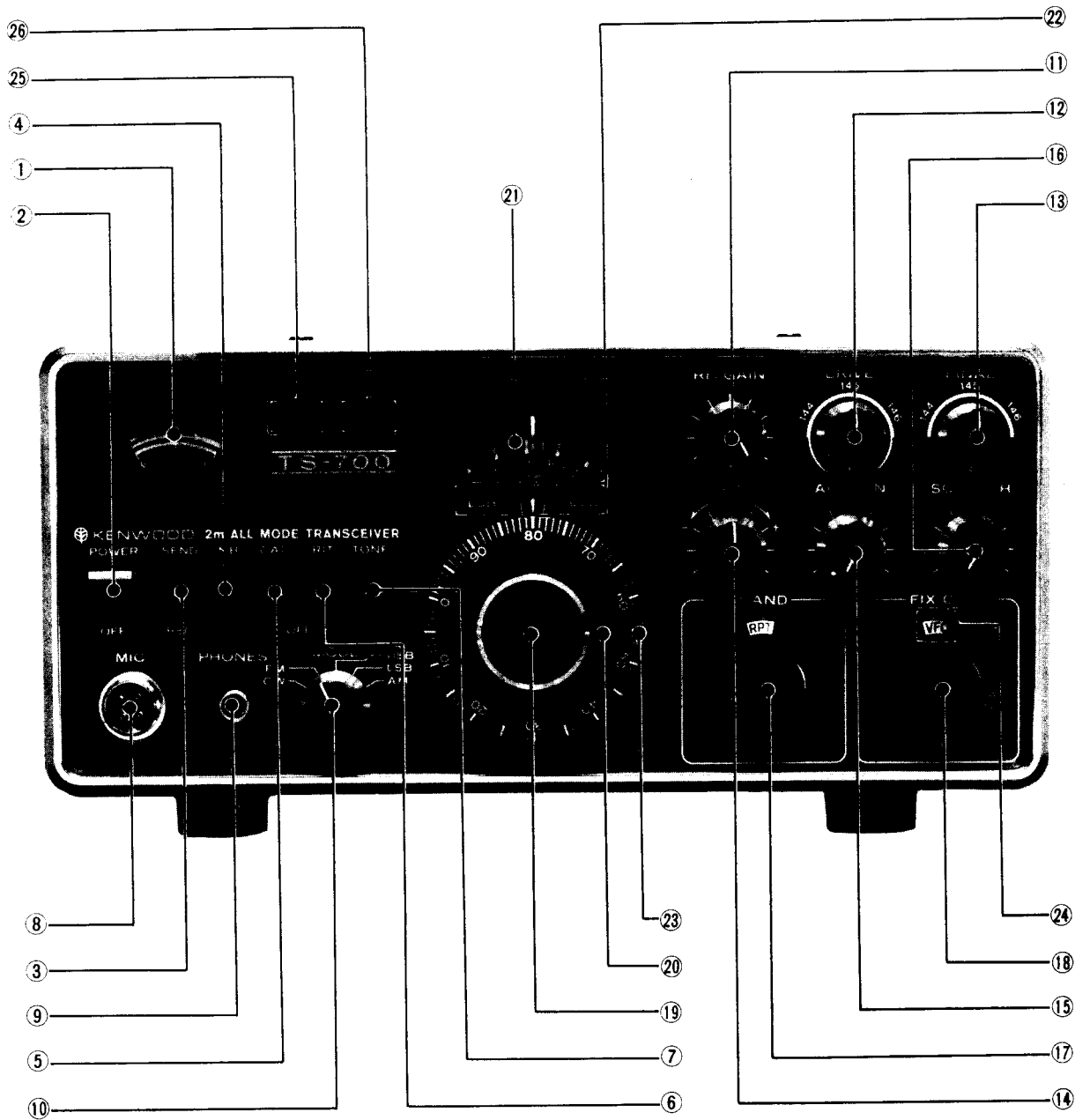

Fig. 1



## SECTION 3. OPERATING CONTROLS



- |                         |                           |                             |
|-------------------------|---------------------------|-----------------------------|
| 1. Meter                | 10. MODE Switch           | 19. Main Tuning Knob        |
| 2. Power Switch         | 11. RF GAIN Control       | 20. Coarse Tuning Knob      |
| 3. Stand-by Switch      | 12. DRIVE Control         | 21. Sub-dial                |
| 4. Noise Blanker Switch | 13. FINAL Control         | 22. Dial Pointer            |
| 5. CAL Switch           | 14. RIT Control           | 23. Main Dial Scale         |
| 6. RIT Switch           | 15. AF GAIN Control       | 24. FIXED CHANNEL Indicator |
| 7. TONE Switch          | 16. SQUELCH Control       | 25. ON-AIR Indicator        |
| 8. Microphone Connector | 17. BAND Switch           | 26. RIT Indicator           |
| 9. Headphone Jack       | 18. FIXED CHANNEL Control |                             |



### 3-1. Front Panel Controls

#### (1) METER

This meter has two functions. During reception, it serves as an "S" meter indicating the strength of received signal on a scale graduated from 1 to 9, 9 + 20 dB and 9 + 40 dB. During transmission, the meter indicates the strength of RF output signal.

#### (2) POWER SWITCH

The power to the transceiver is turned on by flipping the power switch to the up position, and turned off at the down position of the switch.

**NOTE:** *Pilot lamps will light up with some time lag upon a turning on of POWER switch. The lag is due to the AVR action on the lamp circuit, and should be no cause for alarm.*

#### (3) STANDBY SWITCH

This too is a two-position lever switch: top position is for transmission, bottom position is for reception. The transceiver in receiving state, with STANDBY switch in top position, automatically shifts to transmitting state when the microphone PTT switch is turned on. Do not leave the transceiver in transmitting state when its transmitting circuit is out of adjustment, or causes of trouble may develop in the transceiver.

REC . . . . Receiving, ready for electrical switching to transmitting state.

SEND . . . . Locking the transceiver in transmit mode.

#### (4) NOISE BLANKER SWITCH

For on-off control of the noise blanker circuit. Turning on this switch cuts in the blanker circuit to suppress pulse-type noises due to the ignition systems of nearby cars, for instance. A clean and clear audio output can be obtained even from a weak signal received, when this switch is on.

#### (5) CAL SWITCH

This switch allows the receive frequencies to be calibrated at intervals of 1 MHz when the transceiver is in receive mode. Flipping this switch to the up position activates the MARKER oscillator.

#### (6) RIT SWITCH

For on-off control of the RIT (Receiver Incremental Tuning) circuit. This circuit becomes activated when the RIT switch is flipped up, and, if the transceiver is in receive, the RIT allows the receive frequency to be adjusted more closely. The RIT circuit can be used in conjunction with VFO and fixed channels.

#### (7) TONE SWITCH

This switch is used to call in a repeater station. Holding the switch upward operates a tone oscillator at 1,750 Hz, and at the same time, a repeater call signal is automatically transmitted.

#### (8) MICROPHONE CONNECTOR

This connector is designed for 4-pin connection. Its

terminals are for microphone input and for PTT circuit.

#### (9) HEADPHONE JACK

This jack admits a standard 2-P plug. The impedance rating of the headphone to be used should be anywhere between 8 ohms and 16 ohms.

#### (10) MODE SWITCH

By means of this switch, the mode can be selected from the following five:

CW mode . . . . Morse-code telegraphic communications ( $A_1$ ).

FM mode . . . . Communications with FM waves ( $F_3$ ).

USB mode . . . . Communications with "upper side-band" waves. For operation in 144-MHz 2-meter band, international amateur practice calls for the use of USB ( $A_{3J}$ ).

LSB mode . . . . Communications with "lower side-band" waves ( $A_{3J}$ ).

AM mode . . . . Communications with AM waves ( $A_3$ ). Reception of the "LSB" or "USB" signal in AM mode results in unintelligible wow-like audio output.

#### (11) RF GAIN CONTROL

For adjusting the gain of the RF amplifier in the receiver section. With this control turned to extreme clockwise position, the gain is maximized, and vice versa. "S" meter indicates the gain set by this control. If the indicating hand of this meter is at "9", then radio waves of lower than "9" level will experience attenuation; this feature emphasizes the wanted signal and suppresses the unwanted signals to produce a clear output.

#### (12) DRIVE CONTROL

For tuning the RF driver and MIX input coil for best reception and the output circuit of the HET mixer for best transmission. This control adjusts the electronic tuning circuit designed for simultaneous tuning in transmit-receive operation.

#### (13) FINAL CONTROL

The antenna-side BPF is tuned by this control. It provides a very effective control in minimizing the spurious component during transmission and avoiding undesirable modulation by interfering signals during reception.

#### (14) RIT CONTROL

This control is used when the RIT circuit is ON. It adjusts the receive frequency without changing the transmit frequency. Here's how to use this control: index the pointer of this control to RIT "0" on the panel face—this will introduce coincidence between transmit frequency and receive frequency—and check the frequency of the other party; if the checked frequency is at variance with yours, shift the receive frequency (without regard to transmit frequency) by about  $\pm 2$  kHz to match it to that of the other party. The RIT circuit is operative even when VFO

or any of the fixed oscillator channels is in service.

#### (15) AF GAIN CONTROL

This control adjusts the gain of the receiving audio amplifier. Turning it clockwise increases the audio volume.

#### (16) SQUELCH CONTROL

The squelch circuit comes into action during FM mode of operation when this control is turned clockwise. Turn it to the position at which internally-induced noise disappears.

#### (17) BAND SWITCH

For selecting the frequency band at which the transceiver is to be operated. Two selective bands, 1 MHz wide, are provided for all amateur bands in the range from 144 MHz to 146 MHz.

Repeater communication is performed in the 145 to 146 frequency range for reception, and in the 144.4 to 145.4 range for putting the transmitter on the air.

#### (18) FIXED CHANNEL CONTROL

For selecting the channel from VFO and 11 fixed oscillator channels (or 22 channels for 2-band operation). The oscillating frequency of the crystal element in a fixed channel remains unchanged: for instance, the operating frequency of 144.48 MHz available in the 144-MHz band changes to 145.48 MHz when a shift is effected by switching to the 145-MHz band.

IN the RPT band, the receiving frequency is 145.48 MHz. The frequency for transmission is 144.88 MHz.

#### (19) MAIN TUNING KNOB (inner)

For setting the transceiver to the desired operating frequency. One rotation of this knob changes the frequency by 25 kHz.

#### (20) COARSE TUNING KNOB (outer)

Another name of this knob is a "fast-change" tuning knob. The gear ratio in the mechanical link between this knob and VFO is so small that you can quickly reach the position for the desired frequency. One rotation of this knob corresponds to a change of 100 kHz.

#### (21) SUB-SCALE

This scale is graduated from "0" up to "1000," covering a width of 1 MHz. Each graduated interval stands for 50 kHz.

The scale disc rotates in the same direction as the MAIN TUNING knob and COARSE TUNING knob at such ratios of rotation that the whole 0~1000 range is traversed when the MAIN knob is rotated 40 times or when the COARSE knob is rotated 10 times.

#### (22) DIAL POINTER

The pointer marks serve as the reference for reading the operating frequency for each mode of operation (USB, LSB, CW, FM or AM). Side marks are for sideband frequencies; center mark (▼) is for CW, FM and AM frequencies.

#### (23) MAIN DIAL SCALE

The circumference is divided into 100 equal parts, each part

or interval being 1 kHz in width. This scale is directly coupled to the COARSE TUNING knob, but a provision is included to enable this scale to be displaced by sliding with the COARSE TUNING knob held stationary for effecting a frequency calibration.

#### (24) FIXED CHANNEL INDICATOR

This lamp indicator comes on to tell that VFO or a fixed channel is in service. During fixed-channel operation, this indicator instantly tells whether optional crystal oscillators for fixed channels are mounted or not.

#### (25) ON-AIR INDICATOR

This lamp comes on when the STANDBY switch is in "SEND" position to tell that the transceiver is in transmitting condition. Even when the switch is in "REC" position, turning on the PTT switch causes this indicator to light up.

#### (26) RIT INDICATOR

This lamp remains on to indicate that RIT circuit is operating. To be borne in mind is the fact that, when this lamp is on, transmit frequency may differ from receive frequency.

### 3-2. Rear Panel Controls

#### (1) HEAT SINK

The heat generated by the final-stage transistor in the transmitter section is dissipated through this heat sink. Good ventilation must be maintained at all times while the transceiver is in operation.

#### (2) AC 1A FUSE HOLDER

The 1-amp fuse contained in this holder is located in the primary-side circuit of the AC power source. (AC 220V)

#### (3) VOX CONNECTOR

The terminals are for use with an external VOX circuit. When the VOX circuit is not in use, the 9-pin jumpered VOX connector provided with the TS-700 must be inserted in this socket for normal operation. If this caution is neglected, the stand-by relay will not operate, and you cannot put the transmitter on the air.

#### (4) POWER SUPPLY CONNECTOR

The furnished AC or DC power supply cable is to be tied into this connector. A stopper is provided on each side of the connector; after tying in the power supply cable, secure the connection by engaging these stoppers.

#### (5) RL-MAKE RELAY CONNECTOR

The relay operates automatically in response to the change of state of the transceiver. When the transceiver shifts to receive operation, the relay opens its contactor; as the transceiver shifts back to transmit operation, the relay closes its contactor to establish the ground connection.

#### (6) ALC INPUT JACK

For admitting an external ALC input voltage, as when a linear amplifier is used.

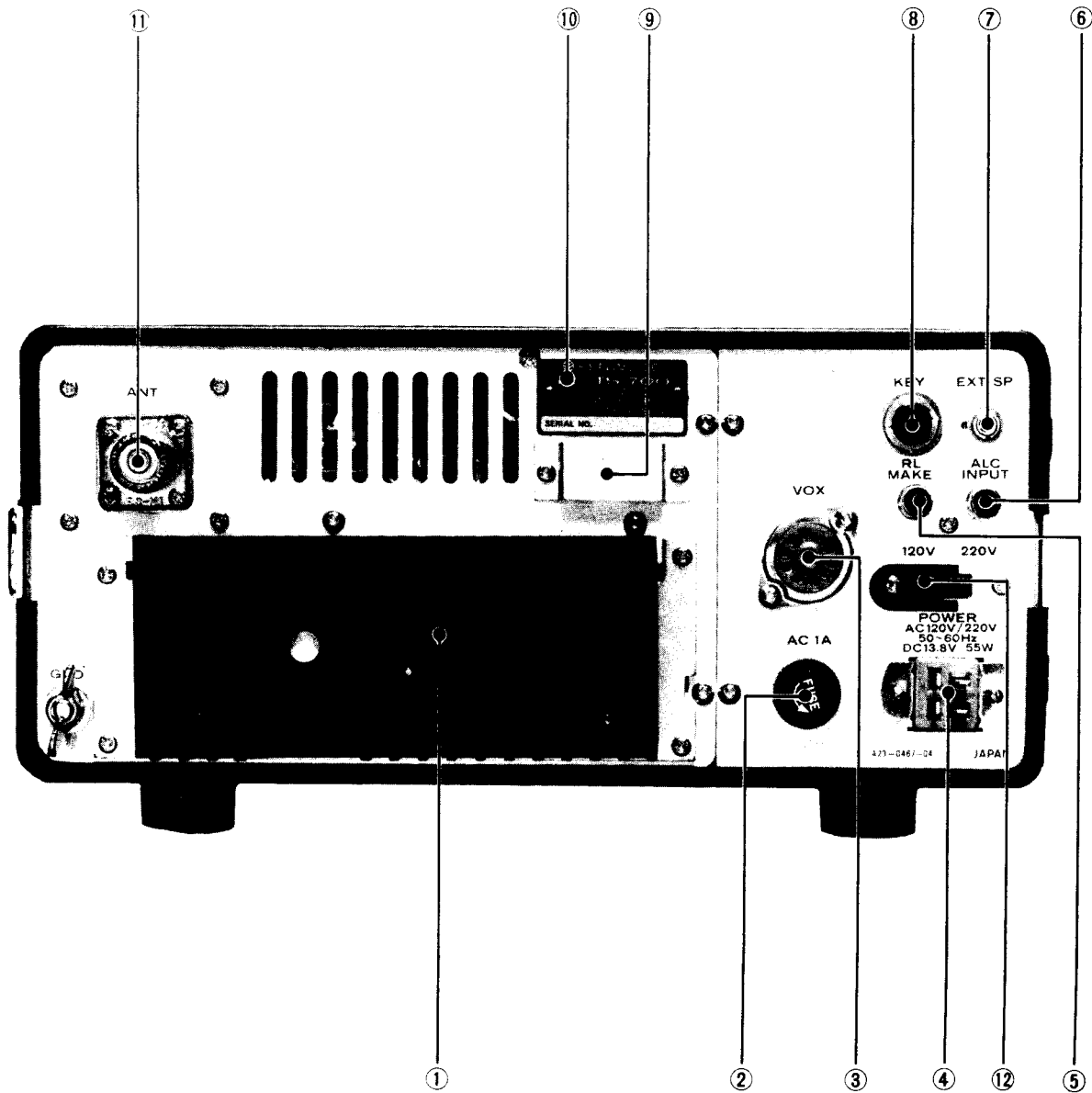

- |  |  |
|--|--|
| <ul style="list-style-type: none"> <li>1. Heat Sink</li> <li>2. AC 1A Fuse Holder</li> <li>3. VOX Connector</li> <li>4. Power Supply Connector</li> <li>5. RL-MAKE Relay Connector</li> <li>6. ALC Input Jack</li> </ul> | <ul style="list-style-type: none"> <li>7. EXT. Speaker Jack</li> <li>8. Key Jack</li> <li>9. Transistor Protective Cover</li> <li>10. Name Plate</li> <li>11. Antenna Connector</li> <li>12. AC Power Selector Switch</li> </ul> |
|--|--|

**(7) EXT. SPEAKER JACK**

An external speaker can be driven from this jack. For such a speaker, be sure to use an 8-ohm one.

**(8) KEY JACK**

This jack is used for operating the transceiver in CW mode. Connect an external telegraphic key device to this jack, with a 2-pin plug terminating the interconnecting cord.

**(9) TRANSISTOR PROTECTIVE COVER**

The transistors (on the inner side of the back panel) in the AVR circuit for 11-volt and 20-volt lines are protected by this cover. The cover doubles as the heat dissipator for these transistors.

**(10) NAME PLATE**

A Model TS-700 transceiver serial number is marked on this plate.

**(11) ANTENNA CONNECTOR**

The antenna circuit is designed for an antenna with 50-ohm impedance, to be hooked to this connector through a 50-ohm coaxial cable.

**(12) AC POWER SELECTOR SWITCH**

This slide switch switches the primary of the power transformer to select 120 or 220 V AC operation.

## SECTION 4. OPERATING INSTRUCTION

### 4-1. PREPARATION

It is assumed here that the transceiver is properly positioned and set up at the place of use, with the antenna, microphone and telegraphic key device connected to it.

Set the front-panel controls as indicated in Table 1:

**Table 1. Initial settings of control on front panel**

POWER switch	OFF
STANDBY switch	REC
NB switch	OFF
CAL switch	OFF
RIT switch	OFF
TONE switch	OFF
MODE switch	Set in the position of desired mode: CW, FM, USB, LSB or AM.
RF GAIN control	Extreme cw position
DRIVE control	Center
FINAL control	Center
RIT control	0
AF GAIN control	Extreme ccw position
SQUELCH control	Extreme ccw position
BAND switch	Desired band
FIX. CHANNEL control	VFO

### 4-2. RECEIVER TUNING

Turn on POWER switch. The pilot lamps for METER, SUB-SCALE, SUB-SCALE pointer, BAND switch and FIXED CHANNEL switch will all come on: the transceiver is now in energized state and ready for operation. Because of the all-solid-state design, the transceiver gets ready almost instantly when POWER switch is turned on.

Slowly twist AF GAIN control clockwise until you begin to hear the receiver background noise; set this control at the position where the signal is clear and loud enough and the background noise is weak enough for your purpose.

Rotate MAIN TUNING knob slowly to tune VFO for best signal reception. Adjust DRIVE control for maximized sensitivity: this control doubles as the pre-selector for receiving operation. Frequency markings on DRIVE control are to be referred to as your guide in securing the desired operating frequency.

Adjust FINAL control for maximized reception: this control is not as sharp as DRIVE control in tuning accuracy. Automatic gain control is "fast" for FM, AM and CW modes but "slow" for USB and LSB modes. RF GAIN control is to be normally left in extremely clockwise position; if the incoming radio signal is very strong, turn it back slightly for "throttling" effect. This effect is often needed when you are receiving SSB signal. Even with RF GAIN control set in a lower position, "S" meter will always

indicate signal strength correctly as long as the intensity of incoming signal is sufficiently high.

Your transceiver may happen to be located close to sources of such pulse-like or surging noises as those coming from motor-car ignition systems. In such a case, turn on NB switch for noise blanking.

The foregoing techniques are common to all modes of operation. Each mode, however, calls for special techniques of its own. Such special techniques will be discussed for each of the five modes.

#### CW mode

With RIT switch turned off, position MAIN DIAL in such a way that the incoming CW signal will beat at 900 Hz. Under this condition, you can "zero in" your operating frequency to the frequency of incoming CW signal.

Similarly, if the other party calls back with 900 Hz beat tone in response to your call signal, it means that the transceiver of the other party is in "zero in" status. Should the other party calls back with a beat tone off 900 Hz or should you want to communicate with a beat frequency of your choice, turn on RIT switch and adjust RIT control to obtain the desired beat.

#### FM mode

Set MAIN dial at the position for optimum reception. If the "S" meter indication happens to be wobbly as if it were affected by audio, reposition MAIN DIAL by turning it a little—say, several kHz of its scale—until the indication becomes steady to imply the absence of "fading." At this point, frequency coincidence is established between transmission and reception.

Since the IF band is wide in FM mode, some deviation may occur (to cause the "S" meter to give a wobbly indication in the manner mentioned above); such a deviation does not interfere with satisfactory reception and is permissible. In transmitting operation, however, the other party could be using a fixed channel. Because of this possibility, it is advisable that you "zero in" your frequency to that of the other party: this too is to be accomplished by properly setting MAIN DIAL in such a way that the "S" meter will give a steady indication.

If the "S" meter pointer continues to wobble or if a satisfactory audio output is not available, it is very likely that the other party is sending the message on SSB: you can easily check this by turning MODE switch to SSB position.

#### SSB mode

Of the single sideband mode, LSB is traditionally more often used than USB. As far as the operating technique is concerned, there is no difference between the two.

Once the transceiver is set in "zero in" status and if the frequency of the other party causes a deviation later, the RIT switch should be set to ON and the RIT control be adjusted for correct frequency.

With RIT switch turned on, the transmit and receive frequencies of your transceiver becomes subject to deviation. When calling on the other party, therefore, be sure to have RIT control set to "0" position or RIT switch turned off.

#### AM mode

Optimum reception of an AM signal is secured by tuning the transceiver in such a way as to maximize the deflection of the "S" meter pointer. Since the bandwidth of the receiver crystal filter is somewhat narrow because this filter is primarily for SSB reception, the sound output of the speaker may have its high-pitch components suppressed and hence lack clarity. This can be remedied by shifting the receive frequency a little by using RIT control: the same effect can be produced by means of MAIN DIAL but the use of MAIN DIAL for that purpose is not recommendable because, should you do so, you will not be able to "zero in" your transmit frequency to the frequency of the other party.

### 4-3. TRANSMITTER TUNING

Have a 50-ohm dummy load or antenna connected to the transceiver before starting to adjust the various controls. To make sure that the radio waves you emit during initial tuning will not interfere with other radio stations, use the dummy load, which is sized to dissipate about 20 watts of transmitter power.

The tuning procedure should be completed within the least time possible, after setting the front-panel control according to Table 2:

**Table 2. Initial settings of control on front panel**

POWER switch	OFF
STANDBY switch	REC
NB switch	OFF
CAL switch	OFF
RIT switch	OFF
TONE switch	OFF
MODE switch	CW
RF GAIN control	Extreme clockwise position
DRIVE control	144
FINAL control	144
RIT control	0
AF GAIN control	Set for proper volume on reception
SQUELCH control	Set for proper volume on reception
BAND switch	144
FIX. CHANNEL control	VFO

#### (1) CW mode

Turn BAND switch to "144 MHz" or "145 MHz," whichever is desired. After turning MODE switch to CW position, shift STANDBY switch from REC to SEND position just to make sure that the meter pointer deflects and ON-AIR lamp lights up, and then move back this switch to REC position.

You have selected the band, 144 MHz or 145 MHz, and MODE switch is set to CW mode. Under this condition, move STANDBY switch to SEND side, and rotate DRIVE control to make the pointer of the meter (now "RF" meter) deflect as far as possible. Next, adjust FINAL control to maximize the meter pointer deflection further. Repeat this manner of using the two controls, DRIVE and FINAL, a few times.

The foregoing procedure should be carried out rapidly, without unnecessarily long delay at each step. The telegraphic key device is assumed to be disconnected from the transceiver or, if it is connected, is assumed to be in "key-down" condition.

Having adjusted the transceiver as above, you are now ready to use the key for CW communication.

#### (2) Other modes

With the transceiver set in CW mode, connect the furnished microphone (or any other proper microphone) and, after adjusting the transmitter output to a maximum level, shift MODE switch to the desired mode position: FM, USB, LSB or AM.

Gain for the microphone can be adjusted by means of variable resistors MIC 1 (for FM) or MIC 2 (for SSB); these resistors become accessible when the top lid of the transceiver case is removed. The two resistors are factory-set to present no hindrance to ordinary QSO and should not be disturbed unless to do so is necessary for one reason or another. Turning the adjusting members on these resistors clockwise will raise the modulation factor.

### 4-4. RPT OPERATION

The RPT band is used when communication is to be established through a repeater station. With the BAND SELECT SWITCH in the RPT position, the TS-700 is tuned for reception in the 145 to 146 MHz range. In this frequency band, the transmitter operates in the 144.4 to 145.4 MHz range, with the dial scale indicating the exact frequency of reception.

If, for example, the frequency displayed on the dial scale is 125, the TS-700 is tuned to 145.125 MHz for reception, and to 144.525 MHz for transmission.

The built-in tone oscillator operates at 1,750 Hz when the TONE SWITCH is moved up, and at the same time, a repeater call signal is automatically transmitted.

Releasing the hand from the switch automatically stops

the oscillator. The frequencies covered by the RPT band for reception are the same as those used in the 145 MHz band. The transmitting frequencies are 600 kHz from those to which the TS-700 is tuned for reception.

#### 4-5. PUSH-TO-TALK OPERATION

The transceiver with its furnished microphone, or any other proper microphone equipped with a PTT switch, permits PTT (push-to-talk) operation, when its STANDBY switch is left in REC position.

#### 4-6. OPERATION WITH FIXED CHANNELS

The Model TS-700 has built-in oscillator circuits to be loaded with crystals for use in "fixed channel operation"—a mode of transceiver operation based on the use of crystal-controlled frequencies—which is of great advantage where the transceiver has to be operated frequently on certain frequencies. Examples of such a situation are: operation in frequently used FM mode, mobile operation in SSB, communications based on schedules of the other party, mobile operation in a vehicle; etc.

FIXED CHANNEL switch has a total of 12 positions, one of which is for "VFO", the other 11 positions being those for the 11 fixed oscillator circuits to be loaded with crystals (optional). When some or all of the circuits are loaded with crystals, the lamp will light up as the FIXED CHANNEL switch is turned to the position for any of the loaded channel circuits, each producing a fixed oscillator frequency of its own. You are to select the crystals for the desired frequencies, install the crystals, and indicate the frequency values in the 11 spaces provided on the CHANNEL switch.

When ordering for the crystals, how am I to specify the respective fixed channel frequencies? The method of obtaining the answer to this question will be described, starting with the definitions of some key terms:

- (1) Crystal oscillator frequency X (= fixed channel frequency) for FM, AM and CW (MHz)
- (2) Frequency (= operating frequency you desire) (MHz)
- (3) Heterodyne oscillator frequency (= 125.10 MHz) for the 144-MHz band
- (4) Transmitter IF frequency (10.70 MHz)

For fixed channel operation, each operating frequency is determined by (3) and (4) plus the crystal oscillator (fixed channel) frequency. Supposing that one of the operating frequencies you want is 144.48 MHz, you have to subtract (3) and (4) from 144.48 MHz; the remainder is the frequency which the crystal must produce. Let "X" stand for that frequency of the crystal:

$$\begin{aligned} \text{"X" MHz} &= 144.48 \text{ MHz} - (125.10 + 10.7) \text{ MHz} \\ &= 8.68 \text{ MHz.} \end{aligned}$$

In this manner, you can determine and specify the frequency for all of the 11 crystals to be purchased for loading the fixed oscillator circuits, in order to secure the repertory of desired operating frequencies for fixed channel operation. Conversely, a crystal with a predetermined frequency determines the operating frequency.

In the example above, we considered an operating frequency of 144.48 MHz for the 144 MHz band and found that an 8.68 MHz crystal is needed for loading a fixed oscillator circuit. If a shift is made from 144 MHz band to 145 MHz band, then the 8.68 MHz fixed oscillator circuit with that crystal will provide an operating frequency of 145.48 MHz.

It should be recalled that the 144 MHz band covers the frequency interval between 144 MHz and 145 MHz and that the 145 MHz band similarly covers the interval between 145 MHz and 146 MHz. Thus, each 1 MHz bandwidth can be filled with a total of 11 different operating frequencies resulting from 11 crystals and, since this transceiver provides two selective bands, we may say that it has a total of 22 fixed oscillator circuits.

**A word of caution is necessary here.** Consider two crystals known to give oscillating frequencies of 9.20 MHz and 8.20 MHz, respectively. These two crystals in fixed oscillator circuits will provide four operating frequencies, as follows:

$$\begin{aligned} \text{144 MHz band ... } &125.10 \text{ MHz} + 10.70 \text{ MHz} + 9.20 \text{ MHz} \\ &= 145 \text{ MHz} \\ &125.10 \text{ MHz} + 10.70 \text{ MHz} + 8.20 \text{ MHz} \\ &= 144 \text{ MHz} \\ \text{145 MHz band ... } &126.10 \text{ MHz} + 10.70 \text{ MHz} + 9.20 \text{ MHz} \\ &= 146 \text{ MHz} \\ &126.10 \text{ MHz} + 10.70 \text{ MHz} + 8.20 \text{ MHz} \\ &= 145 \text{ MHz} \end{aligned}$$

The operating frequencies of 144 MHz and 146 MHz are boundary frequencies and should be avoided. Should you use these two crystals, care must be taken to see that you do not select the 8.20 MHz fixed channel in 144 MHz band operation or the 9.20 MHz fixed channel in 145 MHz band operation.

The transmitter carrier oscillator gives an IF frequency of 10.7006 MHz in CW or AM mode. The fractional 600 Hz is too small to require, for practical purposes, a correction by means of the crystals to be put into the fixed oscillator circuits, and should be no cause for concern.

Here is an important rule to be adhered to when communicating in QSO, where your transceiver and that of the other party are both of the Model TS-700. The normal procedure would be that, in AM mode, you first "zero in" your frequency to that of the other party by adjusting your MAIN DIAL and send out the

signal, to which the other party will respond after, possibly, changing his frequency. If he should do so, the pointer of your "S" meter then would deflect down from the initial maximum level indication: this drop must not be interpreted as a sign of trouble. In such a case, you are expected to re-match your frequency to the new incoming frequency by using your RIT control but **never by re-adjusting your MAIN DIAL.**

One other tip for proper selection of the crystals is this: in SSB mode, your operating frequency will deviate by 1.5 kHz from the center frequency of the filter if the frequency of the crystal in a fixed oscillator circuit happens to be equal to that of FM. This deviation must be avoided. If you use the USB wave (which is dictated by the international amateur practice in the 2-meter band), select a crystal whose frequency is 1.5 kHz above that of FM. For instance, when you operate your transceiver at 144.150 MHz (assumed to be the desired frequency), then the frequency of the crystal you must use is:

$$8.3515 \text{ MHz} = 144.150 \text{ MHz} - (125.10 + 10.700 - 0.0015) \text{ MHz}$$

For LSB, however, the crystal frequency must be 1.5 kHz below that of FM.

#### 4-7. MOBILE OPERATION WITH EXTERNAL DC POWER SUPPLY

The TS-700 operates also with DC 13.8 volts supplied from an external DC source, and is therefore adapted to duty on a vehicle. Whether the TS-700 is used in a fixed station or in a mobile station, the techniques of operating it remain the same. A more enjoyable use is possible in mobile application provided that you yourself devise one or two provisions as to the place or manner of installation. If you are to operate your transceiver while driving the vehicle, then you should set up a proper mounting bracket right beside the driver's seat. You may locate the transceiver at the companion's seat but that would tax your attention more.

There are many 2-meter band mobile antennas available in the market. Most of them will do but a 1/4 wavelength ( $1/4 \lambda$ ) whip or ground-plane antenna a 5/8 wavelength ( $5/8 \lambda$ ) antenna is preferred.

A transceiver mounted on a vehicle should be used in fixed channel operation more often than not, for this manner of operation adds to safe driving. Have as many crystals secured as possible to take greater advantage of the fixed oscillator circuits built in the transceiver.

The TS-700 draws about 4 amperes maximum when it is working with full power. This much current is easily supplied by any automotive battery of about 35-AH capacity, but means an appreciably large additional energy

drain on such a battery. For this reason, battery maintenance must be effected with more intensive care to prevent it from "running down."

In SSB mode, you can cover a greater distance (for DX communication) and can keep in touch with more stations at distance than are possible with FM mode. However, controlling the transceiver in SSB mode requires some skill on your part and thus calls upon you to be more careful in driving the vehicle.

#### 4-8. RIT (Receiver Incremental Tuning)

The RIT feature enables you to shift the receive frequency by about  $\pm 2$  kHz without changing the transmit frequency, adjusting the receive frequency to the deviated frequency of the other party.

Here's how to use it: Turn on RIT switch, which will be followed by the coming on of the RIT pilot lamp; and tune your receive frequency to that of the other party by adjusting your RIT control.

A transceiver tuned this way (with receive frequency deviated by  $\pm 2$  to 3 kHz from transmit frequency) is off the TRANSCIVE frequency (one and the same frequency for both transmission and reception). To call out the other party during two-way communication when your transceiver is tuned as above, you must turn off RIT switch. Remember, RIT is effective also for fixed channel operation.

As to the detailed method of using RIT for each mode, refer to the information given in 4-2.

#### 4-9. READING THE FREQUENCIES (Fig. 4)

Operating frequencies can be read on the dials. The dial mechanism comprises the main dial, sub-dial, dial pointer, main tuning knob and coarse tuning knob. An approximate value of the frequency can be read on SUB-DIAL. Readings accurate to 1 kHz are to be taken on MAIN DIAL.

When you have your transceiver in SSB mode tuned accurately to the LSB signal coming in, perfectly demodulating this signal, read the frequency on MAIN DIAL as indicated by the LSB index line on DIAL POINTER. In the case of USB, the USB index line shows the frequency. See Fig. 4.

In the case of CW mode, vary the beat frequency by turning MAIN TUNING knob from higher side to lower side while receiving the desired signal from the other party; reduce the beat to zero by so turning the knob; and then rotate the knob upward to obtain a beat frequency of about 900 Hz. Under this condition, read the frequency on MAIN DIAL by referring to the triangle mark ( $\blacktriangledown$ ). Speaking generally, a beat frequency is present close to and



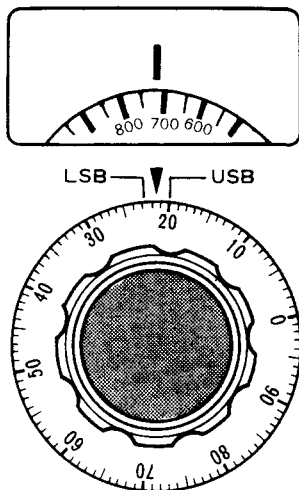

The frequency of USB in this illustration is 720 kHz. SUB-DIAL shows 700, MAIN DIAL shows 20.

$$\text{USB frequency} = 700 + 20 = 720 \text{ kHz}$$

This reading is to be added to the basic frequency selected by BAND switch. If BAND switch setting is "144 MHz," and if MODE switch is in "USB," then the operating frequency in this illustrated example is:

$$144.720 \text{ MHz} = \text{(operating frequency)} \\ 144.00 \text{ MHz} + 720 \text{ kHz}$$

Fig. 4

on both sides of the zero-beat point: one is a strong main beat and the other is a weak residual beat. Be sure to go by the main beat in your tuning operation.

In the above method, you are assumed to be able to discern a 900 Hz tone. The residual beat can be easily noted, because tuning to the neighborhood of 900 Hz on residual beat will result in little or no pointer deflection in your "S" meter.

When operating the transceiver on VFO, you read SUB-DIAL and MAIN DIAL and add the two readings to determine the operating frequency. This practice may sound rather difficult, but actually little or no training is necessary to do so. After a little experience, you will be able, almost intuitively, to find out the operating frequency.

*The knob on SUB-DIAL comes to a stop outside of the 0~1000 graduated range of the scale. After you reach this stop position, try not to rotate the knob any further, or you may break the gear.*

#### 4-10. FREQUENCY CALIBRATION (Fig. 5)

"To calibrate" is to determine, usually by comparison to a standard, the locations at which scale graduations should be placed to correspond to a series of values of the quantity. In the present case, the quantity is "frequency" and the standard (reference) is the 1 MHz marker signal available from the marker unit built in the transceiver.

"Frequency calibration" here means a process of ascertaining whether a scale is in accurate correspondence to frequency values or not. It also involves steps necessary for establishing the correspondence by adjustment.

##### Frequency calibration for USB

The marker signal is available at 1 MHz intervals. To

ascertain the accuracy of the scale for USB, zero-beat a marker signal at the "0" or "1000" position of MAIN DIAL. This "zero-beat" is to be accomplished by rotating the knob clockwise until the beat tone is changed from high to low pitch and finally disappears. Hold the knob at this position, and displace MAIN DIAL to bring its "0" graduation mark to the USB indicating line on DIAL POINTER.

The MAIN DIAL scale and its knob are held together by means of a spring and normally move together, but one can be displaced relative to the other by overcoming the friction due to the spring force.

##### Frequency calibration for LSB

The method for LSB is similar to the above method for USB, the difference being that the knob is to be rotated counterclockwise for "zero-beat". Match the "0" mark on MAIN DIAL to the LSB indicating line on DIAL POINTER.

Calibrating the scale for USB automatically calibrates it for LSB, and vice versa.

##### Frequency calibration for CW

The transmit frequency for this mode is about 900 Hz below that for the calibrated position indicated in Fig. (b) for LSB. Calibrate the scale by the foregoing method for USB, bringing the "0" mark on MAIN DIAL into register with the triangle mark (▼) on DIAL POINTER.

##### Frequency calibration for FM and AM

Beating by the marker signal in the manner mentioned above does not occur in this calibration. The reference is the "S" meter indication. Find the knob position at which the pointer of the "S" meter exhibits a maximum deflection: that position means that you have the transceiver correctly tuned to the carrier frequency. Then set the dial, as in the case of CW, with its "0" mark indexed to the triangle mark (▼) on DIAL POINTER.

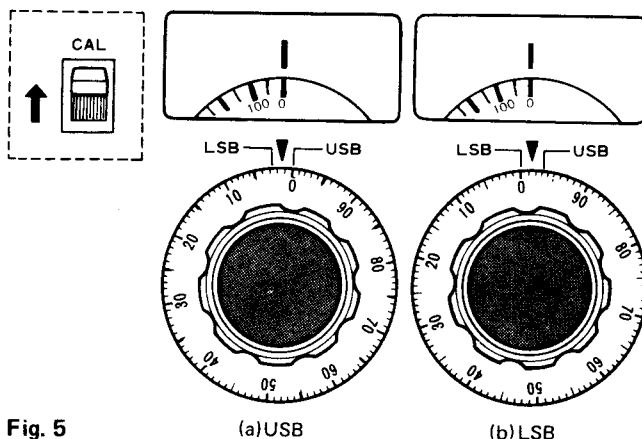

Fig. 5

(a)USB

(b)LSB

### "S" meter indication for FM

It will be helpful to you in making better use of your TS-700 transceiver to know the reason why the "S" meter is to be referred to while the marker frequency does not take part. Here is the reason:

When you are on FM, the IF circuit for SSB comes into the "S" meter circuit. Under this condition, the "S" meter deflects its pointer in such a logarithmic proportion to the incoming FM wave that, even with the strongest possible input, the meter pointer will have a sufficient leeway in its deflecting travel along the meter scale. Moreover, the "S" meter circuit is designed to exhibit no difference in indication between different modes.

With the transceiver operating on its VFO, the variation of meter indication is greater or smaller according

as the deviation from the FM center frequency is greater or smaller. Without deviation, that is, at the center frequency, meter indication will be steady, with the pointer nearly at standstill.

This characteristic of the "S" meter is to be taken advantage of in securing a frequency match on FM: you may take the "S" meter as if it were an FM zero-center meter. This manner of frequency matching relies much on the intensity of the signal being received; the intensity in turn has a great deal to do with the type of station from which the signal is coming—FIXED station or MOBILE station. Thus, frequency matching according to this method is easier to achieve if the incoming signal is high in intensity as well as frequency stability.

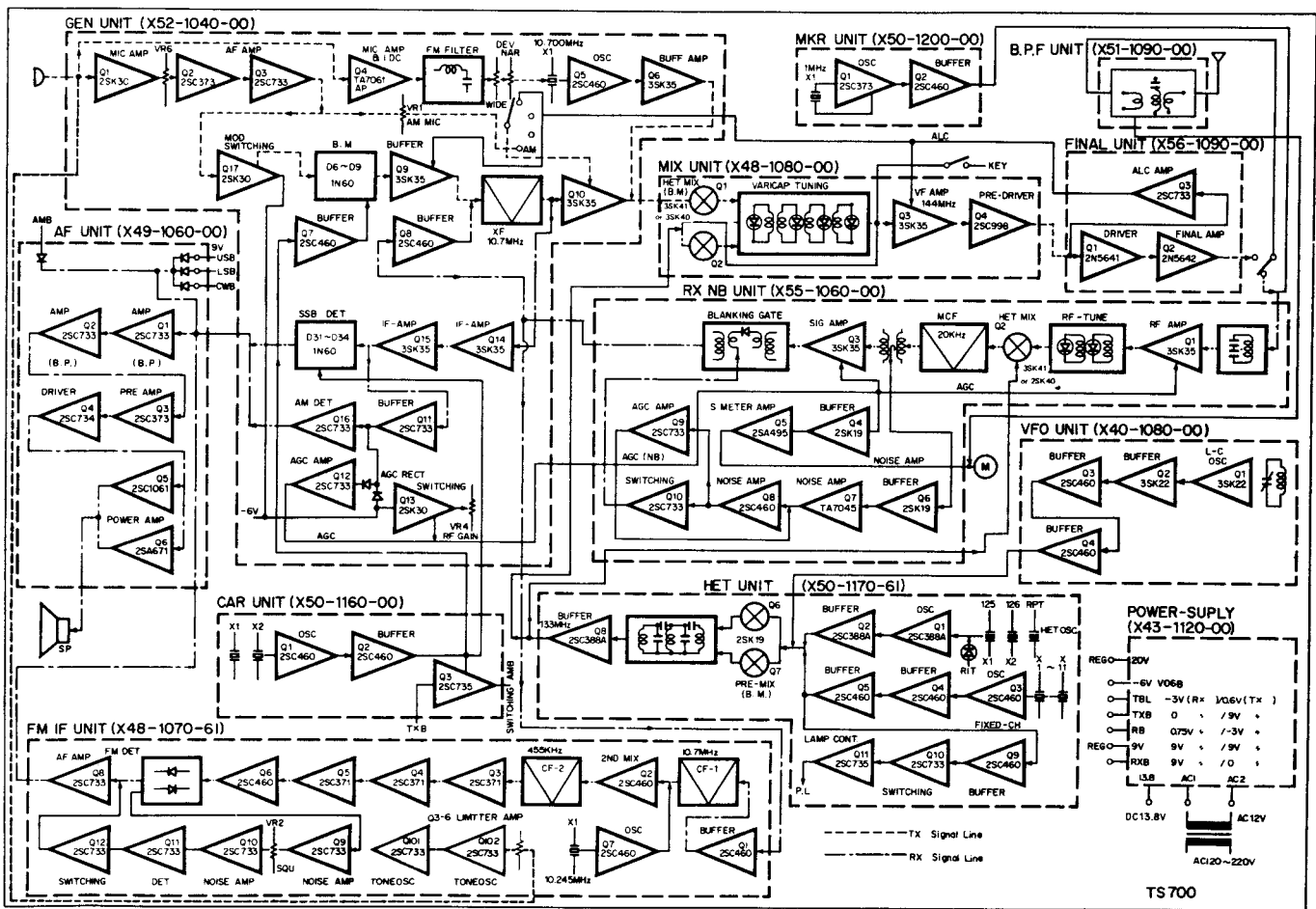

Fig. 6 TS-700 Block Diagram

# SECTION 5. CIRCUIT DESCRIPTION

## 5-1. Block Diagram

The circuitry of the Model TS-700 will be described in reference to the block diagram of Fig. 6. Solid-state parts used in this model are: 66 transistors, 20 FET's, 3 IC's and 106 diodes. Circuits are divided into utilized groups; all units, with the exception of band-pass filters (BPF's), are wired and built on printed-circuit boards.

The receiver section operates as a single super-heterodyne receiver in SSB mode and a double super-heterodyne receiver in FM mode. The transmitter section is more versatile; it is a single conversion type and operates as a filter type unit in SSB mode, a unit with direct modulator using a variable reactance frequency shift element in FM mode, a unit of low power modulation system in AM, and as a unit of block bias keying system in CW mode.

### Crystal oscillator frequencies

Carrier unit	USB	10.6985 MHz
	LSB	10.7015 MHz
	AM, CW	10.7006 MHz
Generator unit	FM	10.700 MHz
HET unit	144	125.100 MHz
	145	126.100 MHz
	RPT (R)	126.100 MHz
	RPT (T)	125.500 MHz

## 5-2. Unitized Circuits

### 1. CARRIER UNIT (X50-1160-00)

This unit produces a carrier frequency for the generator unit during transmission but acts as a BFO for ring detection during reception. It is a two-transistor circuit with oscillator crystals and diodes. The diodes are for selecting the USB, LSB or CW crystal, depending on the mode of operation.

### 2. GENERATOR UNIT (X52-1040-00)

The single-side-band (SSB) signal for transmission originates in this unit. Major components are an FET microphone amplifier, a two-transistor audio-frequency (AF) amplifier, a ring modulator composed of 4 diodes, and a buffer. Other devices are: a low power modulator circuit for AM, a variable reactance frequency shift modulator for FM, a ring detector for SSB reception, an IF circuit for SSB, AM and CW, and an AM signal detector.

During SSB operation, this unit generates a double-side-band (DSB) signals; this signal is injected into the crystal filter and comes out as an SSB signal. During CW operation, the ring modulator is forced into unbalanced condition by biasing with a DC voltage and, in the unbalanced condition, produces the carrier.

### 3. FM IF UNIT (X48-1070-61)

During reception, the input signal to this unit comes from the RX-NB unit. The signal passes through the 10.7 MHz ceramic filter and then is mixed with 10.245 MHz before passing through the 455 kHz ceramic filter, whose 455 kHz output undergoes FM detection in the limiter amplifier circuit. The detected output of the amplifier divides into two paths, one to the squelch circuit and the other to the gate circuit. The output of the squelch circuit enters the same gate circuit.

Thus, generation of intermediate frequency and squelching action are the two main functions of this unit for FM operation.

The TS-700 is equipped with a RPT tone oscillator which produces a low-frequency beat tone at 1,750 Hz.

### 4. MIX UNIT (X48-1080-00)

This unit comprises a heterodyne mixer, voltage and power amplifiers for the transmitter section. The output of the generator unit enters this unit to get converted into a 144 MHz signal by balanced mixing. This signal is then boosted to a higher voltage level through the variable-capacitance tuning circuit, and becomes subsequently power-amplified by the pre-driver circuit.

Block bias keying is effected by the balanced mixer and voltage amplifying FET for CW operation.

### 5. FINAL UNIT (X56-1140-00)

This is a 10-watt power amplification unit consisting of the driver and final amplifier stages with a built-in ALC circuit. The final stage is built compact, with its parts and mechanism mounted neatly on the chassis. Heat sinks for cooling are integral with the parts they cool.

### 6. BPF UNIT (X51-1090-00)

The two functions of this unit are "antenna coupling" and "spurious signal removal." It couples the transmitter and receiver to the antenna, and removes the spurious during transmission. The RF output level is detected in this unit.

### 7. MARKER UNIT (X50-1200-00)

The marker unit contains a built-in 1 MHz crystal oscillator, by which it generates the 1 MHz marker signal for calibration use.

### 8. RX-NB UNIT (X55-1060-00)

This unit is the RF part of the receiver section, and includes a noise blanker circuit for controlling a gate located in the signal path leading to the IF unit. The received signal entering this unit from the antenna first undergoes RF amplification, heterodyne mixing, and filtering through a crystal filter before it is passed through the gate (in open state) to the IF unit. The noise blanker is cut into service by turning on its switch (NB) on the panel and, when cut in, opens and closes the gate according to the level of the noise component of the incoming signal. The noise is discriminated by transistors on the basis of

## SECTION 6. ALIGNMENT

amplitude and frequency. Thus, a clean information signal goes to the IF unit.

Pulse noises (coming from ignition coils of cars) and others which are distinctly at variance with normal signals such as SSB in terms of frequency and amplitude are accurately detected and removed. Not to be confused with such noises are those resembling the normal signals: for example, noise signals due to corona discharges or high-frequency welders near by or to high-power oscillations (whose frequencies are outside but close to the IF band) in adjacent apparatus are beyond the capability of the noise blanker circuit. The transceiver should not be operated in the vicinity of these noise sources.

### 9. HET UNIT (X50-1170-61)

The 133 MHz band heterodyne frequencies are available from this unit. The output frequency is produced by mixing its 125 MHz with the 8 MHz input from the VFO unit or with the frequency available from any of the crystal-oscillator fixed channels. The mixing circuit is of balanced type. A band-pass-filter (BPF) circuit follows the mixer to prevent unwanted frequencies from leaking out of this unit.

### 10. VFO UNIT

A perfectly shielded unit, the VFO (variable frequency oscillator) unit consists of 2 FET's, 2 transistors and 2 diodes. Extremely stable VFO, equivalent to those of the TS-900, are secured in this unit. Its adjustments are highly delicate—too delicate for a person not skilled to attempt any re-adjustment.

**For this reason, the user is advised not to disturb the setting of this unit: the warranty on this Model TS-700 is conditioned on the original setting.**

### 11. AF UNIT (X49-1060-00)

This audio amplifier unit drives the speaker. The received signal, demodulated, flows through 2 stages of band-pass amplification, 2 stages of AF amplification and 1 stage of complementary amplification. The load impedance is 8 ohms.

### 12. POWER SUPPLY UNIT (X43-1120-00)

An AC bridge rectifier is included in this power supply unit to make it meet both AC and DC needs. The DC 20-volt supply to the FINAL and AF units is produced by means of a voltage multiplier circuit working with a DC 13.8-volt input. The regulated 9-volt supply is made available by an IC multiplier circuit from the DC 13.8-volts. The other voltage needs are met by branching off from the 20-volt and 9-volt supply circuits.

## 6-1. FREQUENCY ADJUSTMENT

Since the Model TS-700 transceiver is normally supplied with its 11 fixed oscillator circuits ready to be loaded with optional crystals by the user, the method of setting the trimmer on each circuit will be described on the assumption that the user will have obtained the oscillator crystals and installed them in these circuits for making more operating frequencies available to suit his needs:

**NOTE:** *A frequency counter, capable of counting frequencies up to 10 MHz, must be used to adjust the oscillator frequency of each circuit.*

- (1) Remove the two screws securing the top face of the case. Pull up the two grommets and open the top lid.
- (2) Connect the frequency counter to the point TP2 in the HET unit (X50-1170-61).
- (3) Adjust the trimmers (numbered 1 through 11) to produce the desired oscillator frequency as read on the frequencies determine the frequencies to be generated by the respective crystal oscillators.

Be sure to correctly identify the trimmer for each crystal-mounting socket. There are a total of 11 sockets. As to the method of operating the transceiver in fixed channel operation, refer to the detailed information given in 4-6., p. 15.

"f<sub>o</sub>" . . . crystal oscillator frequency (MHz) for FM, AM and CW

"f<sub>USB</sub>" . . . crystal oscillator frequency (MHz) for USB

"f<sub>LSB</sub>" . . . crystal oscillator frequency (MHz) for LSB

"X" . . . desired operating frequency (MHz)

For each f the two bands (144 MHz and 145 MHz), the crystal to be installed must be such as to produce the crystal oscillator frequency determined by the following formula for a desired operating frequency:

Band 1 . . . f<sub>o</sub> = X - (125.10 + 10.70) MHz

Band 2 . . . f<sub>o</sub> = X - (126.10 + 10.70) MHz

Band 1 . . . f<sub>USB</sub> = X - (125.10 + 10.700 - 0.0015) MHz

Band 2 . . . f<sub>USB</sub> = X - (126.10 + 10.700 - 0.0015) MHz

Band 1 . . . f<sub>LSB</sub> = X - (125.10 + 10.700 + 0.0015) MHz

Band 2 . . . f<sub>LSB</sub> = X - (126.10 + 10.700 + 0.0015) MHz

**NOTE:** The frequencies covered by the RPT band are same as those covered by the BAND 2 when the receiving frequencies are taken as the reference.

## SECTION 7. TROUBLESHOOTING

SYMPTOM	POSSIBLE CAUSES	REMEDY
Turning on POWER switch will not light up pilot lamp.	<ol style="list-style-type: none"> <li>1. AC power cord is not fully inserted into the connection.</li> <li>2. Power cord is not plugged fully into the supply socket.</li> <li>3. The fuse is blown off.</li> </ol>	<ol style="list-style-type: none"> <li>1. Push in the plug end of the cord all the way into the connector.</li> <li>2. Plug in the cord fully.</li> <li>3. Replace. (If the new fuse fails, it means the power supply circuit is in defective condition and needs repair.)</li> </ol>
Antenna is properly installed but the transceiver will not receive the signal.	<ol style="list-style-type: none"> <li>1. PTT switch on the microphone is in "talk" position.</li> <li>2. FIX. CHANNEL switch is in the position for a dead channel.</li> </ol>	<ol style="list-style-type: none"> <li>1. Turn PTT switch to "receive" position.</li> <li>2. Rotate the switch to VFO position or to a channel position for which the light comes on:</li> </ol>
No background noise from the speaker in FM mode.	<ol style="list-style-type: none"> <li>1. Squelch circuit is in service.</li> </ol>	<ol style="list-style-type: none"> <li>1. Rotate SQUELCH control to extreme ccw position.</li> </ol>
Transceiver is connected to antenna, but no sound is heard in the speaker while "S" meter pointer remains swung to the end of scale.	<ol style="list-style-type: none"> <li>1. RF GAIN control is set too low.</li> </ol>	<ol style="list-style-type: none"> <li>1. Rotate RF GAIN control clockwise all the way.</li> </ol>
Even in the absence of signal, "S" meter pointer remains deflected.	<ol style="list-style-type: none"> <li>1. RF GAIN control is set too low.</li> </ol>	<ol style="list-style-type: none"> <li>1. Rotate RF GAIN control clockwise all the way. (If this does not deflect the meter pointer back, the circuit is in trouble.)</li> </ol>
SSB signal is being received but speaker output remains unintelligible.	<ol style="list-style-type: none"> <li>1. Transceiver is set for a wrong sideband.</li> </ol>	<ol style="list-style-type: none"> <li>1. Shift MODE switch to USB or to LSB, depending on its current SSB position.</li> </ol>
RIT control is ineffective in fine tuning.	<ol style="list-style-type: none"> <li>1. With RIT switch in "on" position, RIT control is off "0" position.</li> </ol>	<ol style="list-style-type: none"> <li>1. Repair, or turn the switch to "on" position.</li> </ol>
There is a frequency lag between transmission and reception.	<ol style="list-style-type: none"> <li>1. Internal circuit of RIT switch is open, or this switch is in "off" position.</li> </ol>	<ol style="list-style-type: none"> <li>1. Turn off RIT switch, or move RIT control to "0" position.</li> </ol>
Noise blanker circuit is not fully effective in suppressing noise.	<ol style="list-style-type: none"> <li>1. A powerful signal, whose frequency is close to the operating frequency of the transceiver, is interfering.</li> <li>2. Some interfering noise similar to an SSB signal in waveform is coming in from a nearby source (such as high-frequency welder or corona discharging device).</li> </ol>	
Transceiver refuses to transmit.	<ol style="list-style-type: none"> <li>1. Absence of 9-pin MT plug in VOX connector.</li> </ol>	<ol style="list-style-type: none"> <li>1. Fit the MT plug to the connector.</li> </ol>
No output in SSB mode.	<ol style="list-style-type: none"> <li>1. Microphone plug is mis-connected or is not fully inserted into the jack.</li> <li>2. SSB mic volume (MIC2) is set too low.</li> </ol>	<ol style="list-style-type: none"> <li>1. Correct the connection according to the diagram, or push it in fully into the jack.</li> <li>2. Raise the setting by rotating the volume clockwise. (MIC 2 is within the transceiver.)</li> </ol>
Too small a modulation factor in FM mode.	<ol style="list-style-type: none"> <li>1. MIC1 is set too low.</li> </ol>	<ol style="list-style-type: none"> <li>1. Raise the setting by rotating it clockwise.</li> </ol>

# TOP & BOTTOM VIEW OF THE TS-700

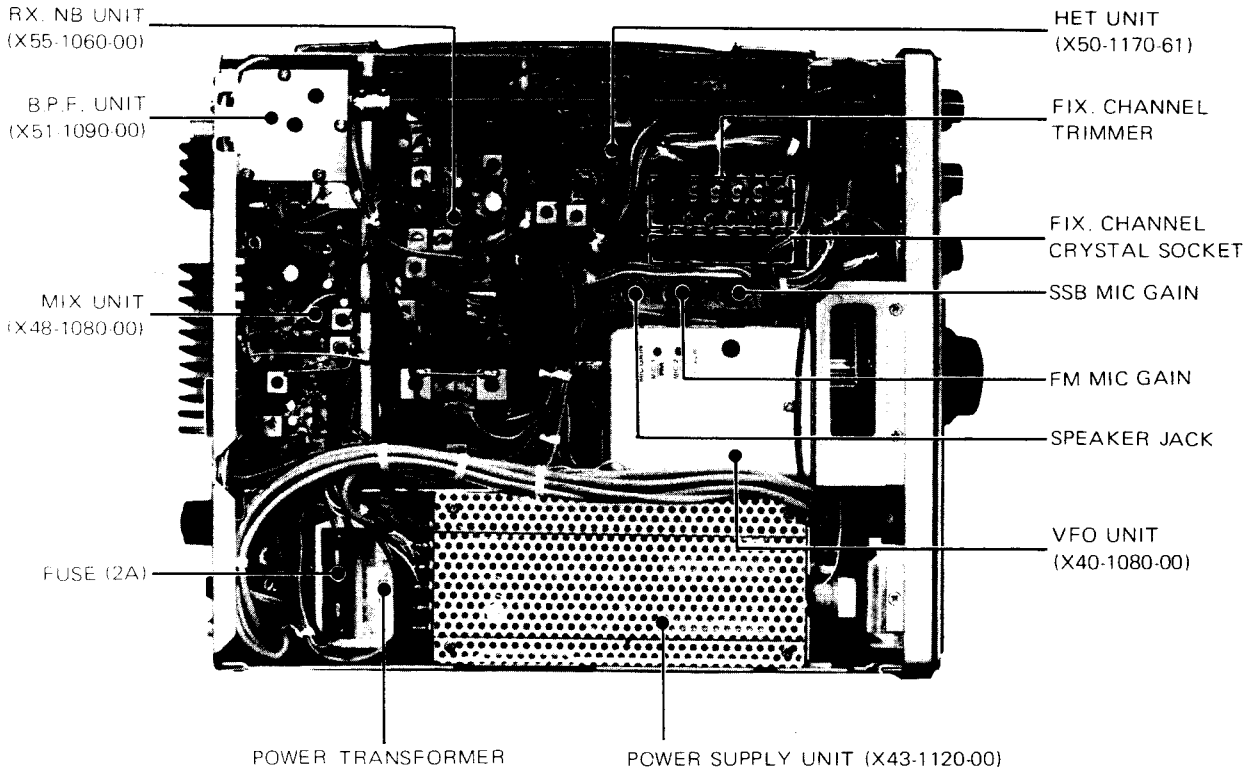

FM IF UNIT (X48-1070-61)

CAR. UNIT (X50-1160-00)

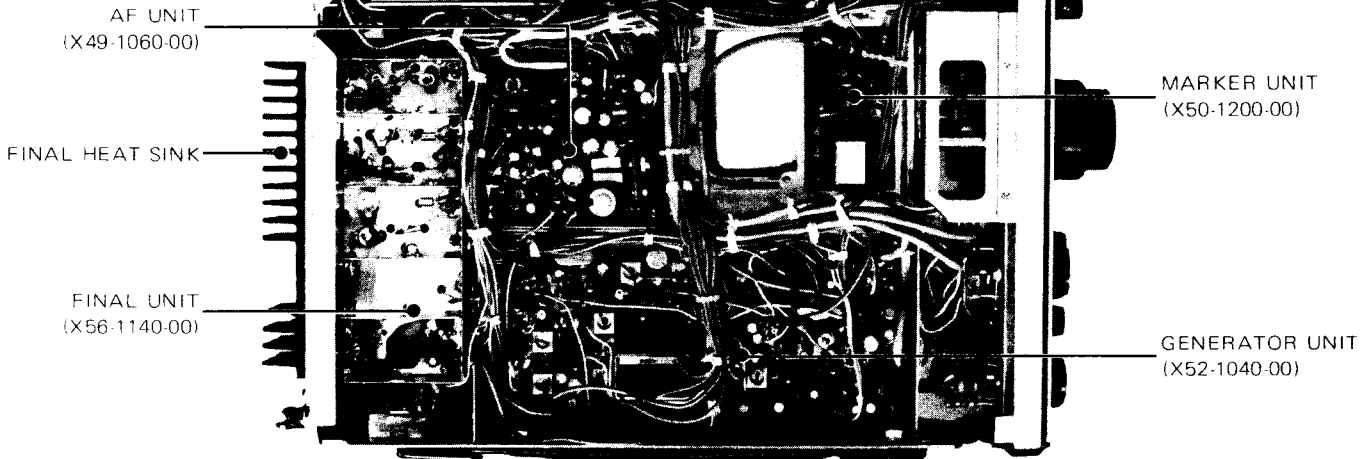

# TS-700 SCHEMATIC

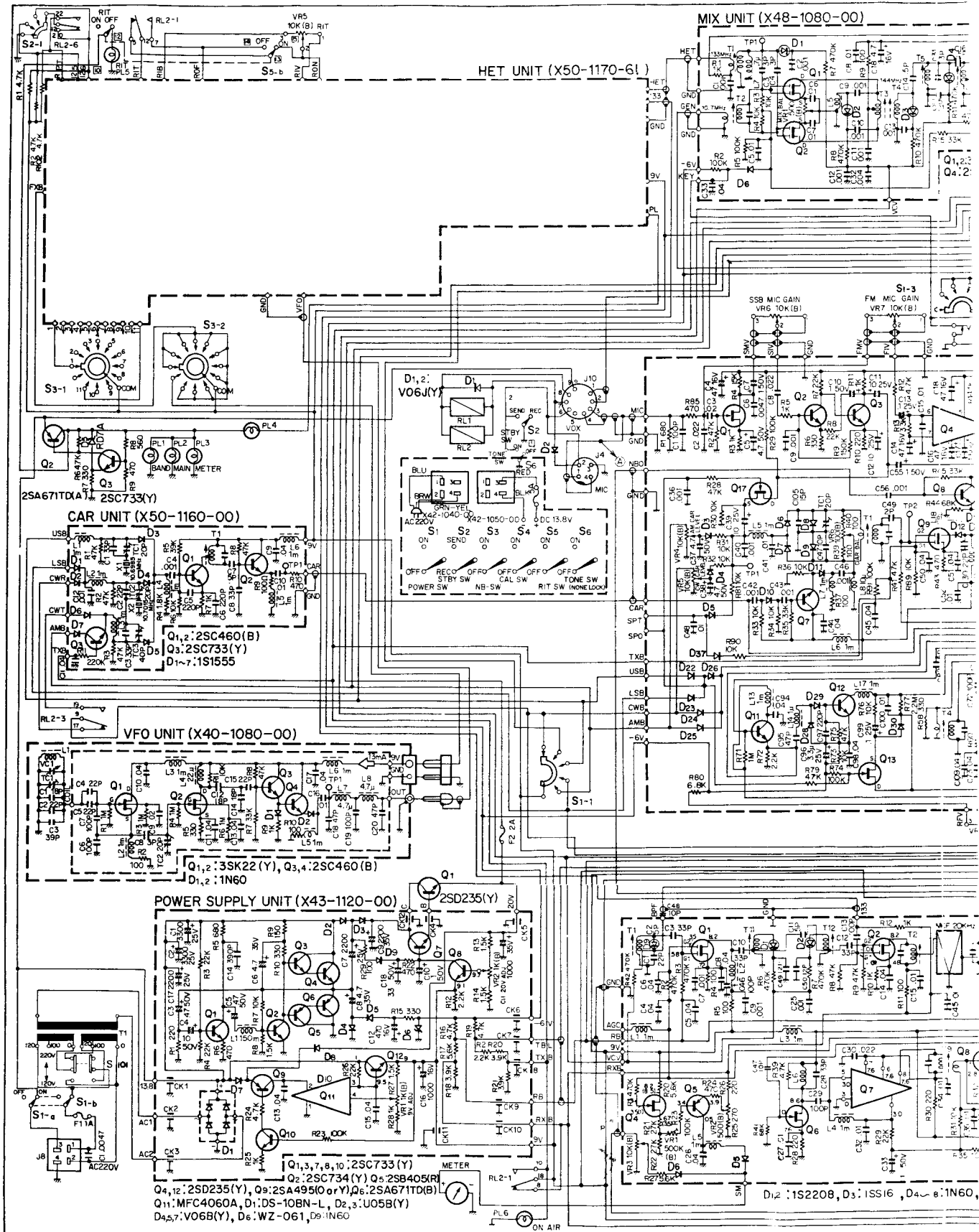

# TS-700 SCHEMATIC DIAGRAM

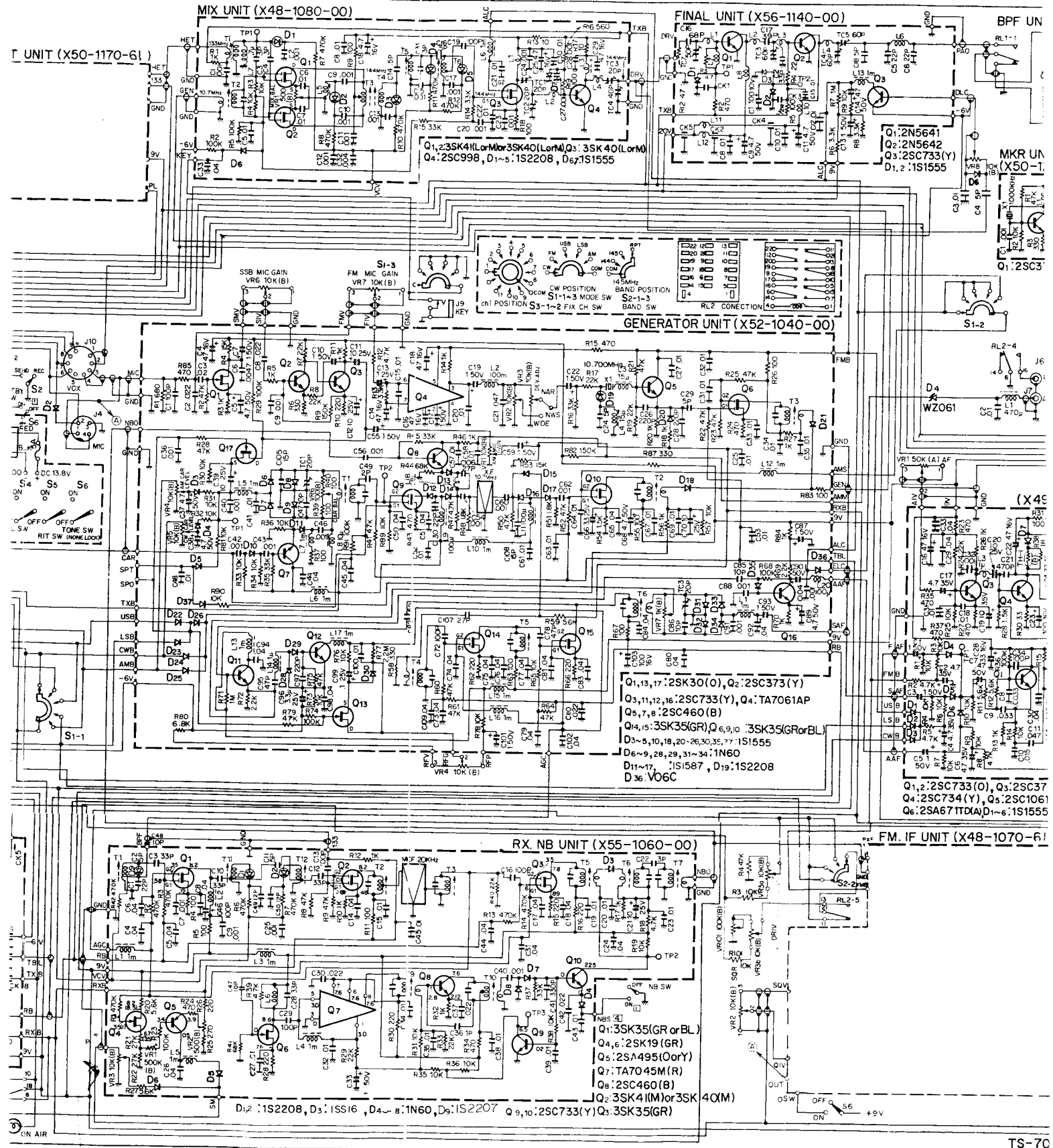



# DIAGRAM

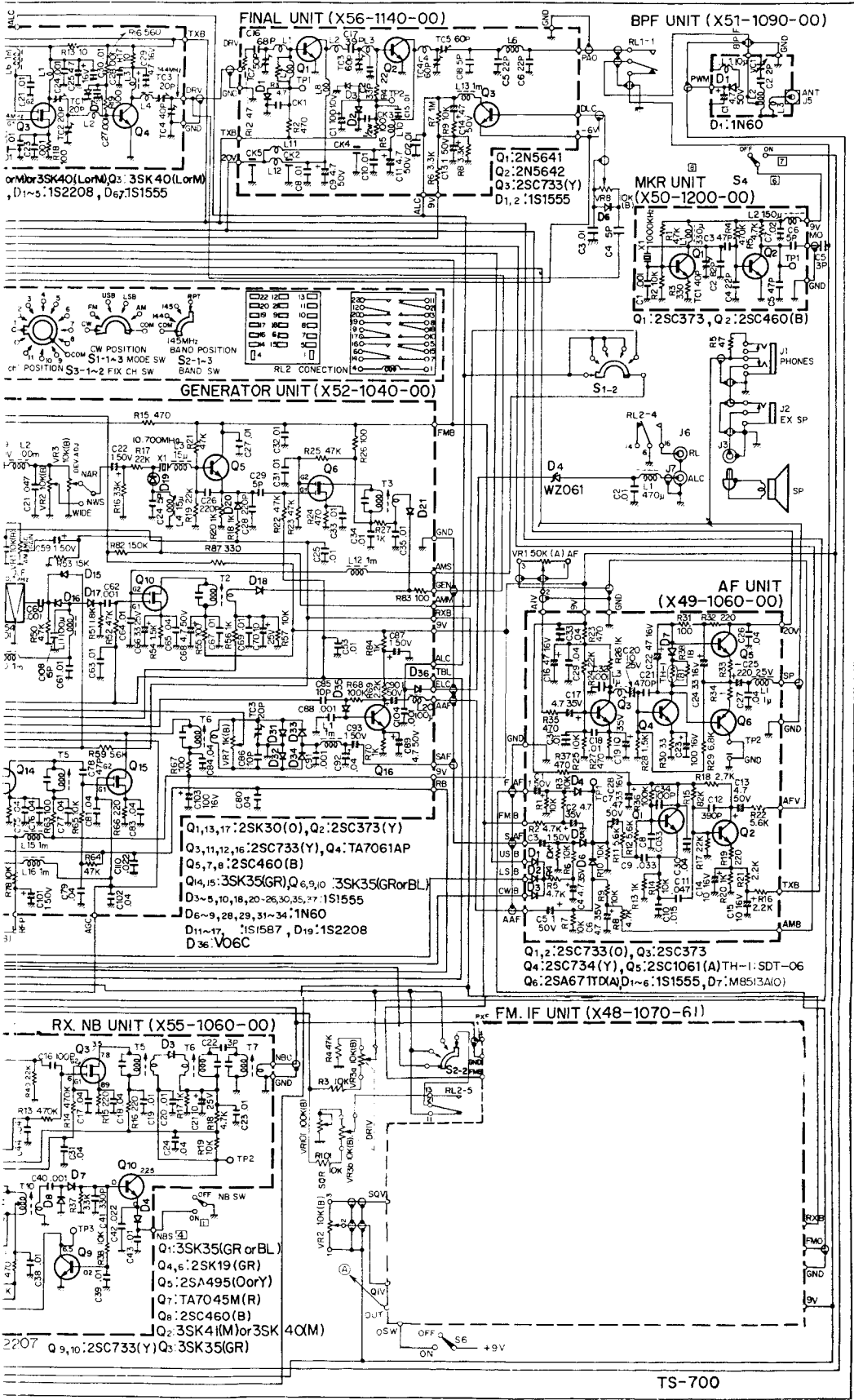

TS-700

# HET. UNIT (X50-1170-61)

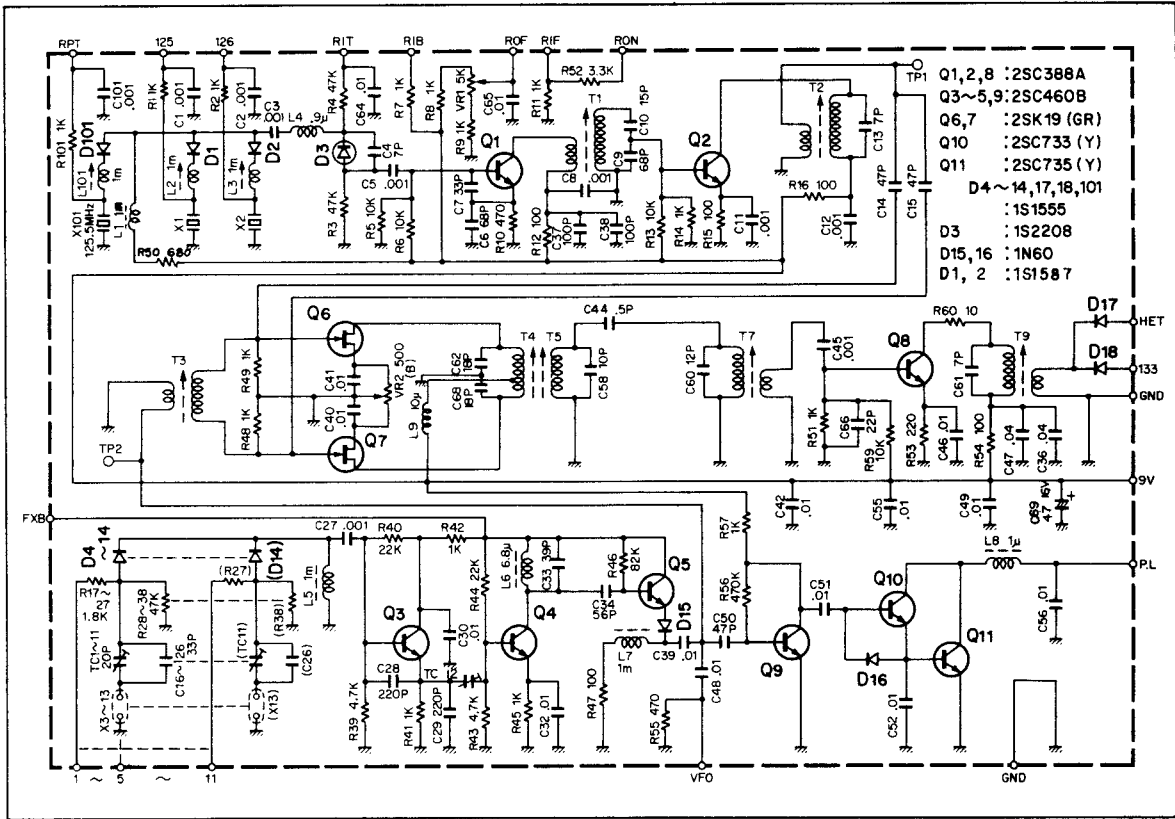

# FM. IF UNIT (X48-1070-61)

