

TK-730H(B)

SERVICE MANUAL

© 1991-12 PRINTED IN JAPAN
B51-8152-00(O)1157

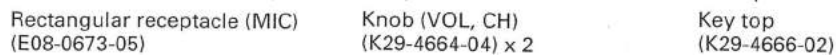
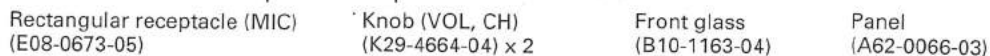
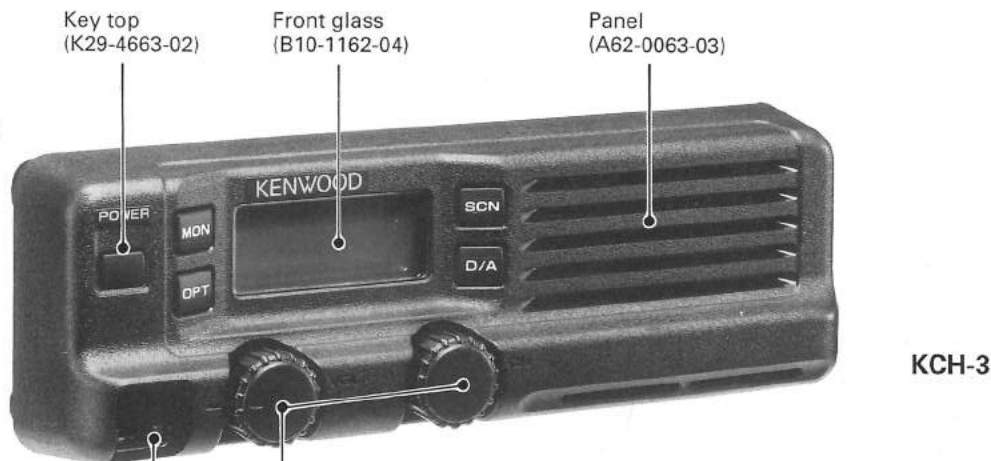
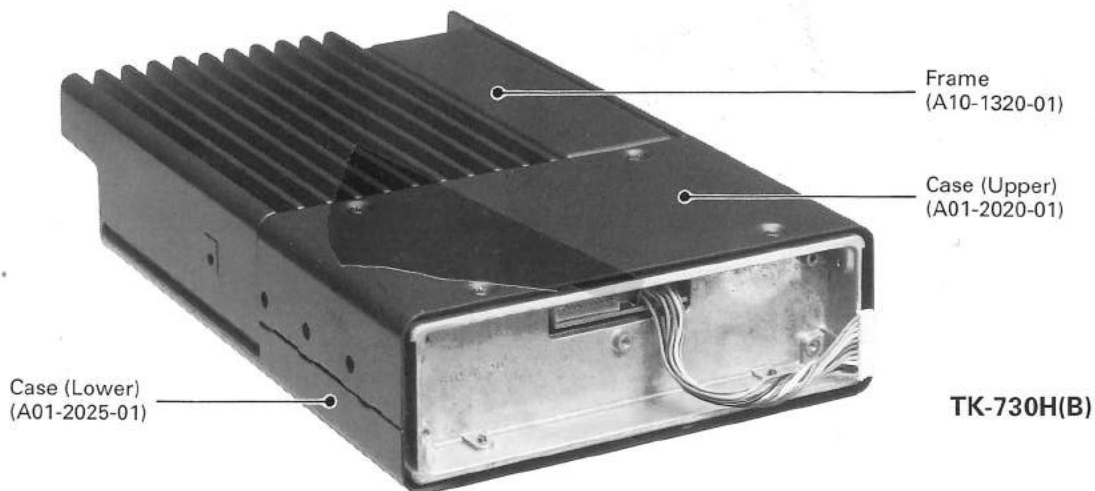

CONTENTS

GENERAL	3
SYSTEM SET-UP	5
LIST OF OPTIONAL MODELS	7
ACCESSORY & CONNECTION	8
OPERATING FEATURES	
1. SCAN Operating	9
2. Alphanumeric Display	10
3. P.A (Public Address) Function	10
4. T.A (Talk Around) Function	10
5. Time-out Timer Function	10
6. Busy Channel Lockout Function	10
7. Offhook Decode Enable Function	10
8. Dual Head Special Function (When the KRK-3DH is Used)	11
9. Transmit Audio Monitor Function	11
10. Data Writing Method	11
INSTALLATION	
1. Front Panel Kit (KCH-3, KCH-4)	13
2. KCH-6 (Optional Knob for the KCH-4)	14
3. Modification for Changing the Microcomputer Backup Time	14
4. Radio Power On/Off Function with the External Fixed Power Supply (Fixed Operation)	15
5. Auxiliary Function	16
6. OPTION (Scrambler) Function	17
7. Operator Selectable Tones/Codes Function	18
8. Ignition Sense Cable (KCT-18)	19
9. External Speaker (KES-4)	20
10. Channel Expansion Kit (KCH-5)	23
11. KXK-2 (TCXO Kit, 12.8MHz \pm 2ppm)	24
12. Horn Alert Function	26
DISASSEMBLY FOR REPAIR	26
BLOCK DIAGRAM	31
CIRCUIT DESCRIPTION	33
SEMICONDUCTOR DATA	40
DESCRIPTION OF COMPONENTS	45
PARTS LIST	48
EXPLODED VIEW	63
PACKING	66
ADJUSTMENT	69
TERMINAL FUNCTIONS	74
PC BOARD VIEWS/CIRCUIT DIAGRAMS	
DISPLAY UNIT (X54-3100-20) : KCH-3	76
DISPLAY UNIT (X54-3110-20) : KCH-4	79
VCO/PLL UNIT (X58-3810-10)	82
FIANL UNIT (X45-3390-10)	83
TX-RX UNIT (X57-3750-10)	86
SCHEMATIC DIAGRAM	93
SPECIFICATIONS	97

GENERAL

INTRODUCTION

SCOPE OF THIS MANUAL

This manual is intended for use by experienced technicians familiar with similar types of commercial grade communications equipment. It contains all required service information for the equipment and is current as of the publication data. Changes which may occur after publication are covered by either Service Bulletins or Manual Revisions. These are issued as required.

ORDERING REPLACEMENT PARTS

When ordering replacement parts or equipment information, the full part identification number should be included. This applies to all parts : components, kits, or chassis. If the part number is not known, include the chassis or kit number of which it is a part, and a sufficient description of the required component for proper identification.

PERSONNEL SAFETY

The following precautions are recommended for personnel safety :

- DO NOT transmit if someone is within two feet (0.6 meter) of the antenna.
- DO NOT transmit until all RF connectors are verified secure and any open connectors are properly terminated.
- SHUT OFF and DO NOT operate this equipment near electrical blasting caps or in an explosive atmosphere.
- All equipment should be properly grounded before power-up for safe operation.
- This equipment should be serviced by a qualified technician only.

FCC COMPLIANCE AND TYPE NUMBERS

Type acceptance number	Frequency range	Compliance
ALHTK-730H-1	150~174MHz	Parts 22, 74 and 90

GENERAL

PRE-INSTALLATION CONSIDERATIONS

1. UNPACKING

Unpack the radio from its shipping container and check for accessory items. If any item is missing, please contact KENWOOD immediately.

2. LICENSING REQUIREMENTS

Federal regulations require a station license for each radio installation (mobile or base) be obtained by the equipment owner. The licensee is responsible for ensuring transmitter power, frequency, and deviation are within the limits permitted by the station license.

Transmitter adjustments may be performed only by a licensed technician holding an FCC first, second or general class commercial radiotelephone operator's license. There is no license required to install or operate the radio.

3. PRE-INSTALLATION CHECKOUT

3-1. Introduction

Each radio is adjusted and tested before shipment. However, it is recommended that receiver and transmitter operation be checked for proper operation before installation.

3-2. Testing

The radio should be tested complete with all cabling and accessories as they will be connected in the final installation. Transmitter frequency, deviation, and power output should be checked, as should receiver sensitivity, squelch operation, and audio output. QT equipment operation should be verified.

4. PLANNING THE INSTALLATION

4-1. General

Inspect the vehicle and determine how and where the radio antenna and accessories will be mounted.

Plan cable runs for protection against pinching or crushing wiring, and radio installation to prevent overheating.

4-2. Antenna

The favored location for an antenna is in the center of a large, flat conductive area, usually at the roof center. The trunk lid is preferred, bond the trunk lid and vehicle chassis using ground straps to ensure the lid is at chassis ground.

4-3. Radio

The universal mount bracket allows the radio to be mounted in a variety of ways. Be sure the mounting surface is adequate to support the radio's weight. Allow sufficient space around the radio for air cooling. Position the radio close enough to the vehicle operator to permit easy access to the controls when driving.

4-4. DC Power and wiring

1. This radio may be installed in negative ground electrical systems only. Reverse polarity will cause the cable fuse to blow. Check the vehicle ground polarity before installation to prevent wasted time and effort.
2. Connect the positive power lead directly to the vehicle battery positive terminal. Connecting the Positive lead to any other positive voltage source in the vehicle is not recommended.

CAUTION

If DC power is to be controlled by the vehicle ignition switch, a switching relay should be used to switch the positive power lead. The vehicle ignition switch then controls DC to the relay coil.

3. Connect the ground lead directly to the battery negative terminal.
4. The cable provided with the radio is sufficient to handle the maximum radio current demand. If the cable must be extended, be sure the additional wire is sufficient for the current to be carried and length of the added lead.

5. INSTALLATION PLANNING – CONTROL STATIONS

5-1. Antenna system

Control station. The antenna system selection depends on many factors and is beyond the scope of this manual. Your KENWOOD dealer can help you select an antenna system that will best serve your particular needs.

5-2. Radio location

Select a convenient location for your control station radio which is as close as practical to the antenna cable entry point. Secondly, use your system's power supply (which supplies the voltage and current required for your system). Make sure sufficient air can flow around the radio and power supply to allow adequate cooling.

SERVICE

This radio is designed for easy servicing. Refer to the schematic diagrams, printed circuit board views, and alignment procedures contained in this manual.

SYSTEM SET-UP

Before Reading About System Set-up

The TK-730H is a transceiver main unit (without a panel or speaker) that you complete by adding options. See the list of options for the options available (page 7). The options are classified into four types according to operation and function.

1. Install the front panel kit (controller) directly on a radio to operate it. (Form : Radio + KCH-3/4)
2. Remotely control one radio with one controller. (Form : Radio + KRK-2 + KCH-3/4 + KCT-12A/B/C)
3. Remotely control two radios with one controller. (Form : Radios (two) + KRK-4DB + KCH-3/4 + KCT-12A/B/C)
4. Remotely control one radio with two controllers. (Form : Radio + KRK-3DH + KCH-3/4 (two) + KCT-12A/B/C (two))

If you use the KCH-4, an external speaker (KES-4) is required because the radio does not contain a speaker. The basic configurations are illustrated in system set-up.

Note : When you modify your radio as described in system set-up, take the following precaution. The rating of pin 7 (SB) of the accessory connector (J4) on the rear of the radio is 13.4V (1A). Insert a 1A fuse if you use the SB pin for external equipment.

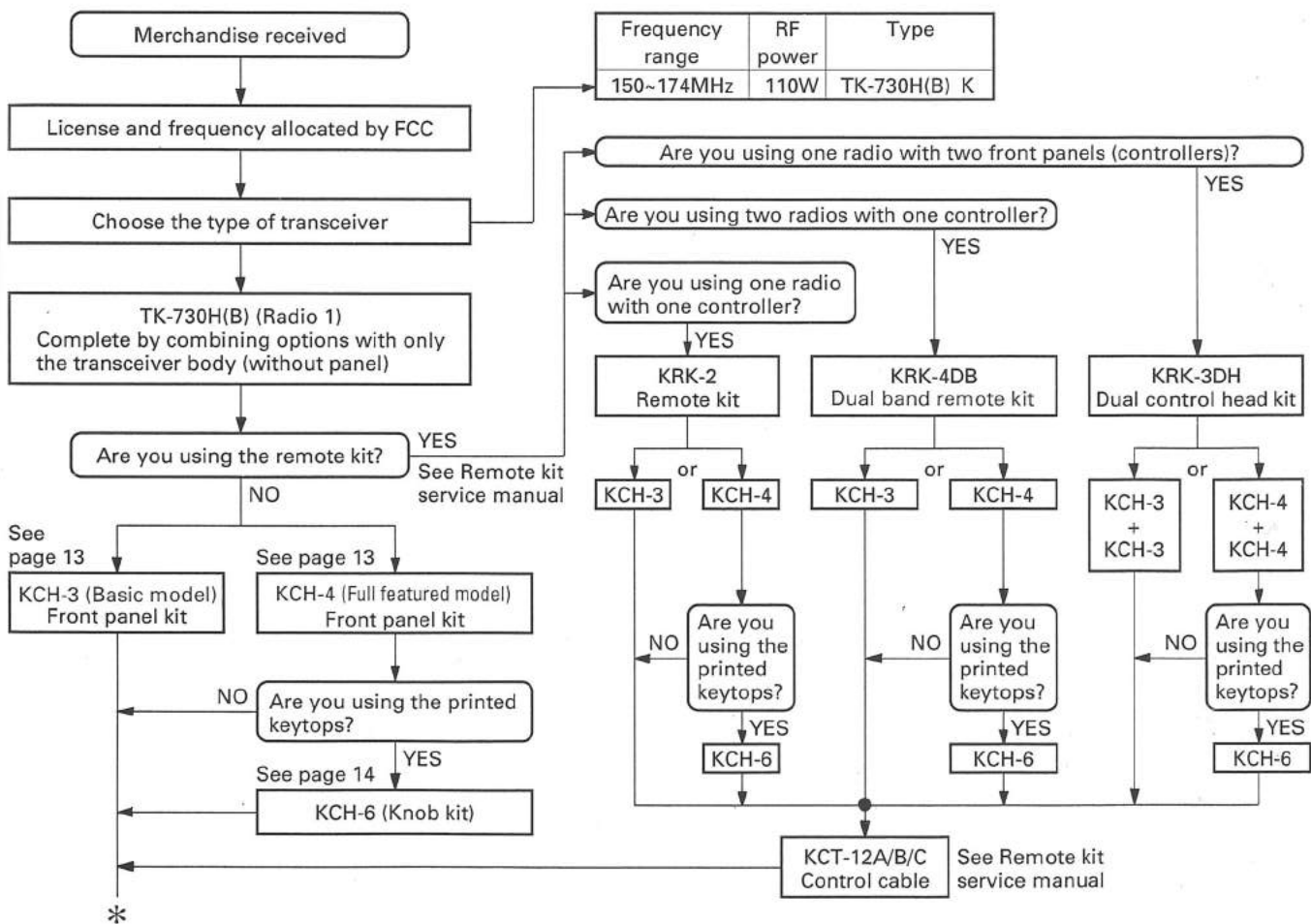
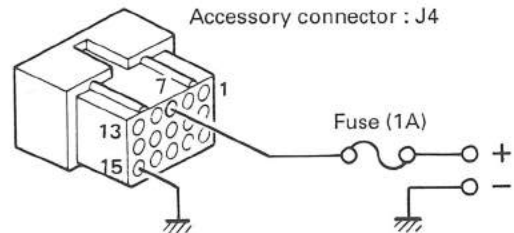
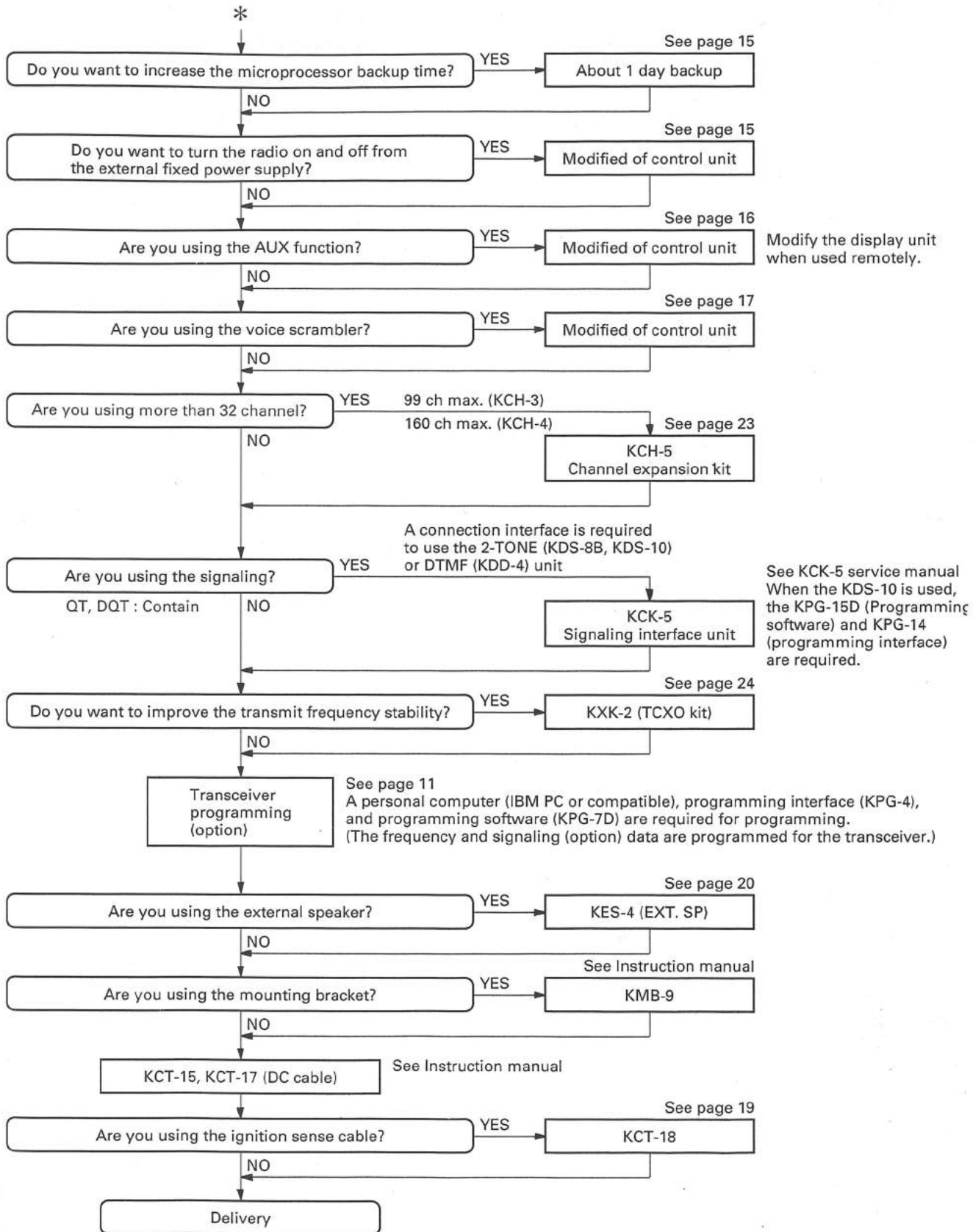

Table showing combinations of dual bands

Radio 1 \ Radio 2	TK-830H(B)	TK-730H(B)	TK-630H(B)
TK-830H(B)	X	○	○
TK-730H(B)	○	X	○
TK-630H(B)	○	○	X

○ : Can be combined, X : Cannot be combined

SYSTEM SET-UP



LIST OF OPTIONAL MODELS



Model	Function description	Remarks
KCH-3	The front panel kit (controller) contains a speaker (5W/8Ω), and can display up to 99 alphanumeric characters if a KCH-5 is installed (normally, it displays 32 channels). The channel display and alphanumeric display show two characters.	See page 13
KCH-4	The front panel kit (controller) can display up to 160 channels if a KCH-5 is installed (normally, it displays 32 channels). It has a large LCD that can display 12 alphanumeric characters. It does not contain a speaker.	See page 13
KRK-2	This single-control remote kit has a removable front panel.	See
KRK-3DH	This dual-control head kit allows one radio to be controlled by two front panel kits (controllers).	Remote kit
KRK-4DB	This dual-band remote kit allows tow radios (1 and 2) to be controlled by one front panel kit (controller). It allows two-band dual priority scan.	KRK-2/KRK-3DH KRK-4DB
KCH-6	KCH-4 keytop set. One set contains 10 keytops (PA, TA, HA, AN, IC, D/A, OPT, AUX, SP, and blank).	See page 14
KCH-5	Channel expansion kit (two EEPROMs : X24C16PI). When a basic controller (KCH-3) is used, the maximum number of channels is increased from 32 to 99. When a full-function controller (KCH-4) is used, the maximum number of channels is increased from 32 to 160.	See page 23
KCK-5	The signaling interface unit for connecting the 2-TONE (KDS-8B or KDS-10) or DTMF (KDD-4) unit is installed in the radio control unit. The externally connected equipment can be switched on and off by energizing and deenergizing the relay in the KCK-5 by the signaling output.	See KCK-5
KCT-18	The sense cable (10.5 feet) is used to turn the radio on and off with the ignition key.	See page 19
KES-4	The external speaker has a maximum input of 20W/4Ω.	See page 20
KCT-12A /12B/12C	The control cable is used to connect the radio and the control head when the radio is used as a remote mount. KCT-12A : 8 feet, KCT-12B : 17 feet, KCT-12C : 25 feet	See Remote kit
KCT-15/17	KCT-15 : DC cable (10 feet) for TK-830H(B)/730H(B)/630H(B) (high-power) system dash mounting. KCT-17 : DC cable (23 feet; ground side : 3.3 feet) for TK-830H(B)/730H(B)/630H(B) (high-power) system remote mounting.	See Instruction manual
KDS-8B	2-TONE decoder. The tone frequency can be in the range 288 to 1433Hz.	See KCK-5
KDD-4	Code memory (EEPROM). (DTMF decoder)	See KCK-5
KDS-10	2-TONE frequency memory (EEPROM). The tone frequency can be set in the range 282.2 to 3487.0Hz in 0.1Hz steps.	See KDS-10
KPG-15D	Programming disk used to program the KDS-10 (2-TONE decoder).	See KDS-10
KPG-14	Programming interface used for the KDS-10.	See KDS-10
KXK-2	TCXO kit (12.8MHz ± 2ppm). Replace it with X302 of the radio TX-RX unit. This kit cannot be used for the TK-630H(B).	See page 24
KMB-9	Mounting bracket for remote mount or dash mount. Key lock mount is provided.	See Instruction manual

Service Manual Parts List

Model	Parts No.
KRK-2/KRK-3DH/KRK-4DB	B51-8154-00
KCK-5	B51-8155-00
KDS-10	B51-8156-00

TK-730H(B)

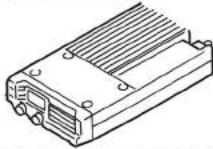
ACCESSORY & CONNECTION

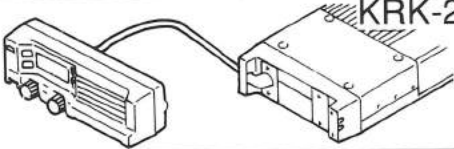
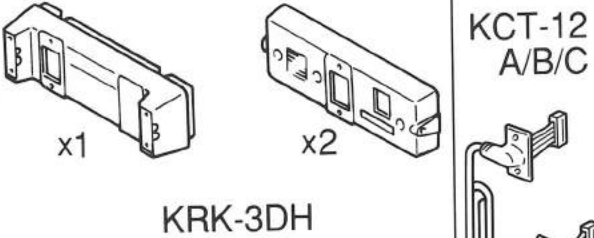
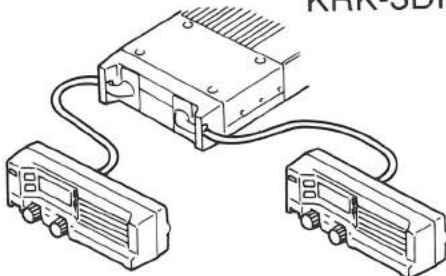
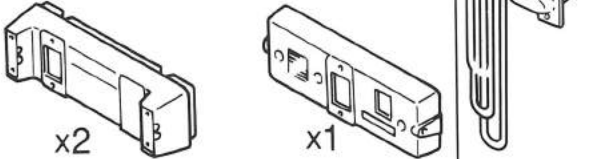
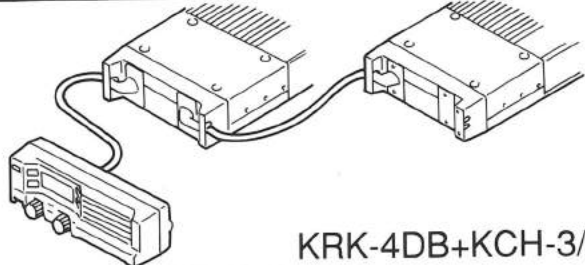
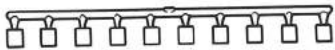
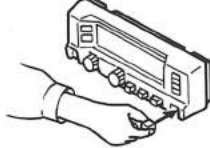
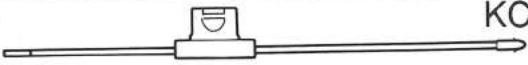
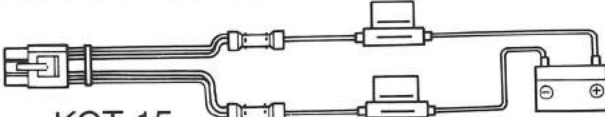
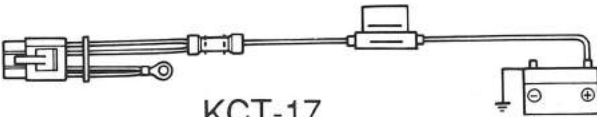
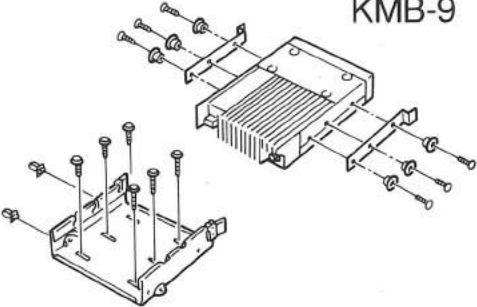
ACCESSORY	CONNECTION
 <p>KCH-3 KCH-4</p>	
 <p>KRK-2</p>	 <p>KRK-2+KCH-3/4</p>
 <p>x1 x2</p> <p>KRK-3DH</p> <p>KCT-12 A/B/C</p>	 <p>KRK-3DH+KCH-3/4</p>
 <p>x2 x1</p> <p>KRK-4DB</p>	 <p>KRK-4DB+KCH-3/4</p>
 <p>KCH-6</p>	 <p>KCH-6+KCH-4 only</p>
 <p>KCT-18</p>	
 <p>KCT-15</p>	 <p>KCT-17</p>
 <p>KMB-9</p>	

OPERATING FEATURES

1. Scan Operating

1-1. Scan types according to operation section (control head: KCH-3/4)

1. When you use the KCH-3 (basic), you can scan all the channels that can be selected with the channel selector.
2. When you use the KCH-4 (full featured), you can select one of the following two scan types using the programming software (KPG-7D).
 - 2-1. Single group scan : You can scan all the channels in the displayed group that can be selected with the channel selector.
 - 2-2. Multi-group scan : You can scan all the channels that can be selected with the group UP/DOWN key and the channel selector.

1-2. Scan start conditions

One or more non-priority channels must be added to all the channels that can be scanned. The transceiver must be in normal receive mode (PTT off, and microphone onhook). When you press and release the SCAN key, the scan starts. The **SCN** indicator lights when you use the KCH-3 (basic), and the **SCAN** indicator lights when you use the KCH-4 (full featured).

1-3. Scan stop conditions

The scan stops temporarily if the following conditions are satisfied :

1. A carrier is detected (the **BUSY** indicator lights) on channels for which receive signaling is not set by the programming software (KPG-7D) or when the **MON** indicator lights.
2. A carrier is detected, then signaling matches on channels for which receive signaling is set by the programming software.

1-4. Scan channel types

1. Priority channel 1 is the most important channel for the scan, and always detects a signal during scan and when the scan stops temporarily.
2. Priority channel 2 is the next most important channel for the scan, and always detects a signal during scan and when the scan stops temporarily at a channel other than priority channel 1.
3. Non-priority channels detect a signal during scan. For the channels that can be selected with the group or channel selector when the scan does not occur, **▼** (CH ADD) lights for the KCH-3 (basic), and **▼** (GR ADD) and **▼** (CH ADD) light for the KCH-4 (full featured).

1-5. Priority channel setting

Priority channels 1 and 2 can be set as follows with the programming software (KPG-7D) :

1. Specify priority channels 1 and 2 as fixed priority channels.
2. Make selected channels priority channels.
3. Operator selectable; specify the initial channel before the operator changes it.

1-6. Scan types according to the number of priority channels

1. When no priority channels are set : Only the non-priority channels are scanned. If a non-priority channel stops temporarily, it stops until there is no signal on that channel.
2. When one priority channel is set : Either priority channel 1 or 2 is scanned. If a non-priority channel stops temporarily, a priority channel signal is detected at certain intervals. If a priority channel stops temporarily, it stops until there is no signal on the priority channel.
3. When two priority channels are set : The non-priority channel, priority channel 1 and 2 are scanned. If a non-priority channel stops temporarily, priority channel 1 and 2 signals are detected at certain intervals. If priority channel 2 stops temporarily, the priority channel 1 signal is detected at certain intervals. If priority channel 1 stops temporarily, it stops until there is no signal on priority channel 1.

1-7. Offhook revert channel

The offhook revert channel stops the scan temporarily by shifting the channel when the transceiver user sets the microphone offhook to transmit during scanning, or when the scan stops temporarily. It can be selected by the programming software (KPG-7D).

1. Priority 1 *
2. Priority 2 *
3. Selected channel : Channel displayed immediately before you operate the SCAN switch under the above scan start conditions.
4. Last-used channel : Channel at which the transceiver user pressed PTT just before he set the transceiver offhook.
5. Last call channel : Channel at which the user canceled the AF mute, except beep and alert, just before he set the transceiver offhook.

* If priority channel 1 or 2 is not set by the programming software (KPG-7D) or if the transceiver user deletes (the **▼** indicator lights), the channel shifts to the selected channel, last-used channel, or last call channel, and stops temporarily.

OPERATING FEATURES

1-8. Scan end

If you press and release the SCAN key when the **SCN** or **SCAN** indicator is on and the transceiver is not transmitting, the scan ends, the **SCN** or **SCAN** indicator goes off, and the transceiver switches to the selected channel automatically.

2. Alphanumeric Display

The programming software (KPG-7D) enables you to set the alphanumeric display (2 digits for the KCH-3; 12 digits for the KCH-4) as shown in Figure 1.

Display →	A	B	C	D	E	F	G	H	I
Key in →	A	B	C	D	E	F	G	H	I
	J	K	L	M	N	O	P	Q	R
	J	K	L	M	N	O	P	Q	R
	S	T	U	V	W	X	Y	Z	'
	S	T	U	V	W	X	Y	Z	'
	1	2	3	4	5	6	7	8	9
	1	2	3	4	5	6	7	8	9
	0	-	+	/	=	#	*	,	;
	0	-	+	/	=	#	*	,	;
	<			←	█	←	All on	Blank	
	<			←	█	←	All on	Blank	
	(-	 		Space →	→	
	(-			Space →	→	

Fig. 1

3. P.A (Public Address) Function

Available for a transceiver to which an optional public address speaker (KES-4) is connected via the accessory connector (J4).

The public address function amplifies the voice input from the microphone with a BTL-type audio amplifier with a 13W (4Ω) rated output, and outputs it from the public address speaker. The transceiver does not enter the transmit mode when this is done.

When you press and release the key set as the P.A switch by the programming software (KPG-7D), the KCH-3 (basic) shows P.A, and the KCH-4 (full featured) shows PUBLIC **□**ADRS **□**, and the transceiver becomes ready to output your voice from the speaker. If you press PTT and talk into the microphone, your voice is output from the speaker. The volume of the public address speaker can be adjusted with the AF VR of the operation section (control head) that controls the PTT.

If dual band is used with the KRK-4DB (dual-band remote kit), the voice signal is output from the accessory connector (J4) of radio 1.

4. T.A (Talk Around) Function

The talk around function enables you to talk with the other party directly without using a repeater on the channel that has a repeater. This function makes the transmit frequency and signaling equal to the receive transmit frequency and signaling, and transmits data.

When you press and release the key set as the T.A switch by the programming software (KPG-7D), the **TA** indicator lights and the talk around function is enabled.

5. Time-out Timer Function

You can select 15 to 225 seconds (15-second units) or set this function off with the programming software (KPG-7D).

If you do not set the function off, and the time from the transceiver entering the transmit mode to returning to the receive mode exceeds the preset time, the transmission ends and a warning tone is output. The warning tone sounds until you release PTT.

When you release PTT, the timer is cleared.

6. Busy Channel Lockout Function

You can set this function on and off with the programming software (KPG-7D).

If you set it on, and there is no signaling or a signaling-unmatched signal is input in receive mode on the channel for which receive signaling is set, you cannot enter the transmit mode even if you press PTT, and a warning tone is output until you release PTT.

This function does not work while the **MON** indicator is lit.

7. Offhook Decode Enable Function

You can set this function on and off with the programming software (KPG-7D).

If you set it off, you cannot cancel signaling during offhook. This function only cancels signaling, and does not affect the offhook revert channel during scanning.

OPERATING FEATURES

8. Dual Head Special Function

(When the KRK-3DH is Used)

See the KRK-3DH service manual for the assembly method.

8-1. Intercom function

The intercom function enables you to make conversation between control head 1 and control head 2. The transceiver does not enter the transmit mode when you use this function. You can talk in simplex mode.

When you press and release the key set as the IC (intercom) key by the programming software (KPG-7D), the KCH-3 (basic) shows IC, and the KCH-4 (full featured) shows \square INTERCOM \square to indicate that you can talk. If you press PTT and talk into the microphone, your voice is output from the speaker of the other control head. The speaker volume can be adjusted with the AF VR on the other operation section (panel).

9. Transmit Audio Monitor Function

You can set this function on and off with the programming software (KPG-7D).

If you set it off, and you press PTT on control head 1 or 2, your voice is transmitted when you talk into the microphone, but it is not output from the speaker of control head 2 or 1 to prevent howling.

If you set it on, your voice is transmitted and output from the speaker of the other control head. The contents of the transmission are heard, and you can understand what is being said.

10. Data Writing Method

10-1. PC programming method

• Preparation

Install optional front panel kit KCH-3 or KCH-4 (see Installation 1), and do as follows :

• Preface

The TK-730H transceiver is programmed by using a personal computer, programming interface (KPG-4), and programming software (KPG-7D).

The programming software can be used with an IBM PC or compatible. Figure 2 shows the setup of an IBM PC for programming.

• KPG-4 description

(P.C. programming interface cable : Option)

The KPG-4 is required to interface the TK-730H to the computer. It has a circuit in its D-subconnector (25 pin) case that converts the RS-232C logic level to the TTL level.

The KPG-4 connects the front panel modular microphone connector of the TK-730H to the computer RS-232C serial port.

• Programming software description

The KPG-7D is the programming software for the TK-730H supplied on a 5.25" and 3.5" floppy disk.

This software runs under MS-DOS (Version 3.1 or later) on an IBM-PC/XT, AT, or PS2, or compatible. Data can be input to or read from the TK-730H and edited on the screen, and programmed data can be printed.

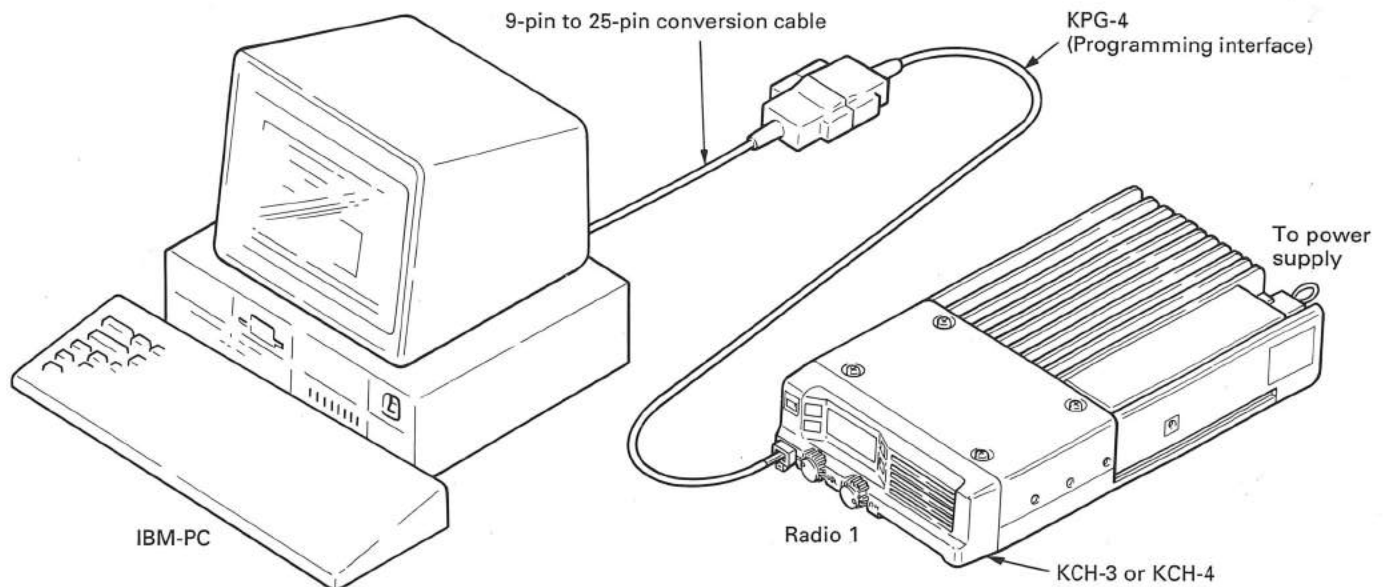

Fig. 2

OPERATING FEATURES

• Program mode

After you finish preparatory, you can write data into the EEPROM of the radio (TK-730H).

The KCH-3 can associate the optional functions with the four switches (MON, SCN, OPT (KEY1), and D/A (KEY2)) using the PC program.

The KCH-4 can associate the optional functions with the six switches (MON, SCN, KEY1 to KEY4).

For example, you can assign a function to KEY1 as follows when you assign functions to the KCH-3/4 switches (MON, SCN, KEY1 to KEY4) :

Note : See page 13 for the LCD readout and error messages.

1. Hold down the KEY1 key (until "PG" (basic) or "PROGRAM" (full featured) appears), and switch the radio on. (See Figure 3-a and 3-b.)
2. "PG" (KCH-3) or "PROGRAM" (KCH-4) appears on the display. Release the KEY1 key.
3. Transfer the data stored in the PC. The data is written into the EEPROM of the radio.

Notes :

If dual control is used (KRK-3DH is used), use the HEADER of HEAD1. ("TO CONTROL HEAD1" is shown on the rear of the KRK-3DH.)

If dual band is used (KRK-4DB is used), supply power to radios 1 and 2.

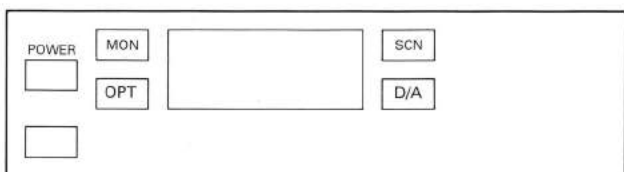

Fig. 3-a KCH-3 (basic) functions

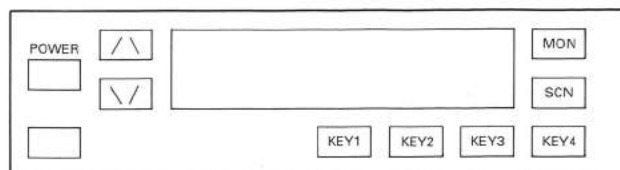

Fig. 3-b KCH-4 (full) functions

10-2. Writing by the clone function

Programming data can be transferred from one radio to another by connecting them at their microphone connectors. (The two radios must be of the same model to use this function.) The operation is as follows (the transmit radio is the master unit and the receive radio is a slave unit) :

1. Hold down the KEY1 key (until "PG" (KCH-3) or "PROGRAM" (KCH-4) appears), and switch the master and slave units on. (See Figure 3-a and 3-b.)
2. Connect the master and slave units with a microphone cable. (See Figure 4.)
3. Hold down the **MON** key on the master unit. Hold it down until "CL" (KCH-3) or "CLONE" (KCH-4) appears on the display.
4. Press the **SCN** key.
5. The display shows "MAX → 3 → 2 → 1 → EN" (KCH-3) or "MAX → 3K → 2K → 1K → END" (KCH-4). When EN or END appears, writing is complete.

Notes :

See page 13 for the LCD read out and error messages. If dual control is used (KRK-3DH is used), use the HEADER of HEAD1 for cloning. ("TO CONTROL HEAD1" is shown on the rear of the KRK-3DH.)

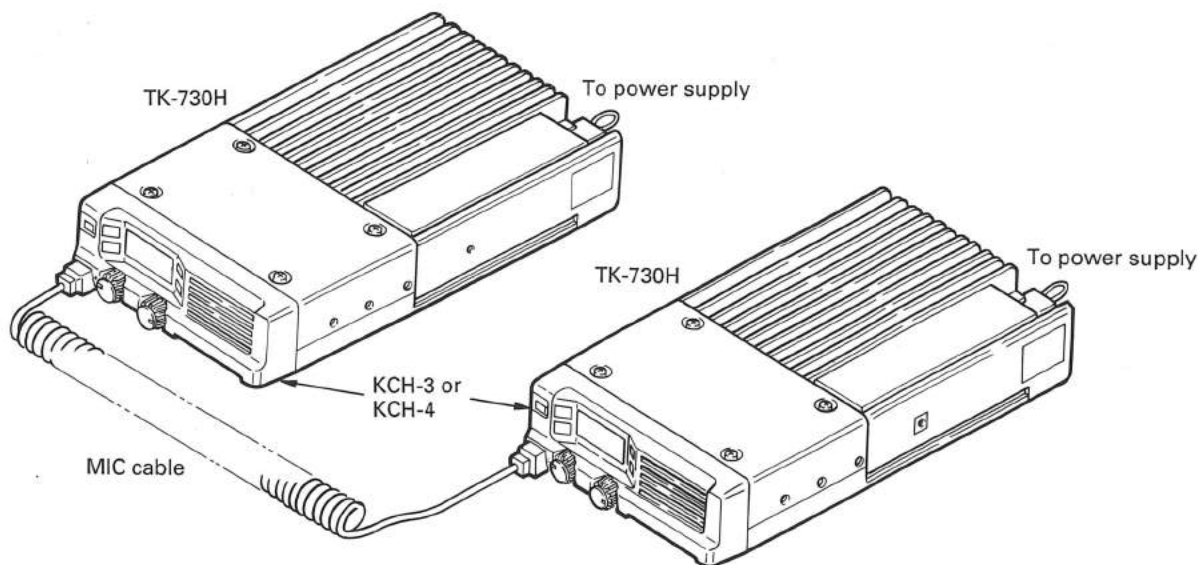

Fig. 4

OPERATING FEATURES/INSTALLATION

10-3. LCD readout examples (program mode)

Status	When KCH-3 is used	When KCH-4 is used
Program mode readout	PG	_PROGRAM_
Clone master unit readout	CL	_CLONE_
Data transfer readout (remaining quantity readout)	20 _1	_WAIT_32K_ _WAIT_1K_
Data transfer start readout	EX	_EXECUTION_
Data transfer end readout	EN	_END_
Error message (*1)	ER	_ERROR_
Error message (*2)	E1	CH_OFFLINE_
Error message (*3)	E2	_MISMATCH_
Error message (*4)	E3	CAN'T_WRITE_

Readout examples in program mode

• Description of error messages

(*2, *3, and *4 are displayed only on the master unit during cloning.)

*1 : ER (ERROR)

PC programming error readout
Slave unit error readout during cloning

*2 : E1 (CH OFFLINE)

Master unit error readout during cloning ; The data line is not connected. (Cable connector error, broken cable, etc.)

*3 : E2 (MISMATCH)

Master unit error readout during cloning ; The model name is different.

*4 : E3 (CAN'T WRITE)

Master unit error readout during cloning ; Cannot write due to a cause not given by 2 and 3 (defective EEPROM, etc.)

1. Front Panel Kit (KCH-3, KCH-4)

1-1. Connection with TK-730H

1. Remove the upper and lower halves of the case of the TK-730H. (Remove the four screws from the upper half and the six screws from the lower half.)
2. Connect the lead (W105) with a connector of the control unit (X57-3750 A/3) to CN2 of the KCH-3 or KCH-4.
3. Install the KCH-3 or KCH-4 on the radio using the screws (N32-3006-46) (1) supplied with the front panel kit. Take care not to get the lead between the KCH-3 or KCH-4 and an edge of the case. (You can install the panel upside down if necessary to install the radio.)
4. Reinstall the upper and lower halves of the case.

Note : The split legends (A/3 to C/3) of the control, TX-RX, and AF units shown in this manual are different from those silk-printed on the PC board. They are listed below.

Unit name	Service manual	PC board silk print
Control	X57-3750-10 A/3	X57-3750-10 A/4
TX-RX	X57-3750-10 B/3	X57-3750-10 B/4
AF	X57-3750-10 C/3	X57-3750-10 C/4

PC board split legend

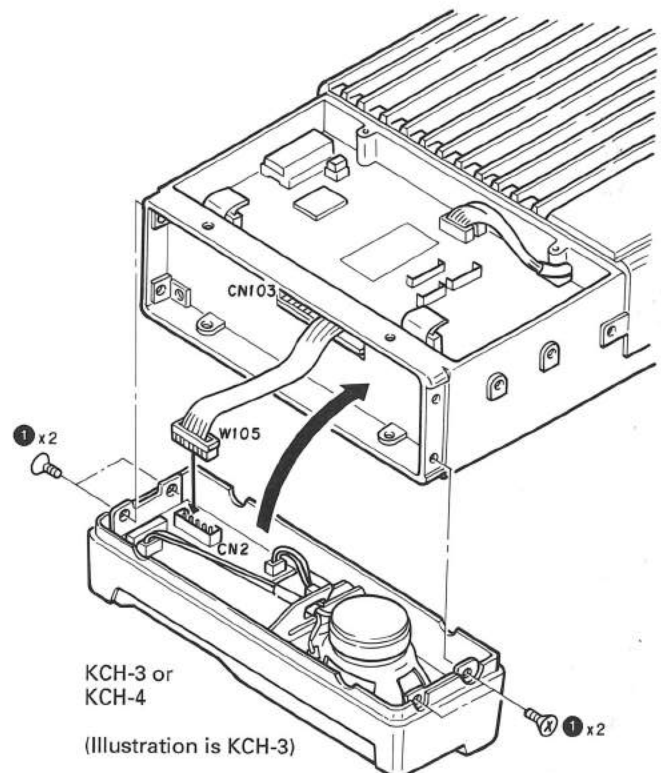

Fig. 1

INSTALLATION

5. Insert the supplied knobs (with no functions printed) or optional KCH-6 (knobs with functions printed) into KEY1 to KEY4 of the KCH-4. Insert the knobs with their dents facing downward. (Fig. 2-a)

Note : To remove a knob, insert a screwdriver into the dent of the knob from underneath. (Fig. 2-b)

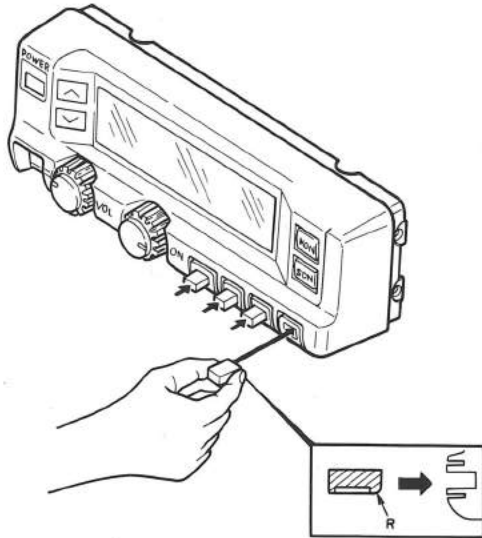

Fig. 2-a Knob insertion

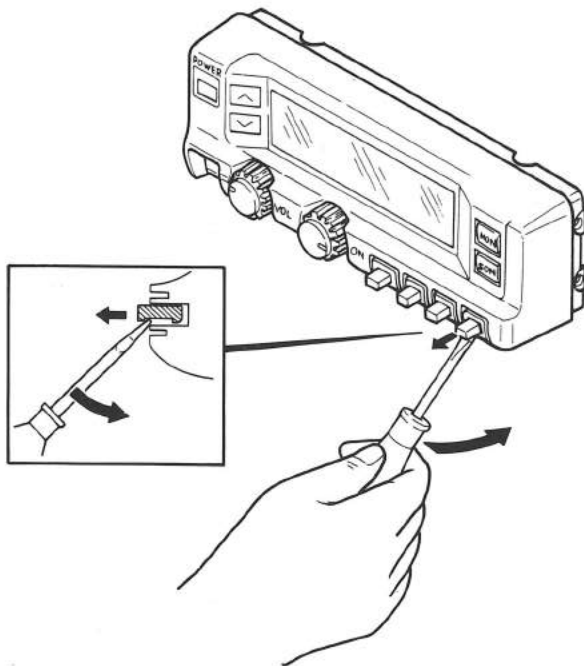

Fig. 2-b Knob removal

1-2. Remote kit connection

See the service manuals for the KRK-2, KRK-3DH, and KRK-4DB.

2. KCH-6 (Optional Knob for the KCH-4)

When a function is set by the programming software (KPG-7D), the key legend can be changed by inserting the KCH-6 knob into KEY1 to KEY4 of the KCH-4. The KCH-6 contains a set of 10 knobs : PA, HA, TA, IC, AN, SP, D/A, OPT, AUX, and blank.

2-1. Installation method

See Item 5 above. (Fig. 2)

3. Modification for Changing the Microcomputer Backup Time

3-1. Mobile operation

When this radio is connected to a car battery, the microcomputer is always backed up. (The RAM contents are retained regardless of whether you turn the radio power switch on or off.) If you disconnect the battery from the radio, the RAM contents disappear in a short time.

3-2. Fixed operation

If the power switch of the fixed power supply connected to the radio is on, the microcomputer is always backed up regardless of whether you turn the radio power switch on or off. If the power switch of the fixed power supply is off, the RAM contents disappear in a short time.

INSTALLATION

3-3. Backup function modification

The minimum backup time when the radio power is off can be changed to one day by making the following modification :

1. Remove the upper half of the radio case.
2. Remove the control unit (X57-3750 A/3) from the chassis.
3. Add C217 to the control unit. (Pay attention to the polarity.) C217 : 0.047F (C90-2079-05)

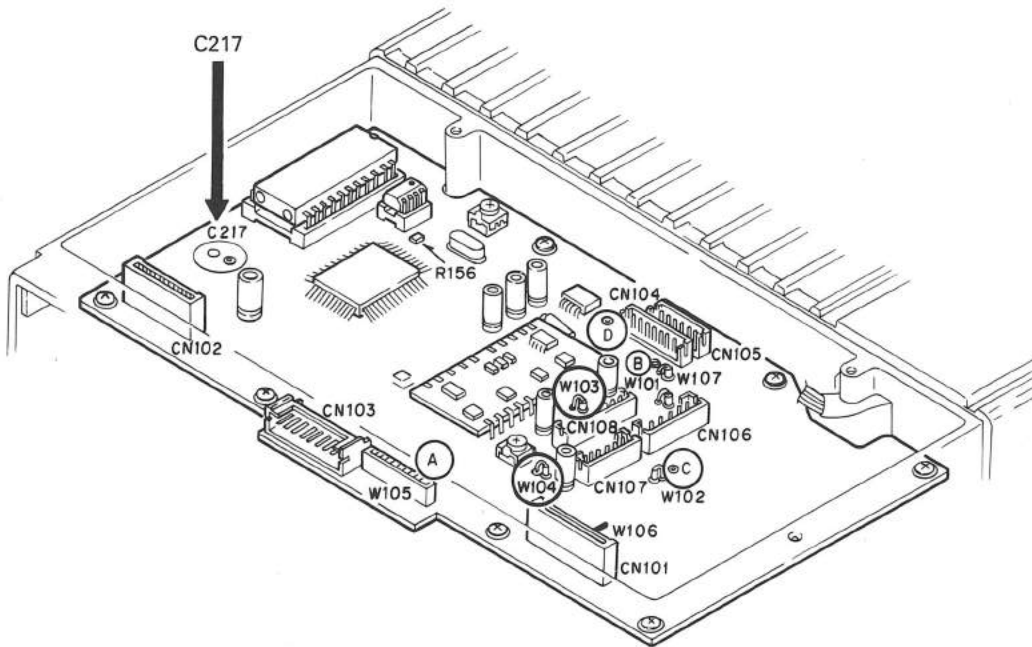

Fig. 3

4. Radio Power On/Off Function with the External Fixed Power Supply (Fixed Operation)

If you modify the radio as follows, the radio power can be turned on by turning on the power switch of the power supply, even if the radio power switch is off. If the radio power switch is turned off, and the power is switched off, then on again immediately, this function does not work ; switch the radio power on.

4-1. Modification method

1. Remove the upper half of the radio case.
2. Remove the control unit (X57-3750 A/3) from the chassis. See the rear of the PC board.
3. Remove R105 (R92-0670-05) from the control unit, and install it on the pattern next to R106.

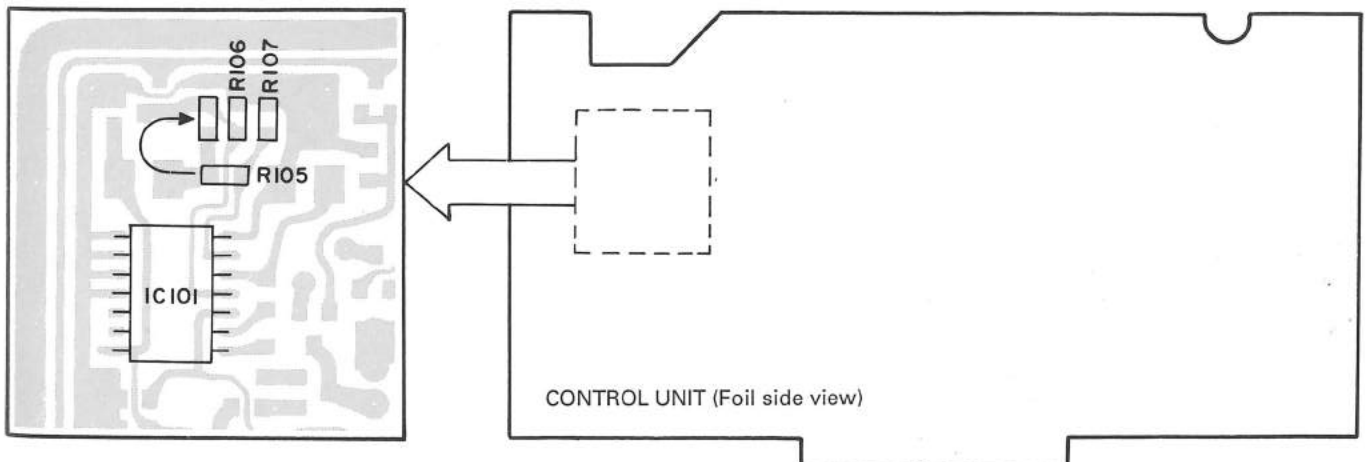

Fig. 4

INSTALLATION

5. Auxiliary Function

The programming software (KPG-7D) enables you to assign an auxiliary function to the AUX key. When you press the AUX key, "•" lights on the KCH-3, and "AUX" lights on the KCH-4, and the auxiliary function turns on.

When you press the AUX key again, "•" or "AUX" goes off, and the auxiliary function turns off. When you set the AUX key on, the display backlight (LED) goes off; when you set the AUX key off, the display backlight (LED) goes on.

The auxiliary function can be assigned to the OPT key using the programming software (KPG-7D). If this is done, "OPT" appears, and the OPT key works like the AUX key.

5-1. Radio modification

The control unit of the radio has a pattern marked with a D, and contains switching transistor Q116, which drives pattern D. The control unit (X57-3750 A/3) IC105 pin 7 goes high when the AUX key is turned on, and low when the AUX key is turned off. So when the AUX key is turned on and off, Q116 output D (max. 100mA) turns on and off. Connect D to a desired port.

5-2. Modification method if remote kit (KRK-2, KRK-3DH, or KRK-4DB) is used

If you use a remote kit and modify it as follows, you can turn pin 3 (AUX) of the accessory connector (6-pin) on the rear of the control head on and off by turning the AUX key on and off. You can use pin 3 to control external equipment.

1. If you use the KCH-3 (basic control head), remove R20 from the display unit (X54-3100 A/2) with a soldering iron. (Fig. 6-a)
2. If you use the KCH-4 (full-featured control head), remove R35 from the display unit (X54-3110 A/2) with a soldering iron. (Fig. 6-b)
3. You can control external equipment by connecting it to pin 3 (AUX) of the plug (6-pin : P703/P704) of the accessory connector (6-pin) on the rear of the control head. (Fig. 6-c)

5-3. Backlight on/off function

When you set the auxiliary function, the backlight on/off function is also set. To set the auxiliary function without setting the backlight on/off function, modify the TK-730H as described in Section 5-2.

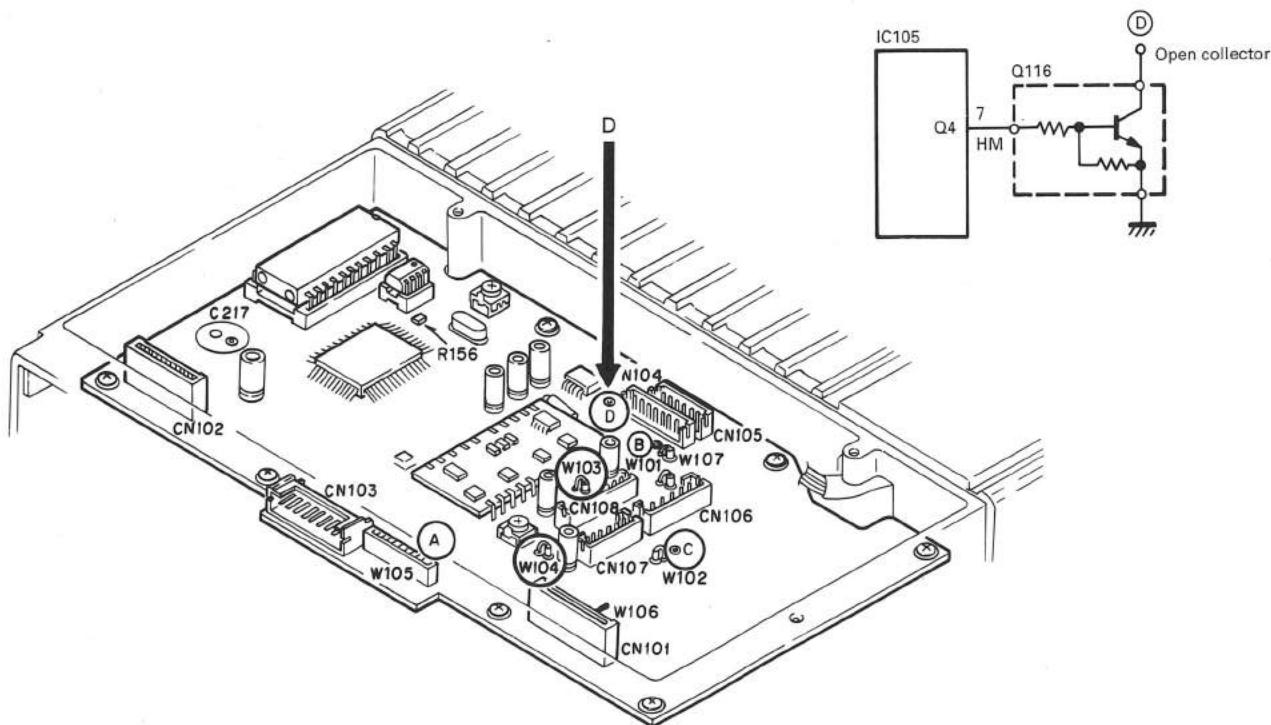

Fig. 5

INSTALLATION

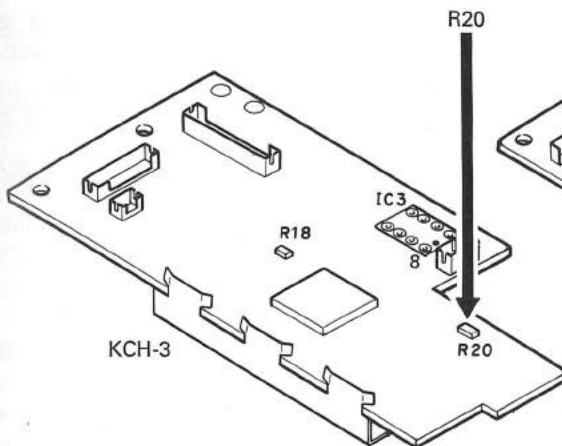

Fig. 6-a

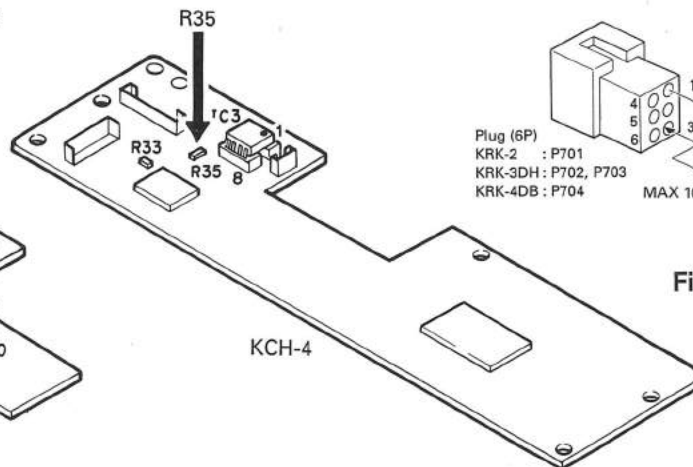

Fig. 6-b

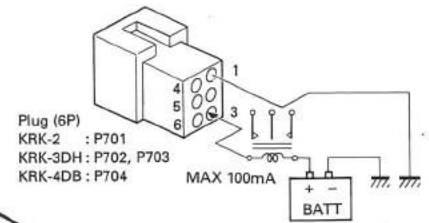

Fig. 6-c

6. OPTION (Scrambler) Function

This function is available when you assign it to the OPT key with the programming software (KPG-7D). When you press the OPT key, the "OPT" indicator lights, and the OPTION (Scrambler) function turns on. When you press the key again, the "OPT" indicator goes off, and the OPTION (Scrambler) function turns off.

The OPTION (Scrambler) function can be assigned to the AUX key using the programming software (KPG-7D). If this is done, "•" (KCH-3), "AUX" (KCH-4) appears, and the AUX key works like the OPT key.

Normally, the OPTION (Scrambler) function operates the port of connector CN108 of the control unit (X57-3750 A/3) as follows :

6-1. AC1 (pin 5)

AC1 is normally high (OPT : Off). When you press the OPT key, AC1 goes low, and the "OPT" indicator lights. When you press the key again, AC1 goes high and the "OPT" indicator goes off.

6-2. Ports 0, 2, 4, and 8 (pins 9 to 12)

Data stored in the RAM is output as the initial data. It is 0000 when the microcomputer is reset.

If you hold down the SCN key and press the OPT key, you enter the code setting mode, and "1" to "16" (KCH-3) or "CODE1" to "CODE16" (KCH-4) appears on the display. When you set codes, the port output is changed from 1 to 16 by changing the display from 0 to F with the encoder. If you hold down the OPT key again, the code setting mode is terminated, and the set code for the port remain unchanged.

6-3. Voice scrambler connection example

• Modification method

1. Remove the upper half of the case of the TK-730H. (Four screws)
2. Cut W103 and W104 of the control unit (X57-3750 A/3).

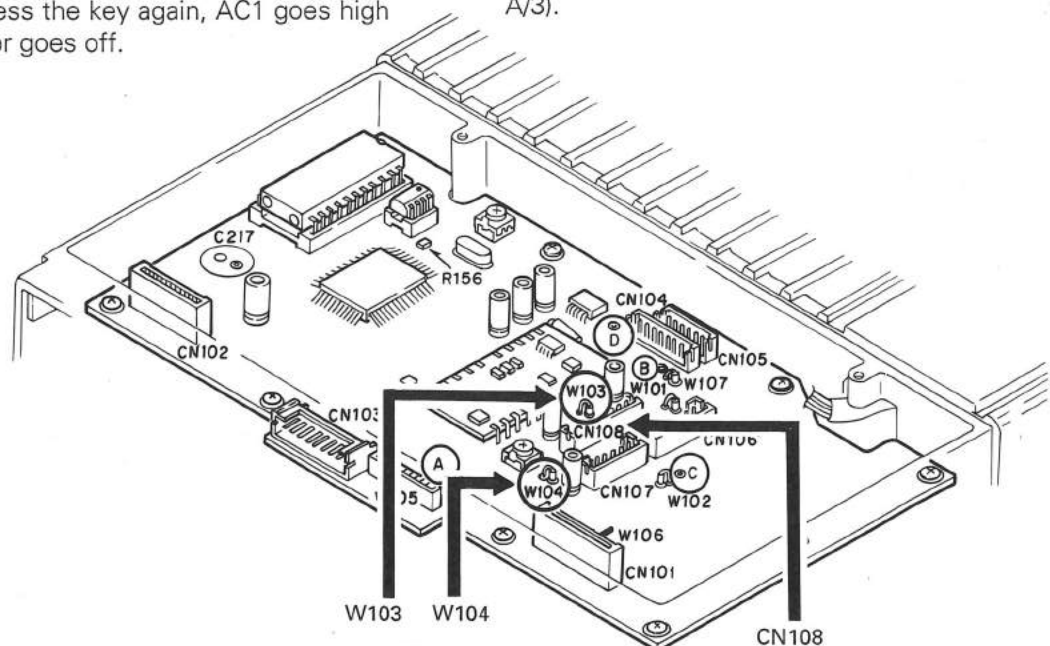

Fig. 7

INSTALLATION

• Connection method

Connect control unit (X57-3750 A/3) CN108 and the voice scrambler as follows :

• Operation method

1. When you press the OPT key, the scrambler is activated and scrambles. The "OPT" indicator lights.
2. When you press the OPT key again, the scrambler is deactivated and the "OPT" indicator goes off.
3. Set the scrambler code with the encoder as described in Section 6-2.

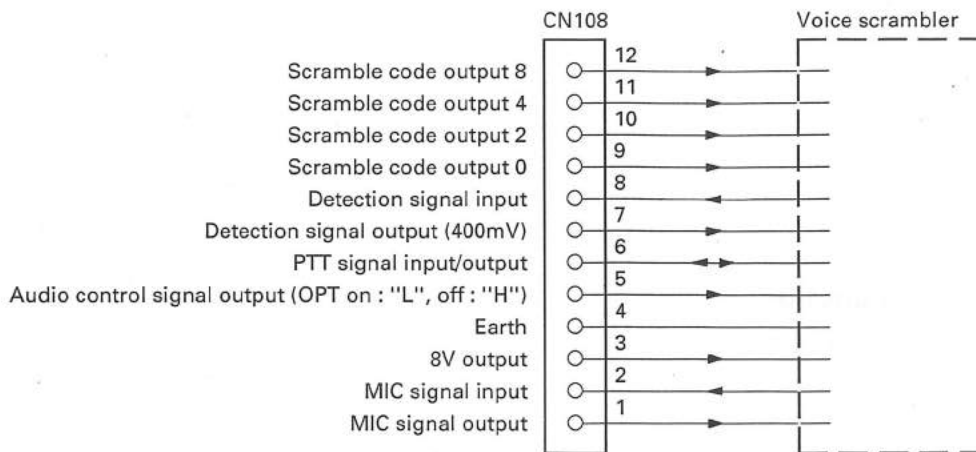

7. Operator Selectable Tones/Codes Function

This function is available when you assign it to the OPT key with the programming software (KPG-7D). When you press the OPT key, the "OPT" indicator lights, and the operator selectable tones/codes function turns on. When you press the key again, the "OPT" indicator goes off, and the operator selectable tones/codes function turns off.

The operator selectable tones/codes function can be assigned to the AUX key using the programming software (KPG-7D). If this done, "•" (KCH-3), "AUX" (KCH-4) appears, and the AUX key works like the OPT key.

7-1. Setting the operator selectable tones/codes

When you assign the operator selectable tones/codes function to the OPT key using the programming software (KPG-7D), you should use the programming software to set a maximum of 16 operator selectable tones/codes in addition to the operator selectable tones/codes for each channel.

Code	Decode	Encode
1	67.0	100.0
2	D023N	D754I
⋮	⋮	⋮
15	D754I	250.3
16	150.7	D023N

7-2. Operation method

1. You can select operator selectable tones/codes from 16 codes as follows to replace the operator selectable tones/codes for each channel. Hold down the SCN key and press the OPT key in channel display mode to enter code selection mode. Select from 1 to 16 with the channel selector. The display shows the following :
KCH-3 : #1 to #16
KCH-4 : CODE1 to CODE16
To return to channel display mode, press the OPT key.
2. To use the tone/code selected from the 16 codes, press the OPT key in channel display mode with that code. The signaling of the channel operates as the selected tone/code, and the "OPT" indicator lights. When you press the OPT key again, the "OPT" indicator goes off, and the signaling of the displayed channel returns to the original condition (the signaling set for each channel by the programming software).
3. The operator selectable tones/codes function can be also assigned to the AUX key using the programming software. In this case, the "AUX" indicator lights.

INSTALLATION

8. Ignition Sense Cable (KCT-18)

The KCT-18 is an optional cable used to implement the ignition function. This function allows you to turn the radio power on and off using the ignition key of the car. You can disable the horn alert function during driving with the ignition key. (To use the horn alert function, the optional KCK-5 (interface unit) and KDD-4 (DTMF decoder) or KDS-8B or KDS-10 (two-tone decoder) are required.

8-1. Modification to switch the power on and off with the ignition key

• When you use the TK-730H and KCH-3 or KCH-4

1. Remove the short plug (P1) from the accessory connector (15-pin : J4) on the rear of the radio.
2. Insert the KCT-18 contact into pin 3 (IGN).
3. Remove the upper half of the radio case.
4. Cut W101 of the control unit (X57-3750 A/3) (Fig. 8-c), and reinstall the upper half of the radio case.

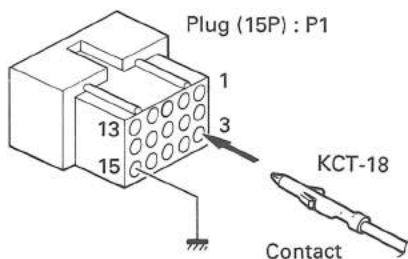

Fig. 8-a

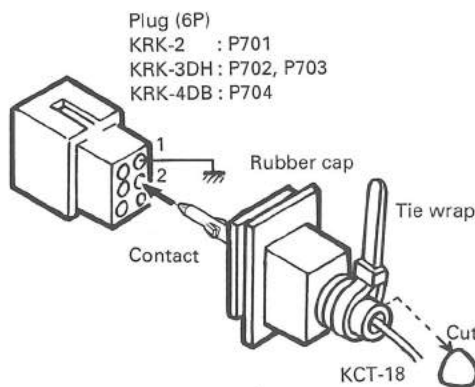

Fig. 8-b

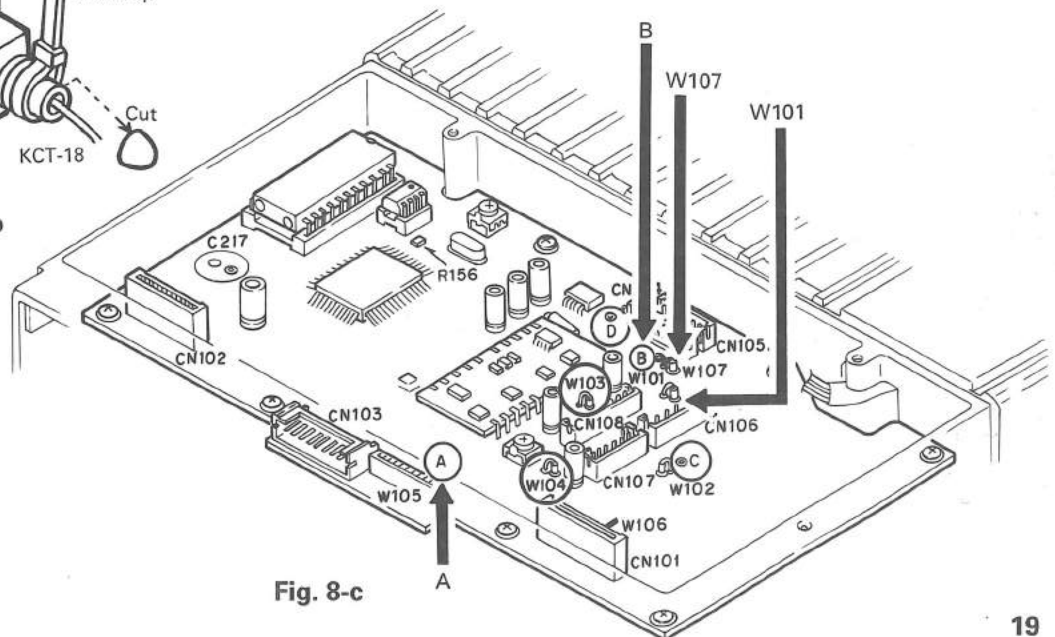

Fig. 8-c

• When you use the remote kit (KRK-2, KRK-3DH, or KRK-4DB)

If you use the accessory connector (15-pin : J4) on the rear panel of the radio, use the same procedure as above.

When you use the KRK-4DB, use the 15-pin accessory connector of radio 1.

If you use the accessory connector (6-pin) on the rear of the control head :

1. Remove the short plug from the accessory connector (6-pin) on the rear panel of the control head.
2. Cut off the end of the rubber cap (accessory), insert the KCT-18 into the cap, and insert it into pin 2 (SPR) of the short plug.
3. Install the short plug and rubber cap on the connector on the rear of the control head, then clamp the bottom of the rubber cap with the supplied tie wrap.
4. Remove the upper half of the radio case.
5. Cut W101 of the control unit (X57-3750 A/3). Insert jumpers into lands A and B, and solder them on the rear of the board. (If you use the KRK-4DB, modify only radio 1.)
6. Install the upper half of the radio case.

Note : If you use the KCT-18 with the KRK-4DB, use the 15-pin plug on the rear of radio 1, and the plug (6-pin) on the rear of the control head. You cannot use the 15-pin accessory connector on the rear of radio 2.

8-2. Horn alert function on/off with the ignition key

Modify as described in 8-1 above. Cut W107, not W101.

INSTALLATION

9. External Speaker (KES-4)

The TK-730H speaker output is as follows :

1. The KCH-3 contains a speaker (5W/8Ω).
2. The KCH-4 does not contain a speaker.
3. The external speaker output from the accessory connector (15-pin) on the rear of the radio is 13W/4Ω. Use external speaker KES-4.
4. If you use a remote kit (KRK-2, KRK-3DH, KRK-4DB), the external speaker output from the accessory connector (6-pin) on the rear of the control head is 5W/4Ω. Use external speaker KSP-1A or KES-4. You can use the KSP-1A only when you short pins 9 and 12 of the accessory connector (15-pin) on the rear of the radio and do not increase the speaker output (see page 22).

Note : The TK-730H does not have a ground because it uses a BTL audio amplifier. Do not connect leads to the ground.

9-1. Connection for the KES-4 with the TK-730H

- **When taking the AF output from the accessory connector (15-pin) on the rear of the radio**

The following tools are required for changing the connector.

Extracting tool

The following extracting tool is recommended :
Molex Inc. Order No. : 11-03-0002

1. Remove the connector with jumper from the external speaker connector on the rear panel of the radio. (Fig. 9-a)

Note : Save the jumper, which is required when the radio is used without the external speaker.

2. Remove the terminals with the jumper from the connector housing holes number 9 and 12 using the extracting tool.

Removing the jumper lead (Fig. 9-b)

- 1) Insert the extracting tool (11-03-0002) into the connector while pushing the jumper lead in the direction of (a).
 - 2) Push the extracting tool into collapse the barbs of the crimp terminal.
 - 3) Pull out the lead while continuing to push the extracting tool in the direction (b).
3. Reinsert the terminal with the black and white stripe lead into hole number 12, and the terminal with the block lead into hole number 6. (fig. 9-c)
 4. Attach the connector to the external speaker connector on the radio.

Note : Relationship between accessory connector (15-pin) connection and speaker output
When pins 9 and 12 are shorted ; The 5W internal speaker is used.

When pins 9 and 12 are open and output is from pins 6 and 12 ; The 20W external speaker (KES-4) is used.

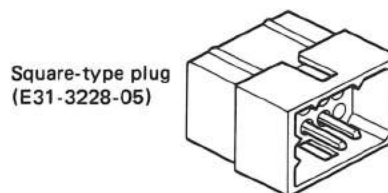

Fig. 9-a

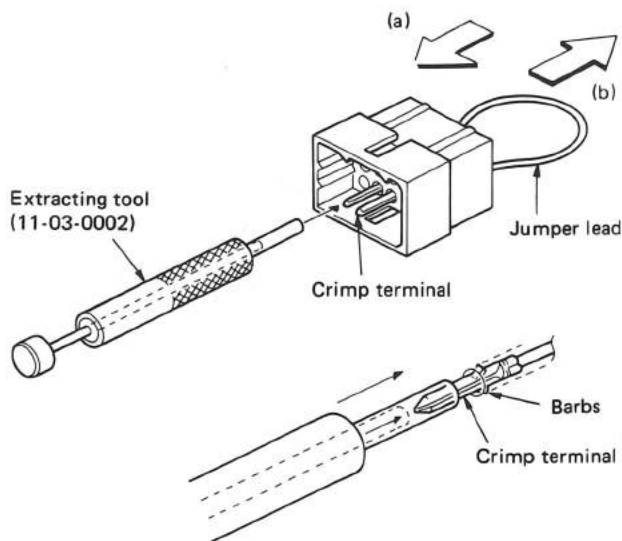

Fig. 9-b

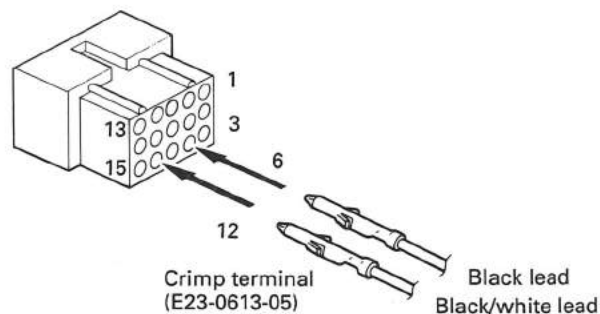

Fig. 9-c

INSTALLATION

9-2. Connection for the KES-4 with the remote kit (KRK-2, KRK-3DH, or KRK-4DB) (When output is from the 6-pin accessory connector on the rear of the control head : remote operation)

• Modification of plug (6-pin)

1. Remove the short plug from the accessory connector (6-pin) on the rear of the control head.
2. Remove the cables from pins 4 and 5 with the extracting tool. (Remove them as described in Section 9-1.)
3. Cut off the end of the rubber cap, insert the KES-4 speaker cable into the cap, and insert it into pins 5 and 6.
4. Install the plug and rubber cap on the accessory connector on the rear of the control head, then clamp the bottom of the rubber cap with the supplied tie wrap.

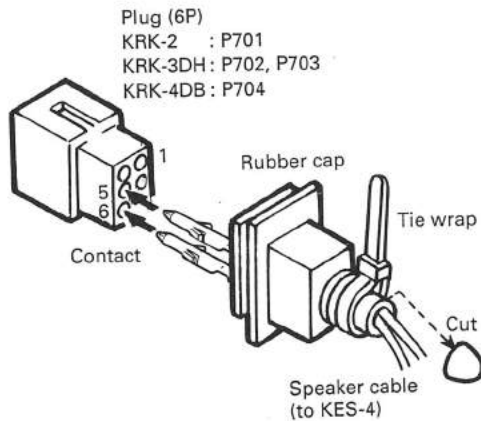

Fig. 10

Notes :

1. Since the output from the accessory connector (6-pin) is 5W, you can use the KSP-1A (speaker).
2. Relationship between accessory connector (6-pin) connection and speaker output
When pins 4 and 5 are shorted ; The 5W internal speaker is used (KCH-3 only).
When pins 4 and 5 are open and output is from pins 5 and 6 ; The 5W external speaker is used.

• Modification of the control unit (X57-3750 A/3)

Modify the radio connected with a remote kit as follows :

Remove the upper half of the case of the radio, and solder (short) W106 of the control unit. If you do not, the control head speaker output will deteriorate. If the radio is restored to the basic model (the remote kit is removed), open W106, otherwise the maximum head speaker input will be exceeded.

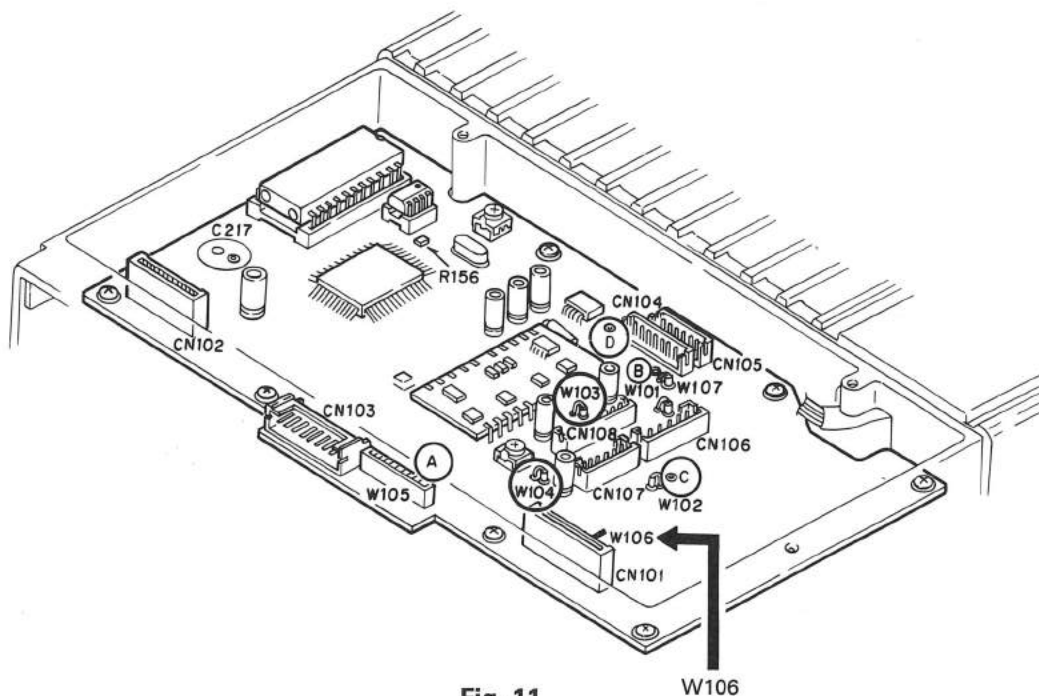

Fig. 11

W106

INSTALLATION

• Modification to increase the control head speaker output (from 5 to 10W)

You can increase the speaker output to 10W by shorting W106 of the control unit as described previously, and soldering W10 of the X46-3110-20 (KRK-2), X46-3090-20 (KRK-3DH), or X46-3100-20 (KRK-4DB) of the control head.

In this case, you cannot use the KCH-3 internal speaker because the maximum input of 5W is exceeded, so use the KES-4.

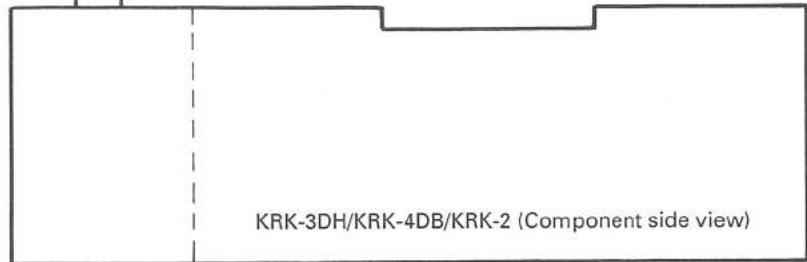
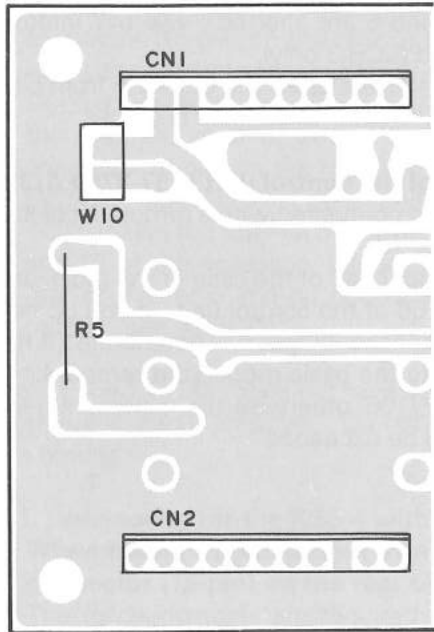

Fig. 12

9-3. Use as public address speaker

1. Remove the short plug (P1) from the 15-pin accessory connector (J4) on the rear of the radio. (Remove the jumpers as described in Section 9-1.)
2. Insert the KES-4 speaker leads into pins 13 and 14 of P1.
3. If you remove jumper shorting pins 9 and 12, the 20W PA (public address) voice signal is output from pins 13 and 14. (Only when the PA or SP switch is on)
4. If you use the radio with pins 9 and 12 shorted, the internal speaker is available (when the KCH-3 is used). The KCH-4 does not contain a speaker.

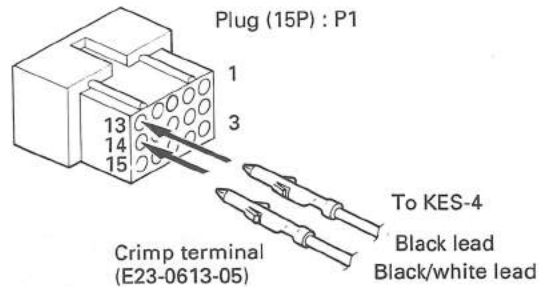

Fig. 13

Note :

Relationship between accessory connector (15-pin) connection and speaker output

When pins 9 and 12 are shorted ; The 5W internal speaker is used (KES-3 only).

When pins 9 and 12 are open and output is from pins 13 and 14 ; The 20W external speaker is used.

INSTALLATION

10. Channel Expansion Kit (KCH-5)

This optional kit increases the number of channels and AN (alphanumeric) channels of the radio.

10-1. System configuration

- *32B : Basic control head (32 ch)
- 99B : Basic control head (99 ch)
- 32A : Basic + Alphanumeric (32 ch)
- 99A : Basic + Alphanumeric (99 ch)
- *32F : Full featured control head (32 ch)
- 160F : Full featured control head (160 ch)
- * : Factory setting

10-2. System modification

• KCH-3 (basic control head) is used

1. 99B (basic control head : 99 channels)
Modify the radio with the basic control head (32 channels) so that it supports a 99-channel display.
1) Remove the upper half of the radio case.
2) Remove IC109 from the control unit (X57-3750 A/3) and install the KCH-5 EEPROM (X24C16PI) by soldering. (Fig. 14)

Note : Install it in the correct direction. Check the mark on the IC (KCH-5), and insert it.

- 3) Remove R156 (R92-0670-05) of the control unit. (Fig. 14)

2. 32A (basic + alphanumeric display : 32 channels)
Modify the radio with the basic control head (32 channels) so that it supports a 32-channel alphanumeric display.

- 1) Install the KCH-5 EEPROM in IC3 of the KCH-3 display unit (X54-3100-20 A/2) by soldering.

Note : Install it in the correct direction. Check the mark on the IC (KCH-5), and insert it. (Fig. 15-a)

- 2) Remove R18 (R92-0670-05) of the display unit. (Fig. 15-a)
3. 99A (basic + alphanumeric display : 99 channels)
Modify the radio with the basic control head (32 channels) so that it supports a 99-channel and alphanumeric display.
1) Install the KCH-5 EEPROM in the control unit by soldering, and remove R156. Remove R18 of the display unit.

• KCH-4 (full-feature control head) is used

1. 160F (Full-featured control head : 160 channels)
Modify the radio with the basic control head (32 channels) so that it supports a 160-channel and alphanumeric display.

- 1) Remove the upper half of the radio case.

- 2) Remove IC109 (X24C04PI) of the control unit (X57-3750 A/3) from the socket, and install the KCH-5 (X24C16PI). (Fig. 14)

Note : Install the IC in the correct direction. Check the mark on the IC (KCH-5), and insert it.

- 3) Remove R156 (R92-0670-05) of the control unit. (Fig. 14)

- 4) Remove IC3 (X24C04PI) of the KCH-4 display unit (X54-3110-20 A/2) from the socket, and install the KCH-5 (X24C16PI). (Fig. 15-b)

Note : Install the IC in the correct direction. Check the mark on the IC (KCH-5), and insert it.

- 5) Remove R33 (R92-0670-05) of the display unit. (Fig. 15-b)

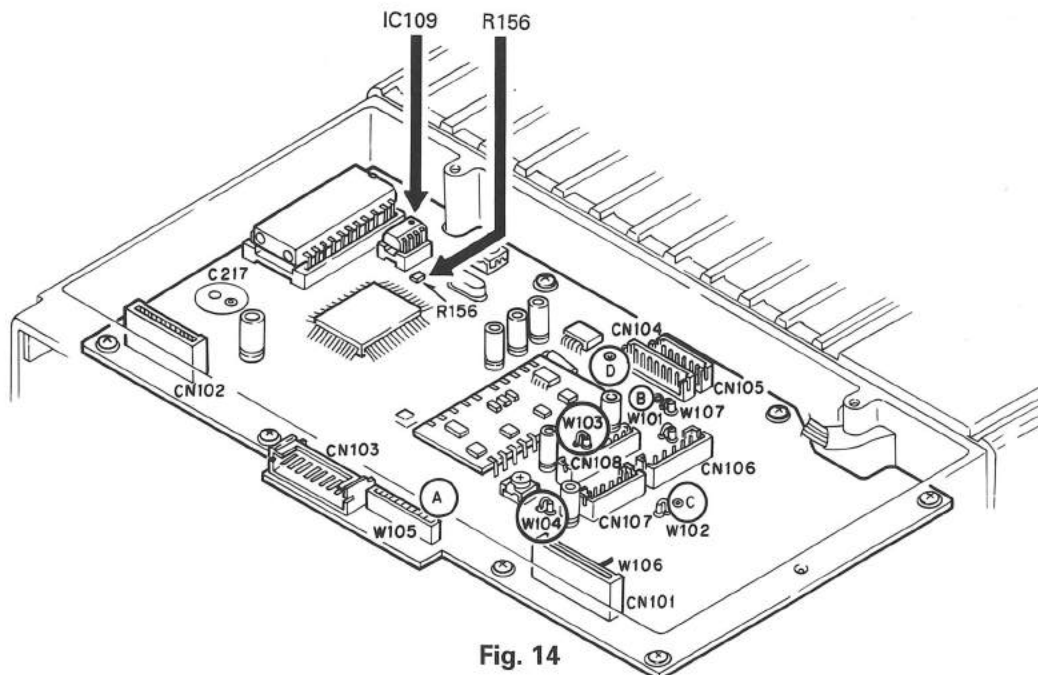

Fig. 14

INSTALLATION

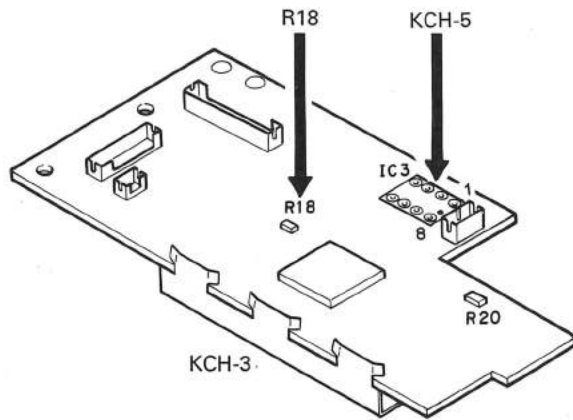

Fig. 15-a

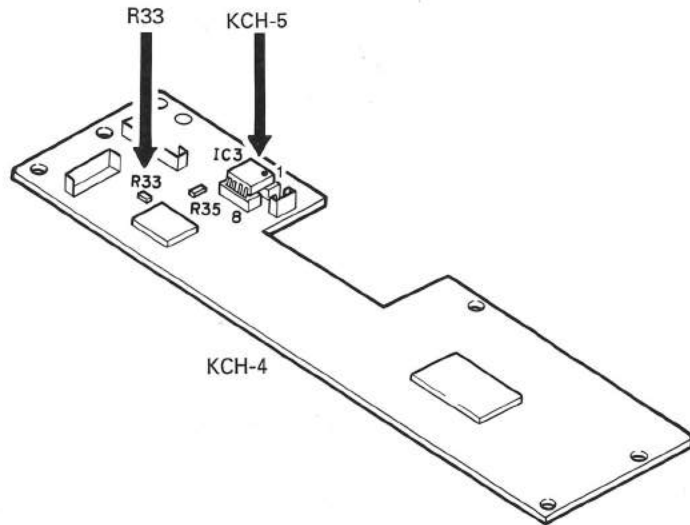

Fig. 15-b

11. KXK-2 (TCXO Kit, 12.8MHz \pm 2ppm)

The KXK-2 is an optional temperature-compensated crystal oscillator. If you replace X302 of the TX-RX unit of the radio with the KXK-2, the transmit frequency stability improves.

11-1. Rating

Item	Rating	Condition
Frequency deviation	$\pm 8 \times 10^{-6}$ or more	Input voltage (VC) : 2Vp-p (1Hz to 3kHz) Power supply voltage : 5 V DC
Temperature characteristics	$\pm 2 \times 10^{-6}$ or less, -30 to +70°C	Power supply voltage : ± 5 V Load : 1k Ω , 10pF Input voltage (VC) : Based on the rated frequency when off
Power variation characteristics	$\pm 0.2 \times 10^{-6}$ or less	5V DC ($\pm 10\%$)

11-2. Radio modification

1. Remove the lower half of the radio case. (Six screws)
 2. Remove the flat cable of CN305 on the TX-RX unit (X57- B/3) from above. Remove coaxial plugs CN301 and CN303, and connector CN304 (1).
 3. Remove the seven screws (2) holding the TX-RX unit, and remove the TX-RX unit.
 4. Remove X302 (L77-1466-05) from the unit with a soldering iron (3).
 5. Insert the KXK-2 into the X302 land from above, solder the four leads (4), and cut them.
- Note :** Install the KXK-2 in the correct direction. When installing it, check the adjusting hole position, as shown in the illustration. You do not need to adjust the frequency because it has been factory adjusted.
6. Install the TX-RX unit in the radio by reversing the order of removal.

INSTALLATION

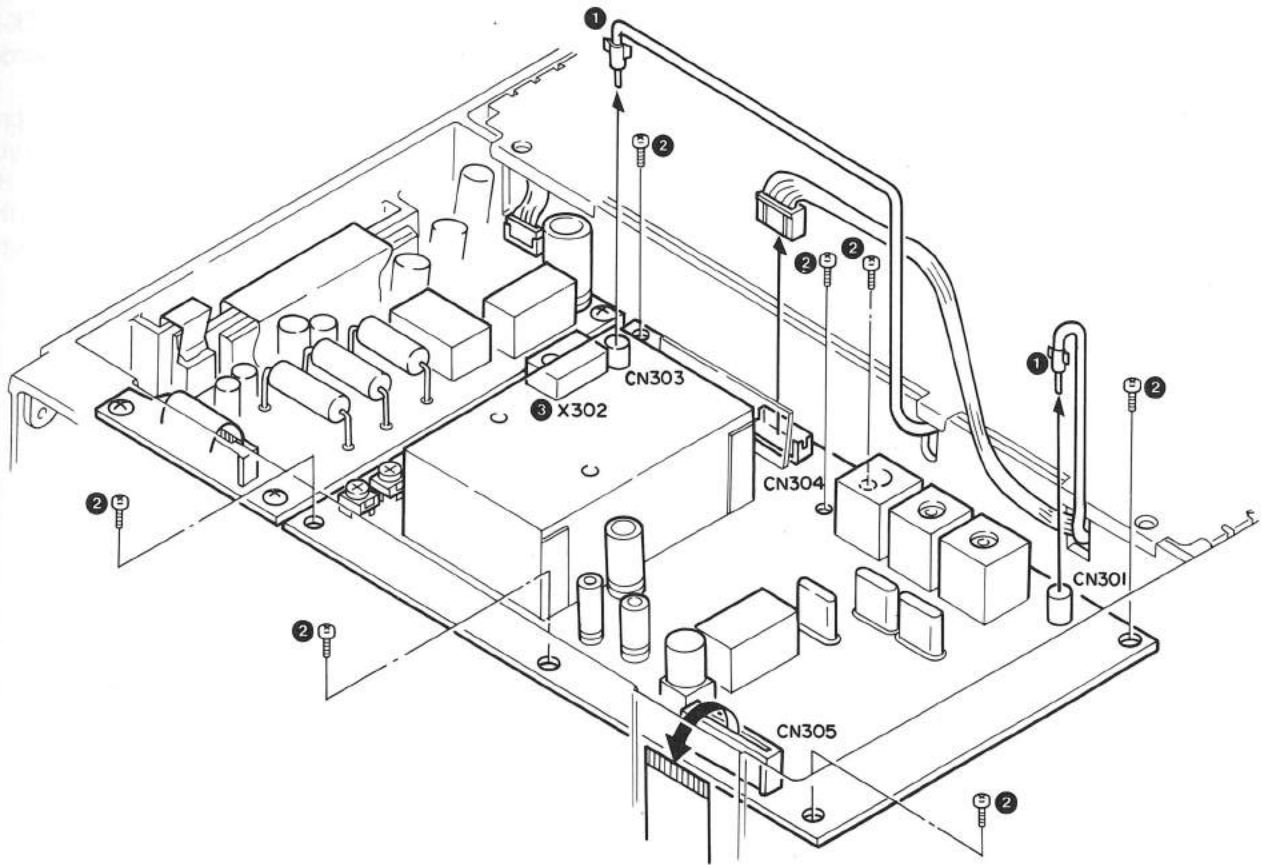

Fig. 16-a

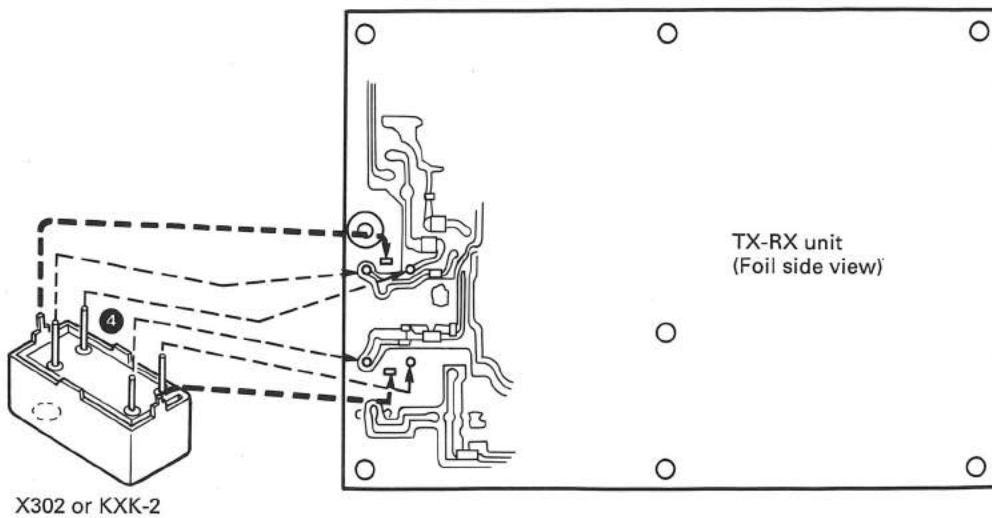

Fig. 16-b

TK-730H(B)

INSTALLATION/DISASSEMBLY FOR REPAIR

12. Horn Alert Function

The horn alert function is available for a transceiver to which the optional KCK-5 (interface kit) and KDD-4 (DTMF decoder), KDS-8B (two-tone decoder), or KDS-10 (two-tone decoder) have been added and for which jumper W107 in the control unit (X57-3750 A/3) has been cut. (For the installation method, see the KCK-5 service manual.)

1. The horn alert function controls external equipment by energizing the relay of the interface unit (KCK-5) for a certain time after the above optional decoder detects matching of the call signal.
2. If you set OTHER SIGNALING to "Y" with the programming software (KPG-7D) for a channel, and you press and release the key set as the H.A key, HA (KCH-3) or \square HORN \square ALERT (KCH-4) appears on the display, and the radio goes into standby. (The microphone must be onhook.)

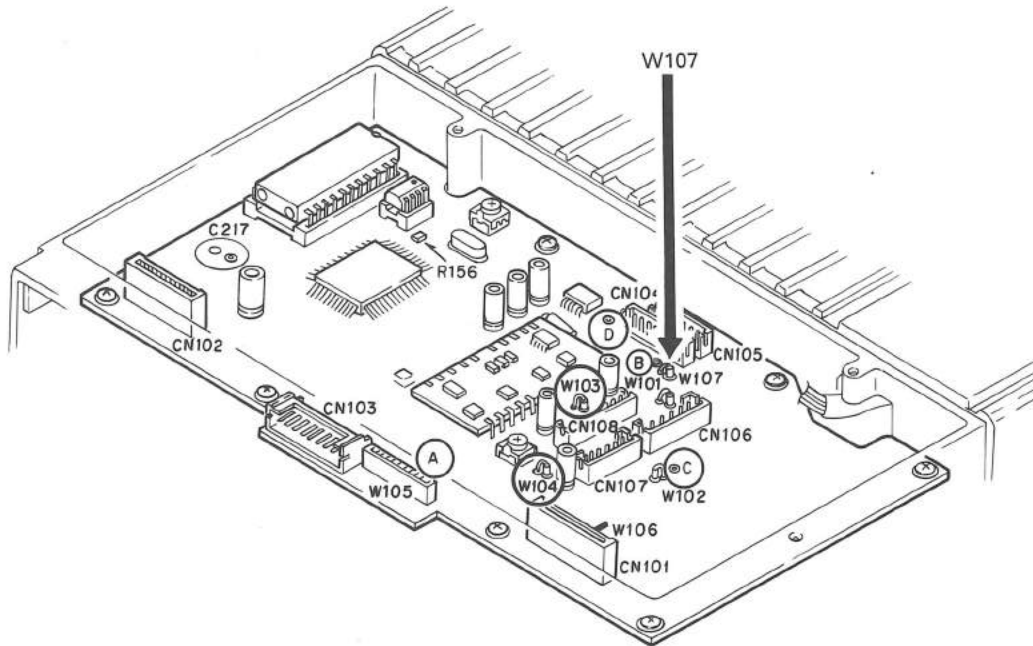

Fig. 17

1. Removing the Case and Shield Cover

1. Remove the ten screws (1), and remove the upper and lower halves of the case. (Remove the four screws holding the upper half and the six screws holding the lower half.)
2. Remove the two screws (2), and remove the shield cover.

2. Removing the TX-RX Unit (X57- B/3)

1. Remove the seven screws (3).
2. Remove the connector (CN304) and coaxial plugs (CN301, CN303) from the final unit, and remove the flat cable (CN305) upwards from the control unit (CN102)

3. Removing the AF Unit (X57- C/3)

1. Remove the four screws (4).
2. With a screwdriver, remove the two leaf springs (5) holding the IC to the frame.
3. Remove the connector (CN502) from the final unit (W1), and remove the flat cable (CN501) upwards from the control unit (CN101).

4. Removing the Final Unit (X45-)

1. Remove the two hexagonal bosses (6).
2. Remove the three screws (7) holding the power module and transistor to the frame.
3. Remove the one screw (8) holding TH1.
4. Remove the four screws (9) holding the final transistor.
5. Remove the two screws (10) holding the lead terminal from ACC connector (6P) on the rear.
6. Remove the 13 screws (11) holding the PC board.
7. Desolder W5 on the antenna connector side.

DISASSEMBLY FOR REPAIR

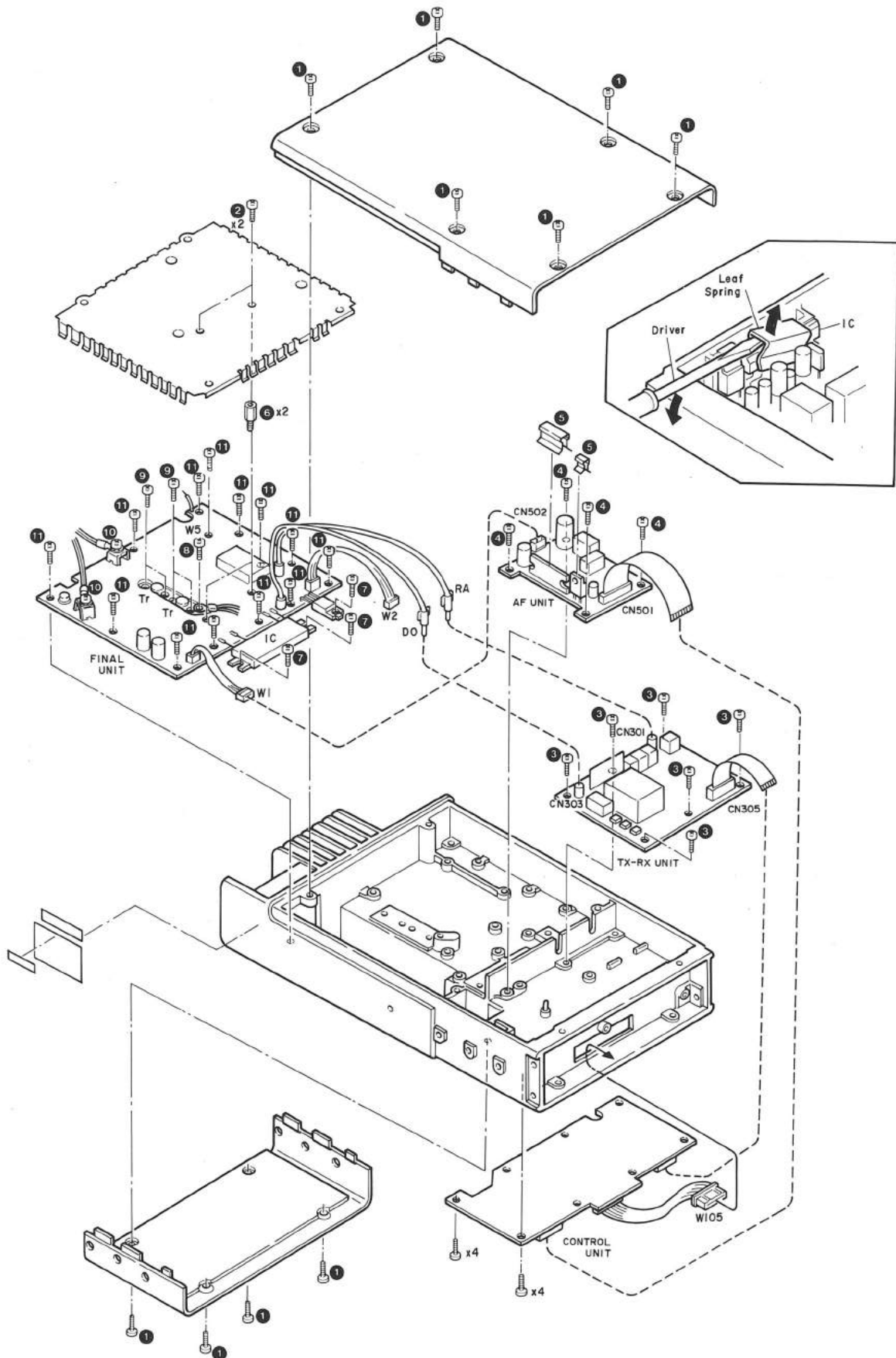

TK-730H(B)

DISASSEMBLY FOR REPAIR

5. Removing the Control Unit (X57- A/3)

1. Remove the eight screws (12).
2. Remove flat cables CN101 and CN102.
3. Remove the two connectors (CN104 and CN105) from ACC connector (15P) on the rear.

6. Removing the Accessory Connector (ACC 15P, ACC 6P) on the Rear

1. Confirm that the screw holding CN3 and the screw holding CN4 of the final unit (X45-) are removed, and that CN104 and CN105 of the control unit (X57- A/3) are disconnected. Remove the four screws on the rear (13).
2. Pull out the connector. (Take the connector terminals out through the opening in the frame.)

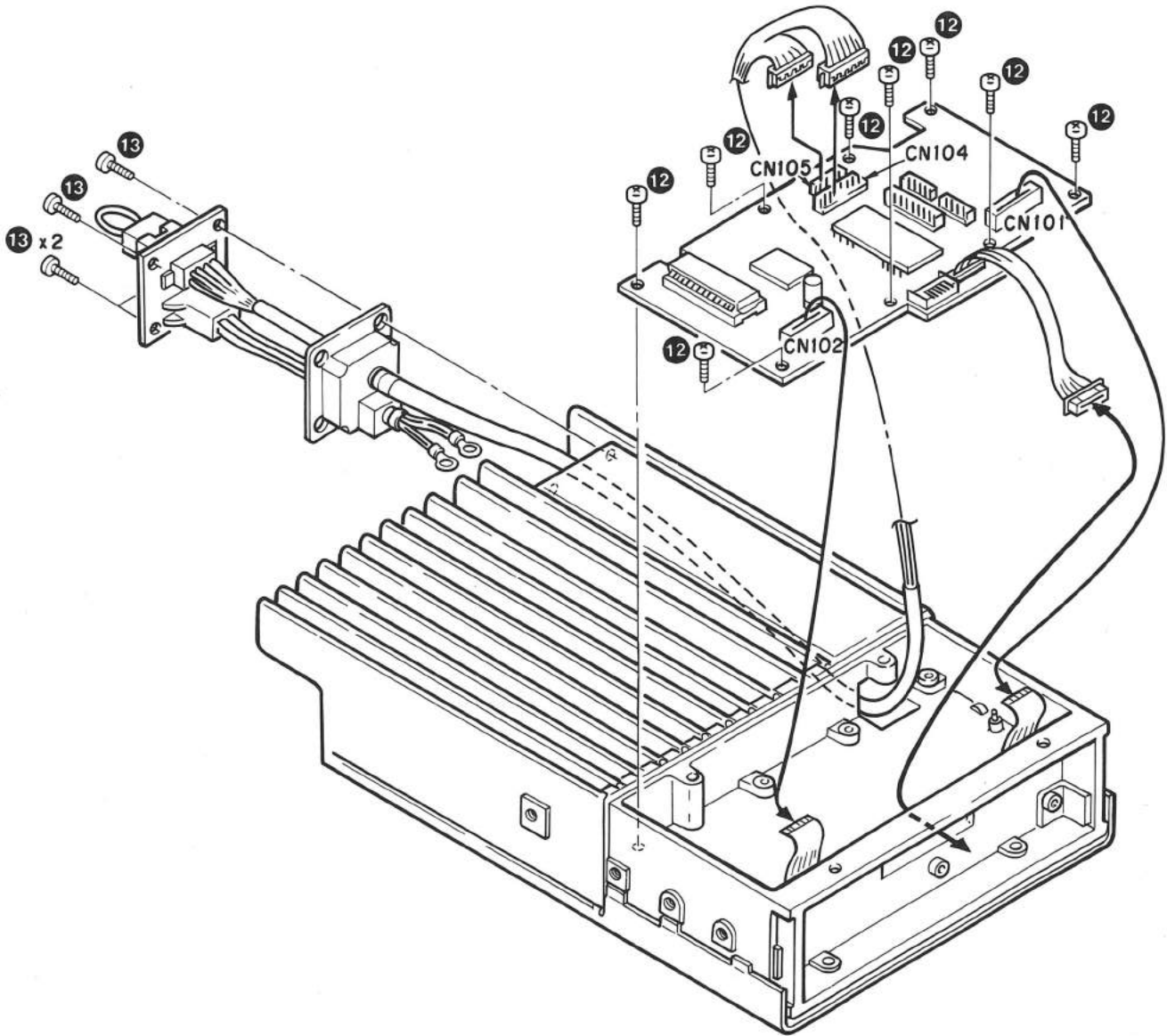

7. D
1. P
2. R
3. D
of
tv
co
4. R
ar
5. R
pa

DISASSEMBLY FOR REPAIR

7. Disassembly of the KCH-3

1. Pull out the VOL and CH knobs (①).
2. Remove the two hexagonal nuts (②).
3. Disconnect the two connectors (CN3 and CN4) (③) of the display unit (X54-3100 A/2), and remove the two screws (④). You can remove the channel encoder (⑩) and display unit.
4. Remove the four screws (⑥) holding the speaker and PC board fitting (⑤).
5. Remove the two screws (⑦), and remove the sub-panel (⑧) and keytop (⑨).

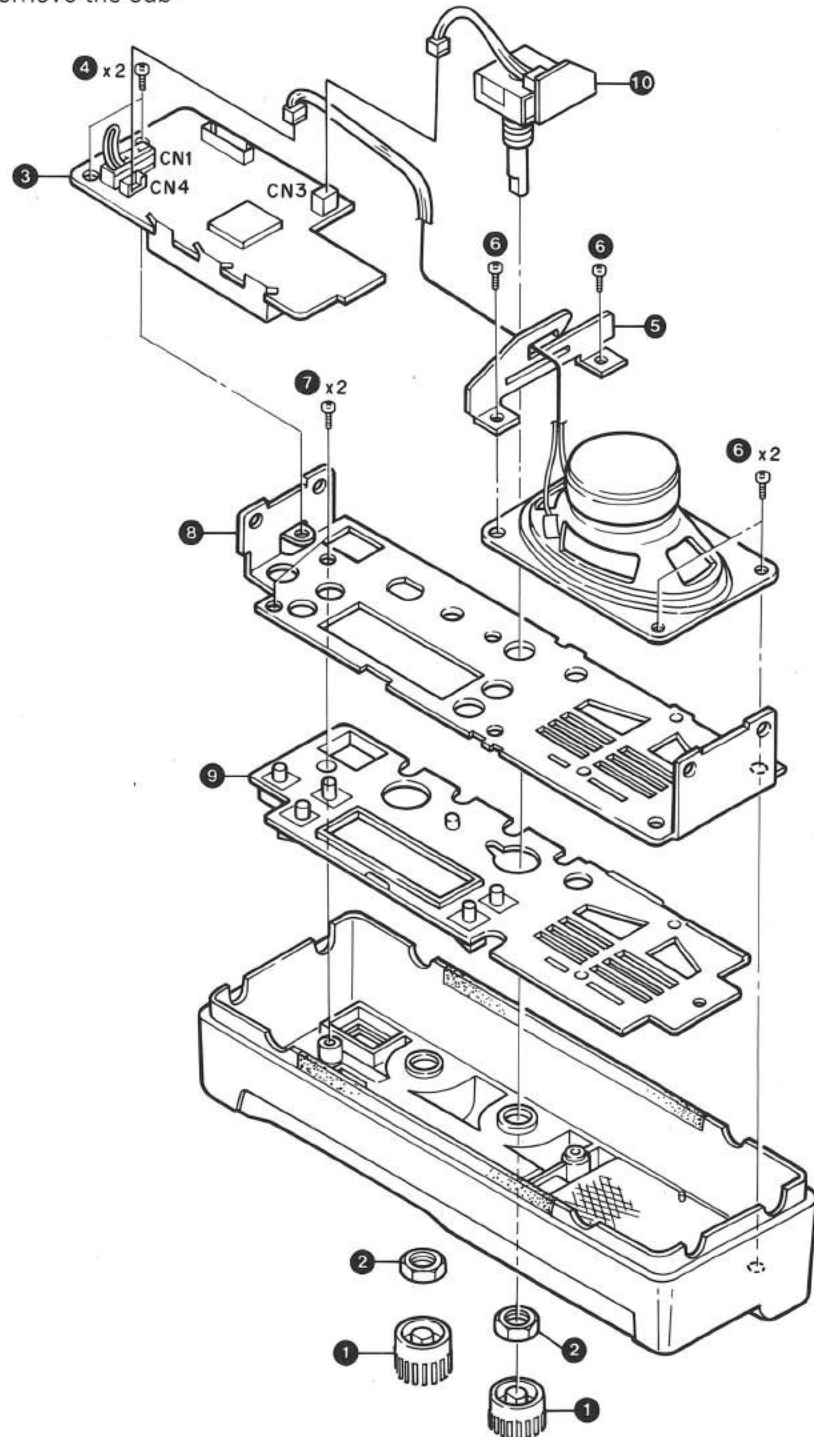

DISASSEMBLY FOR REPAIR

8. Disassembly of the KCH-4

1. Pull out the VOL and CH knobs (1).
2. Remove the two hexagonal nuts (2).
3. Disconnect the connector (CN3) (3) of the display unit (X54-3110 A/2), and remove the five screws (4). You can remove the channel encoder (5) and display unit.
4. Remove the four screws (6), and remove the sub-panel (7) and keytop (8).

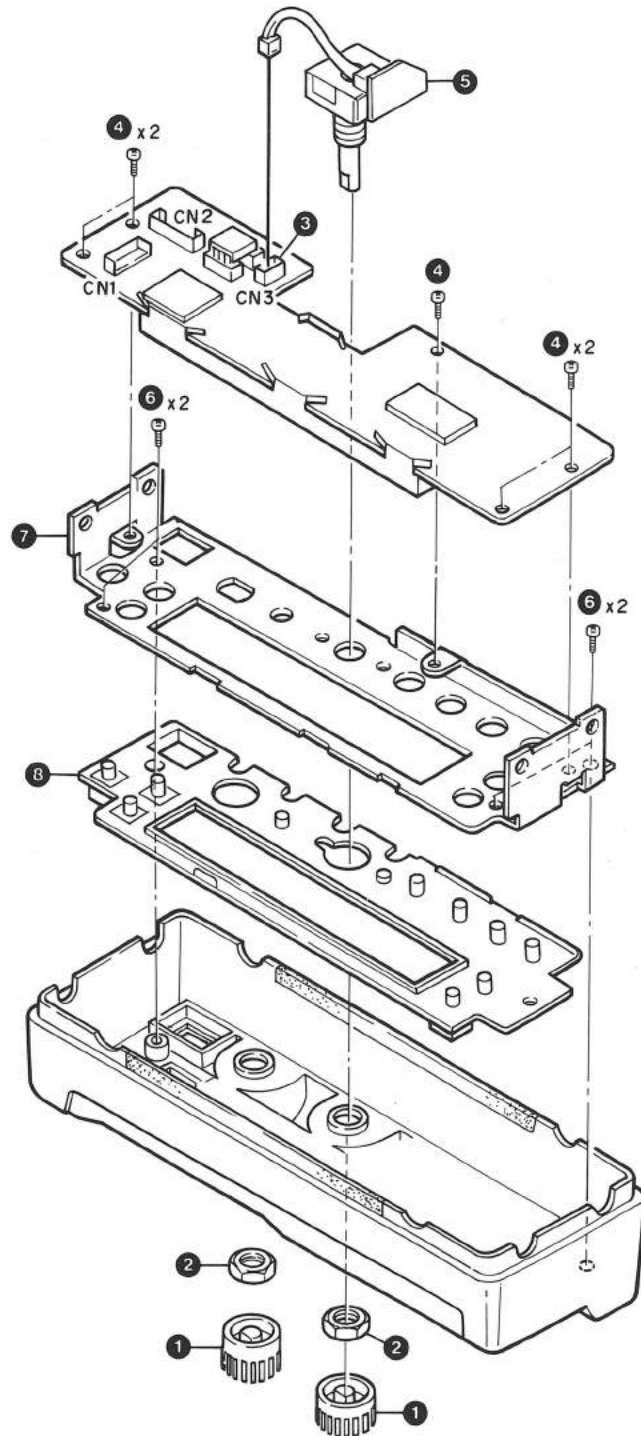

TK-730H(B) TK-730H(B)

BLOCK DIAGRAM

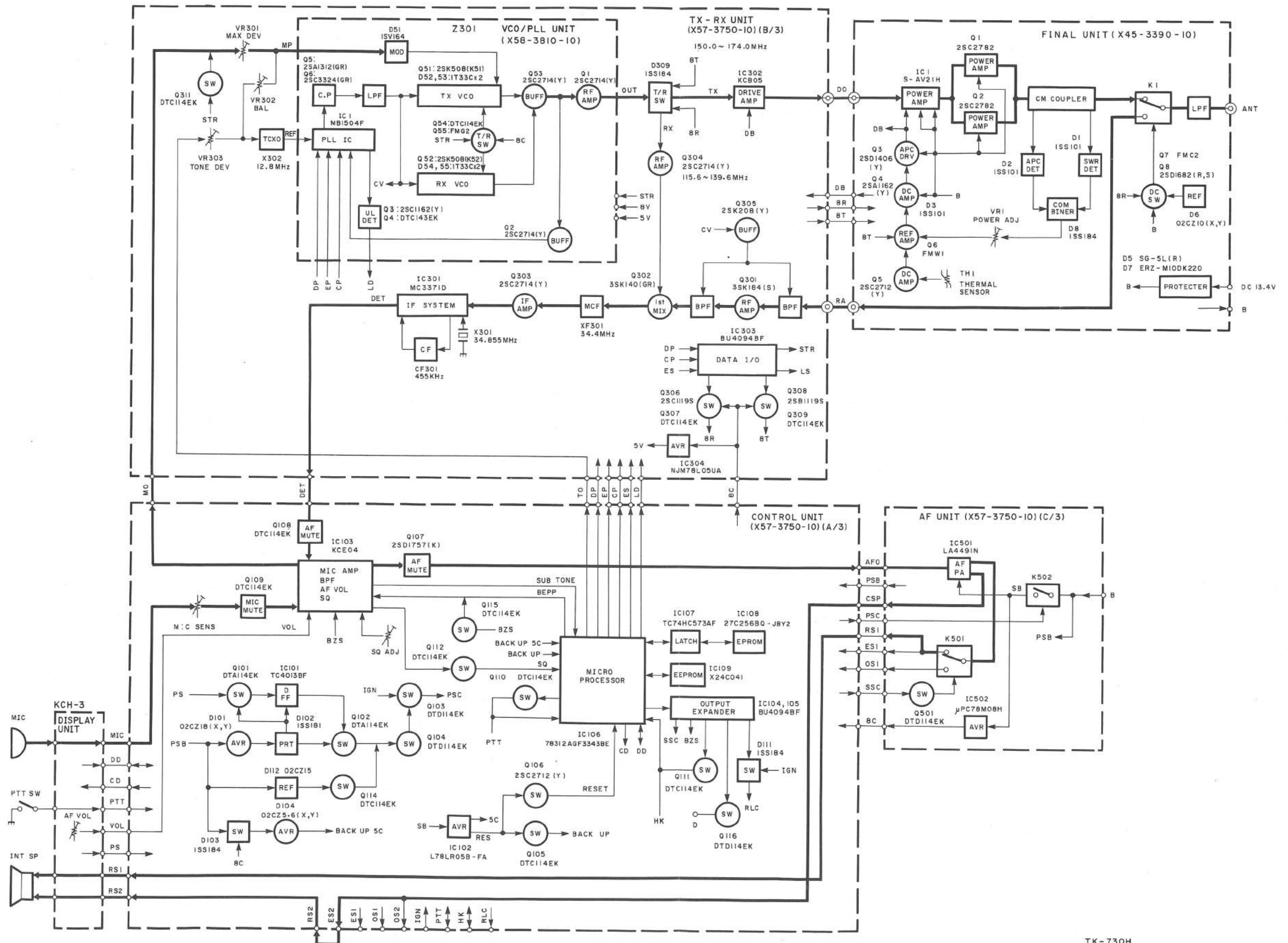

CIRCUIT DESCRIPTION

1. Transmitter Circuit

The audio input from the microphone is attenuated by VR101 and input to MC1 of the audio HIC of IC103 (KCE04). It passes through the active low-pass filter in IC1, limiter D1, the pre-emphasis circuit in IC1, and the active low-pass filter in IC2, which are part of IC103, and is output from the MCO terminal to the CN102 MO terminal. Q109 is used as a microphone mute switch.

The signal from the MO terminal goes to D51 in the VCO unit (Z301), and the VCO is directly modulated. The transmit signal output from the VCO (Z301) passes through switch D309, is amplified by pre-drive hybrid IC IC302, and is applied to drive hybrid IC IC1.

The signal is power amplified by IC1, and the output of IC1 is divided into two signals; these are amplified by Q1 and Q2. The signals are mixed and the resulting signal is fed through transmit/receive switching relay K1 and the 7-pole low-pass filter to the antenna connector.

There is a line for detecting traveling and reflected waves prior to the transmit/receive switching relay. Travelling waves are detected by D1 and fed through the APC control (VR1) to differential amplifiers Q6, which compare the signal level with the reference voltage. The output is amplified by DC amplifier Q4 to control APC DC amplifier Q3. Q3 controls the power supply voltage for IC302 and IC1, keeping the transmitter output constant.

To protect the transmitter power amplifier stages, there are two protection circuits, one protecting against abnormal antenna loading and the other, against overheating. If an abnormal antenna load is connected, the reflected wave level increases. Reflected waves are detected by D2, D3 and the output level is fed to the differential amplifier, leading to the transmitter output power being reduced in the way already described. If an abnormally high temperature is detected by the thermistor (TH1), DC SW Q5 is made to reduce the reference voltage of the differential amplifier. This also leads to the transmitter output power being reduced.

Antenna switching is done by a relay (K1).

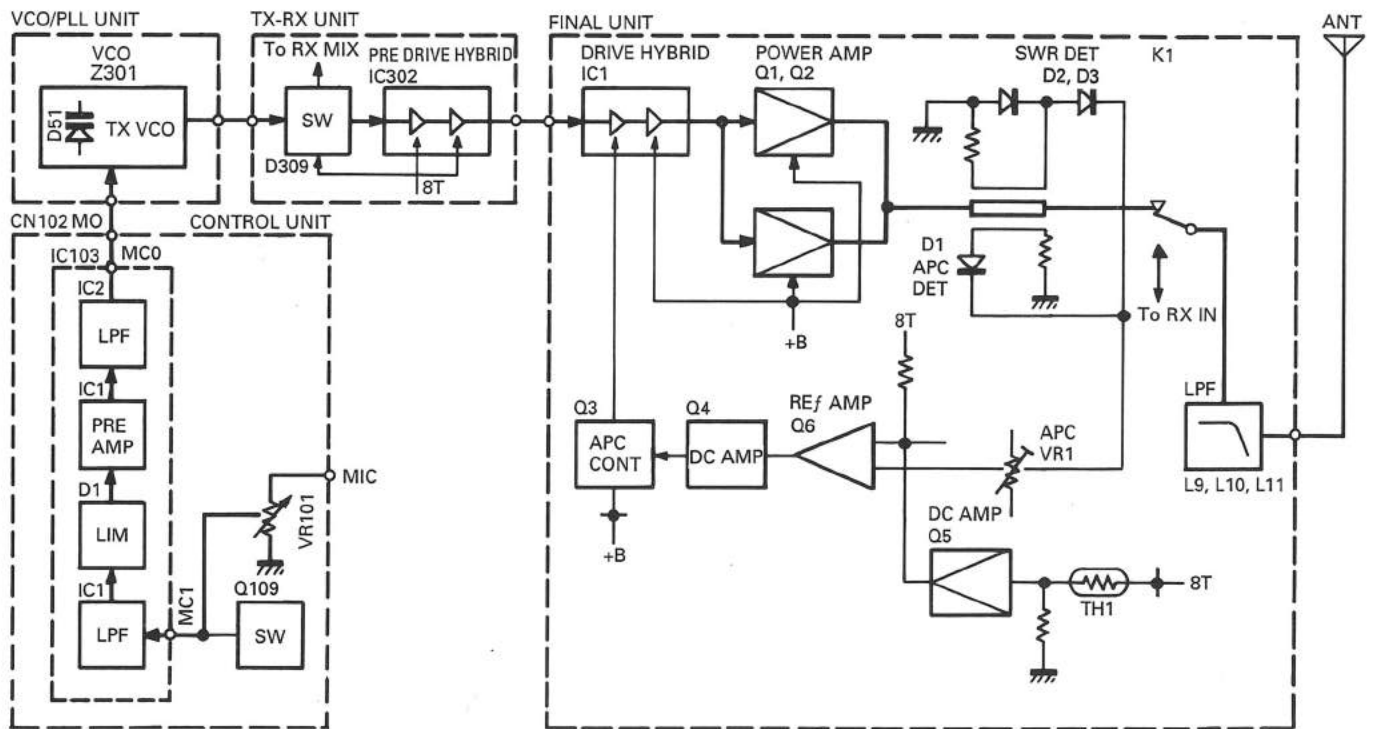

Fig. 1 Transmitter block diagram

CIRCUIT DESCRIPTION

2. Receiver Circuit

Incoming signals from the antenna pass through a low-pass filter in the final unit of the transmitter system, and are switched to the front-end of the receiver system via a receive/transmit switching relay (K1).

The signal are then passed through an antenna matching coil, where the high-frequency components are amplified by a GaAs FET (Q301). The signals are then fed into bandpass filter that uses varactor diode tuning to reject unwanted signal components, and is fed to the 1st mixer.

The 1st mixer uses the GaAs FET (Q302) that are used in the RF stage to obtain better two-signal characteristics. The 1st mixer mixes the signal with the 1st local oscillator frequency (Z301) and converts it to the 1st IF (34.4MHz).

The signal then passes through two monolithic crystal filters (XF301) to remove unnecessary near-by frequency components. The signal from the XF301 is used as the 1st IF signal.

The 1st IF signal is amplified (Q303) and fed into IC301 in the FM IF IC. The IF signal is then mixed with the 2nd local oscillator frequency of 34.855MHz to generate the 2nd IF of 455kHz. The 455kHz signal is then passed through a ceramic filter (CF301) and fed back into IC301 for additional amplification. The output signal from the IC301 is then fed into a power amplifier via the IC103 (KCE04) on the control unit to the speaker.

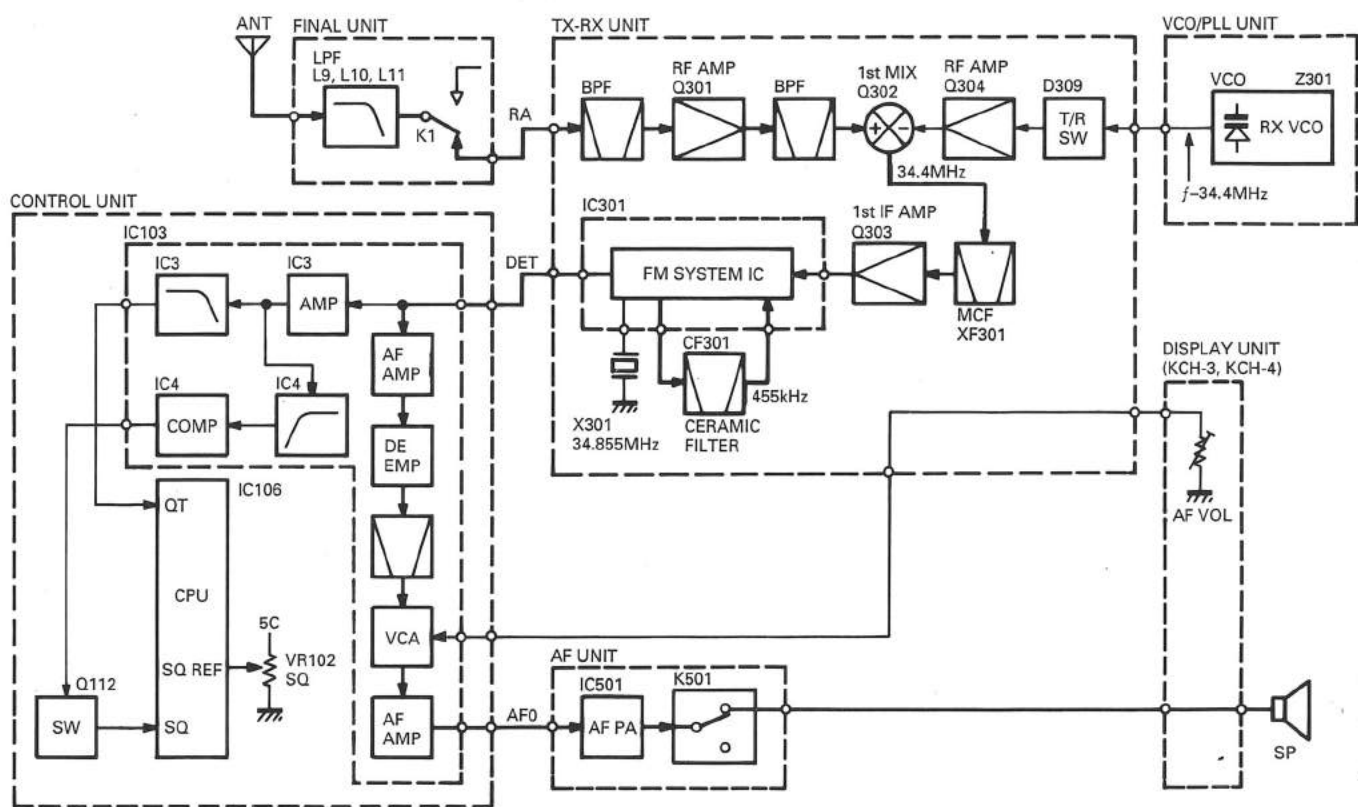

Fig. 2 Receiver block diagram

CIRCUIT DESCRIPTION

Item	Rating
Nominal center frequency	34.4MHz
Pass bandwidth	$\pm 7.5\text{kHz}$ or more at 3dB
Attenuation bandwidth	$\pm 28\text{kHz}$ or less at 40dB
Ripple	1.5dB or less
Insertion loss	3dB or less
Guaranteed attenuation	60dB or more within $\pm 1\text{MHz}$ (Spurious : 40dB or more)
Terminating impedance	800 Ω /1.5pF

Table 1 MCF (L71-0298-05) : TX-RX unit XF301

Item	Rating
Nominal center frequency	455kHz \pm 1kHz
6dB bandwidth	$\pm 6\text{kHz}$ or more (from 455kHz)
50dB bandwidth	$\pm 12\text{kHz}$ or less (from 455kHz)
Ripple (within $\pm 4\text{kHz}$ of 455kHz)	3dB or less
Insertion loss	6dB or less
Guaranteed attenuation (within $\pm 100\text{kHz}$ of 455kHz)	50dB or more
I/O matching impedance	1.5k Ω

Table 2 Ceramic filter (L72-0342-05) : TX-RX unit CF301

3. Squelch Circuit

3-1. Squelch

The signal from the detector is input to the IC103 audio HIC. It is amplified by IC3, and passes through IC4 (high-pass filter), and pulses are output by IC4 (comparator). The pulse level is shifted by Q112, and is input to the pulse count port of IC106 (CPU). The CPU compares the number of pulses with the voltage of the A/D conversion port of the SQREF to detect squelch.

3-2. QT/DQT

The signal from the detector is input to the IC103 audio HIC. It is amplified by IC3 (1/2), and only the signal components below 300 Hz are output from IC103 by IC3 2/2 (low-pass filter). This signal is input to the analog input port (QT) of IC106 (CPU), and is digitized by the CPU. Digital signal processing is performed by the digital filter, and QT/DQT is detected.

4. Audio Circuit

The AF unit consists of IC501 (audio power amplifier), K502 (power on/off relay), K501 (speaker switching relay), and IC502 (8V AVR).

The audio signal output from IC103 of the control unit passes through the AFO terminal, is amplified by power amplifier IC501 to the rated output, passes through K501, and is output from the RS1 terminal to drive the speaker.

Power on/off relay K502 is operated by PSC (low at power on) from the control unit to turn the transceiver power on and off.

The 13.4V DC voltage is regulated to 8V by the 8V AVR (IC502).

Speaker output switching relay K501 changes the signal output destination when Q501 is turned on by SSC (normally low). When public address output is performed or a receive signal is output to the public address speaker (the PA or SP key is on), SSC goes high, and is output from the OS1 terminal.

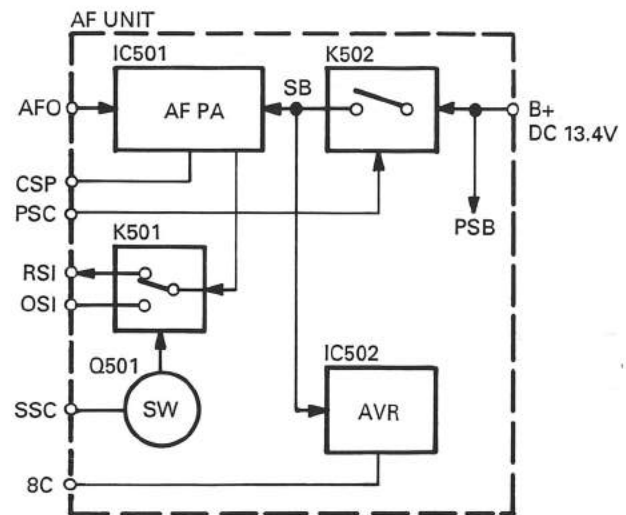

Fig. 3 Audio block diagram

CIRCUIT DESCRIPTION

5. VCO/PLL Unit (Z301)

The PLL generates the transmit signal and the first local oscillator receive signal. The RF signal generated by Q51 (TX) or Q52 (RX) in the VCO unit is amplified by Q53 and Q1 (PLL unit), and the resulting signal is output to the TX-RX unit. TX and RX Q51 and Q52 are switched by turning the source line for Q51 and Q52 on and off. This is done by Q54 and Q55 using the control signal (STR) generated by the serial-to-parallel converter in the TX-RX unit. The RF signal passes through Q53 of the VCO unit and amplifier Q2, and is input to IC1 (PLL IC : MB1504PF). The 12.8MHz PLL reference signal generated by the TCXO (X302) in the TX-RX unit is also input to IC1.

Both signals are divided according to the division data from the control unit to produce a 5kHz signal. The phases are compared, and a phase difference signal is output and passes through Q5 and Q6 (charge pump) and the low-pass filter of the lug lead to produce the control voltage for Q51/Q52 (VCO). This voltage is applied to D52 and D53 (TX) or D54 and D55 (RX) in the VCO unit to control the frequency. If the PLL is unlocked, the IC1 lock detect signal (LD) is converted to a DC signal by Q3 and Q4, and is sent to the microcomputer (IC106) of the control unit. The microcomputer determines that the PLL has been unlocked, and stops signal transmission. It outputs a beep as a warning.

The modulation signal (MP) passing through the VR in the TX-RX unit goes to D51, which is connected to Q51 of the VCO in the VCO unit, and the VCO is directly modulated.

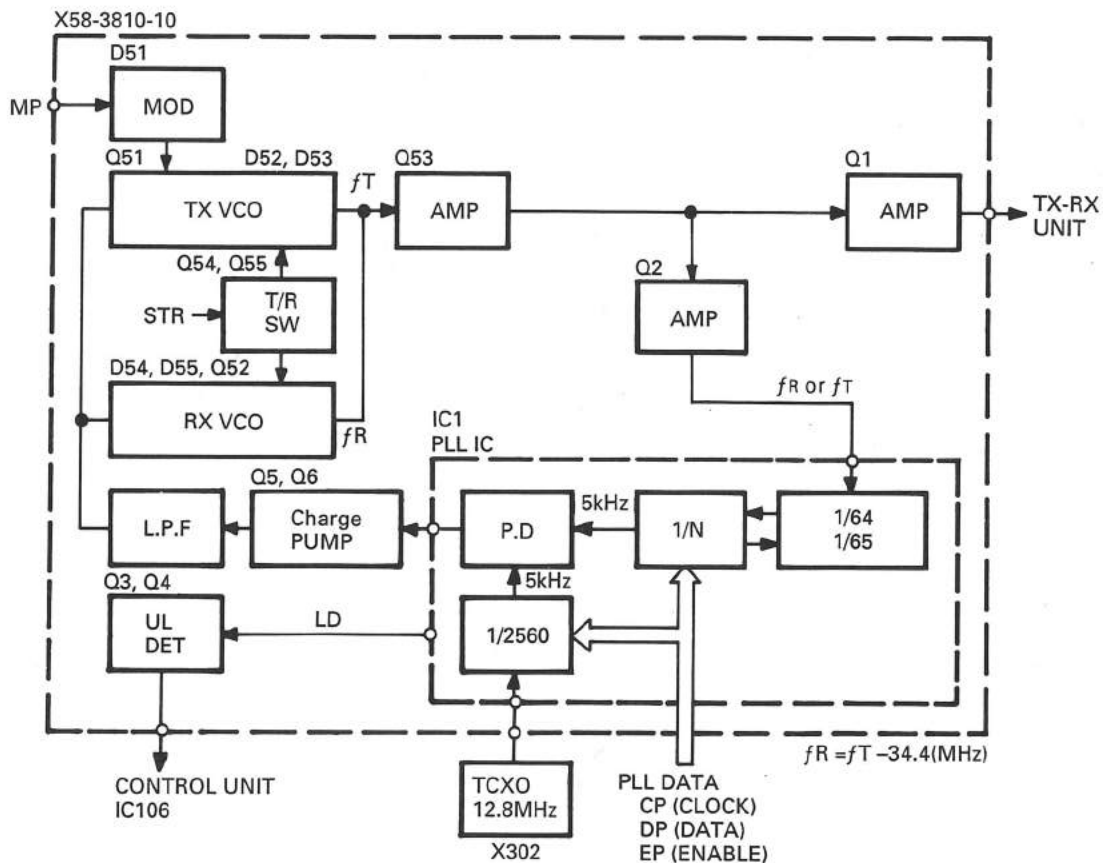

Fig. 4 VCO/PLL block diagram

CIRCUIT DESCRIPTION

6. Control Circuit

6-1. CPU backup and reset

When the CPU is backed up (8C=0V, SB=0V), the PSB voltage passes through a diode OR switch (D103), and is made into a constant voltage of 5V (AVR) by a zener diode (D104) to supply power to the VDD pin of the CPU (IC106). Q105 and Q106 are off, and Reset and NMI (backup interrupt) are high (5V).

When the power switch is turned on, 8C and SB go high. SB is supplied to IC102, and when the output voltage becomes 4.8V, reset delay capacitor C113 is charged. When charging ends, a high signal is output to the IC106 Reset pin.

Q105 turns on and NMI goes low. Q106 is turned on momentarily by reverse polarity diode D106 and pulse generation capacitor C113, and the CPU Reset pin goes low, resetting the CPU.

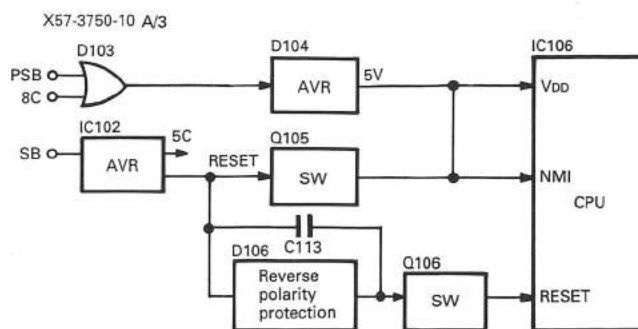

Fig. 5 CPU backup and reset

6-2. Peripheral circuits of the CPU

The transceiver system and channel data is stored in IC109. The PTT and HOOK signals are converted to serial data and sent to the CPU (IC106) from the display unit (KCH-3 or KCH-4). The serial data signal output

from the CPU is sent to the display unit, and data is displayed on the LCD by the LCD driver.

Q110 and Q111 are switching transistors that turn the CPU output on and off.

IC104 and IC105 are used as IC106 expansion ports.

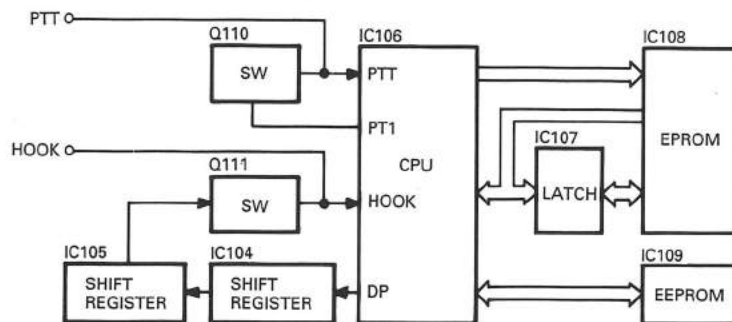

Fig. 6 Peripheral circuit of the CPU

6-3. Transceiver power supply relay (K502: AF unit) control circuit

The voltage is always applied from PSB. The voltage is used to protect IC101 (D/FF) by D101. Pulses from which chattering has been eliminated by Q101 are input to the IC101 clock line. These clock pulses reverse the output. The reversed output drives Q104

via Q102. Since Q103 ANDs Q104, relay K502 cannot be activated unless a voltage is applied to IGN.

If zener diode D112 is connected to PSB, and 24V is supplied to the radio by mistake, Q114 turns on, Q104 turns off, and PSC goes high; The power is forced to be turned off.

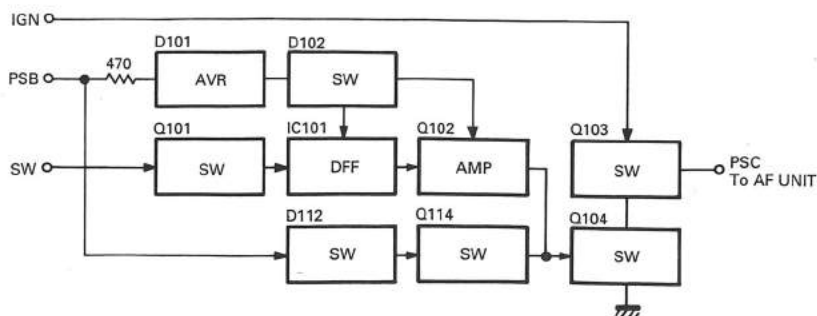

Fig. 7 Transceiver power supply relay control circuit

CIRCUIT DESCRIPTION

7. Display Unit

The optional display unit (front panel unit) for the TK-730H comes in two models : KCH-3 and KCH-4.

7-1. KCH-3

This display unit consists of a CPU (IC1) containing the LCD driver, a reset AVR (IC2), and other components.

• Encoder

Channels are changed by the rotary encoder (ENC). The up/down pulses from the rotary encoder enter the CPU (IC1) by interrupt processing by D5 (diode OR), are converted to a serial data signal, and are sent to the control unit.

• Power supply

Power is supplied to the CPU and backlight lamp (D6, LED assembly) by converting SB from the control unit to 5V by IC2. The CPU (IC1) is reset by the reset output from IC2 when the power is switched on.

• CPU (containing LCD driver)

The on/off signals of keys other than the power switch, and the PTT and HOOK signals, are converted to serial data and sent to the control unit. Data is displayed on the 13-segment, 2-digit LCD by the built-in LCD driver using the serial data signal from the control unit.

• LED (LCD backlight) on/off

When the AUX key is turned on, Q1 turns on, Q2 turns off, and the LED is turned off by the output from the CPU (IC1). Q1 turns the AUX output on and off if the AUX key is not used to turn the LED on and off.

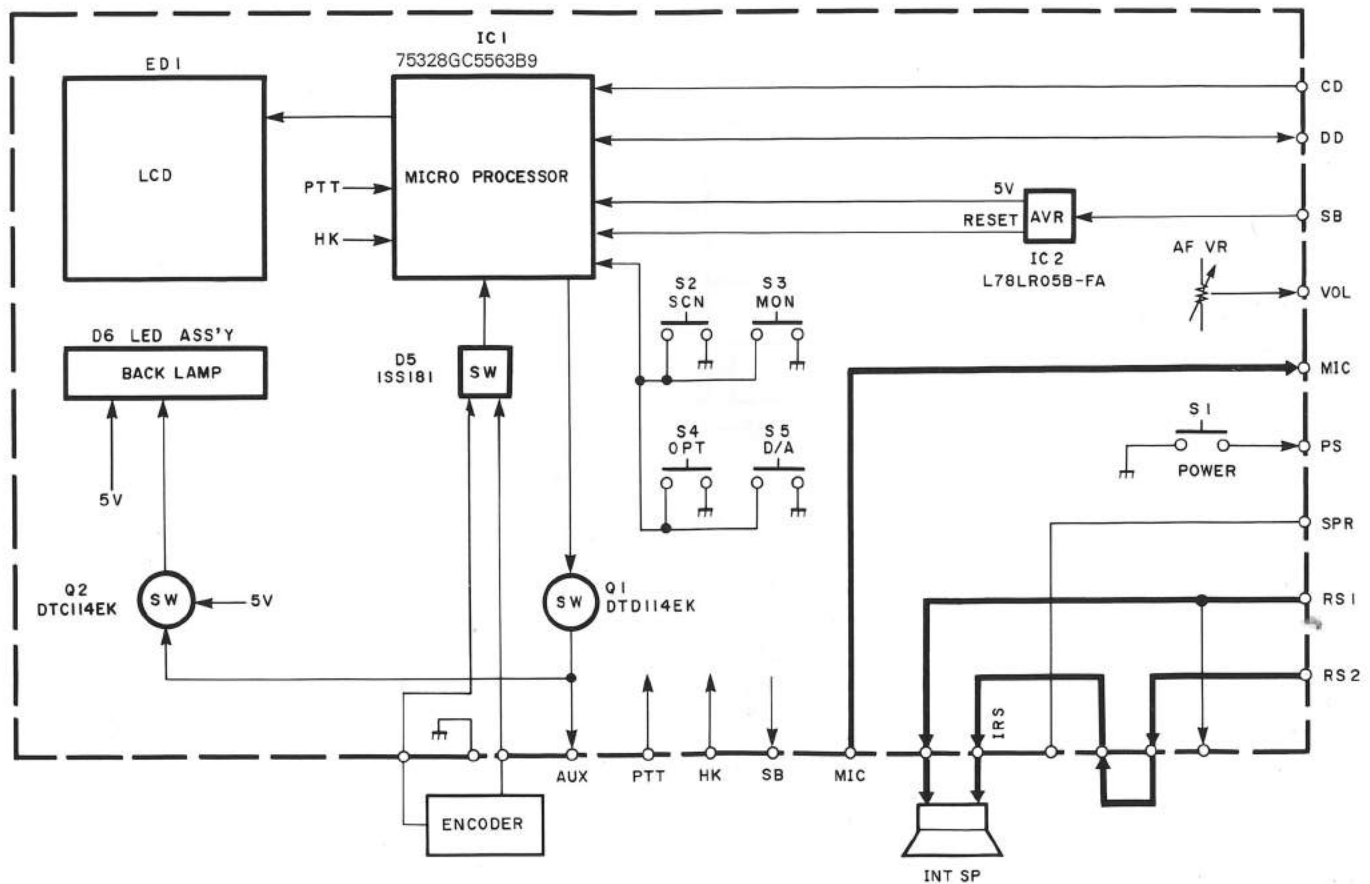

Fig. 8 KCH-3 block diagram

CIRCUIT DESCRIPTION

7-2. KCH-4

This display unit (front panel unit) consists of a CPU (IC1) containing the LCD driver, a reset AVR (IC2), an EEPROM (IC3), an LCD driver (IC4), and other components.

• Encoder

Channels are changed by the rotary encoder (ENC). The up/down pulses from the rotary encoder enter the CPU (IC1) by interrupt processing by D5 (diode OR), are converted to a serial data signal, and are sent to the control unit.

• Power supply

Power is supplied to the CPU (IC1) and backlight lamp (D7, LED assembly) by converting SB from the control unit to 5V by IC2. The CPU (IC1) is reset by the reset output from IC2 when the power is switched on.

• CPU (containing LCD driver)

The on/off signals of keys other than the power switch, and the PTT and HOOK signals, are converted to serial data signals and sent to the control unit. The display data stored in IC3 is displayed on the 13-segment, 12-digit LCD by the built-in LCD driver using the serial data signal from the control unit.

• LED (LCD backlight) on/off

When the AUX key is turned on, Q1 turns on; Q3, which supplies SB to Q2 and D6 of the LED constant-voltage circuit, outputs 0V; and the LED goes off. Q1 turns the AUX output on and off if the AUX key is not used to turn the LED on and off.

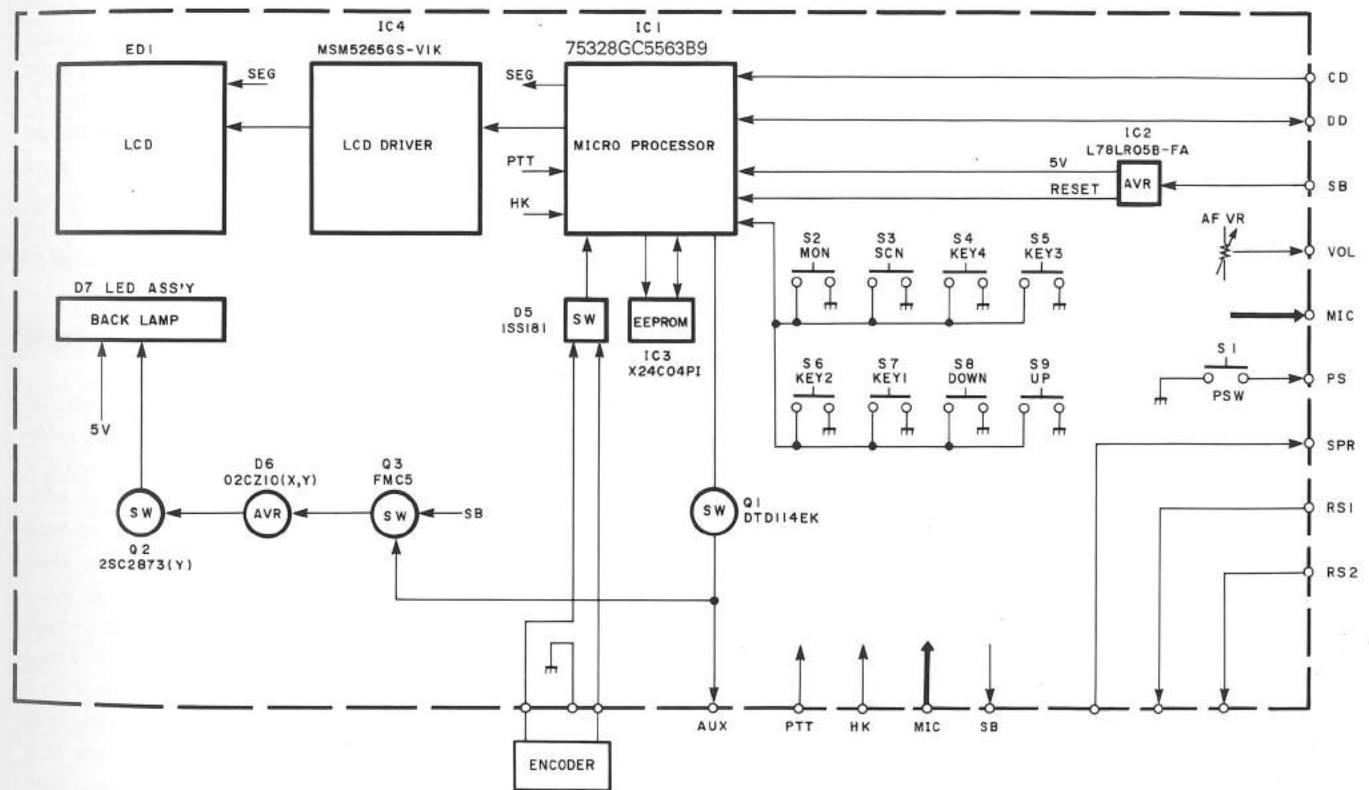

Fig. 9 KCH-4 block diagram

HIC : KCE04 (Control Unit IC103)

• Analog and peripheral switches

Function	CPU control signal								
	VS	DS	BZS	MS	Q107	Q108	Q109	W103	W104
Audio output	○	○	●	●	●	●	○	○	○
Microphone input	●	●	●	●	●	●	●	○	○
Public address	○	●	●	○	●	○	●	○	○
Inter communication (H1 → H2)	●	●	●	○	●	○	●	○	○
Beep output (H1)	●	●	○	●	●	○	●	○	○
Voice scramble (RX)	○	○	●	●	●	●	○	●	●
Voice scramble (TX)	●	●	●	●	○	○	●	●	●

○ : ON, ● : OFF

• Block diagram

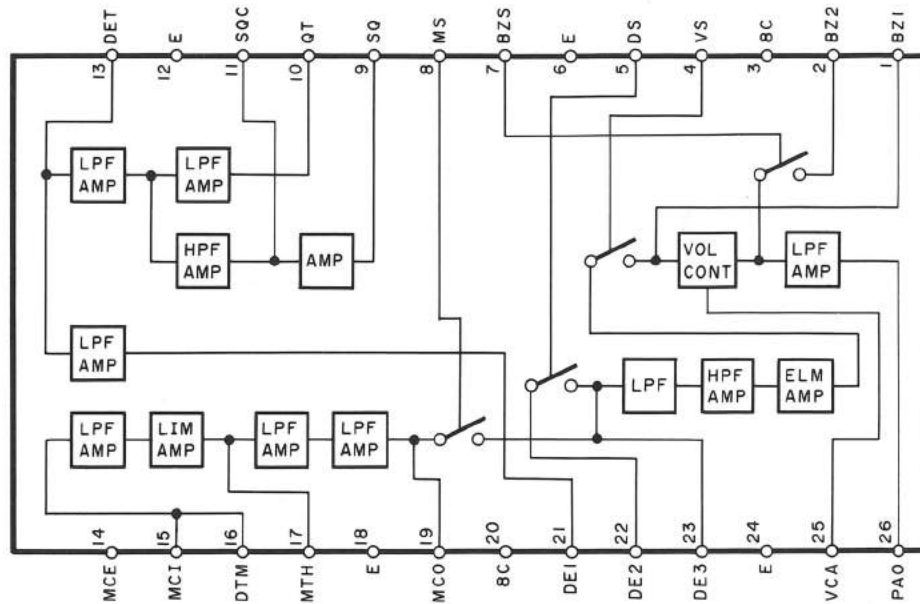

Audio Power Amplifier : LA4491N (AF Unit IC501)

• Terminal connection diagram

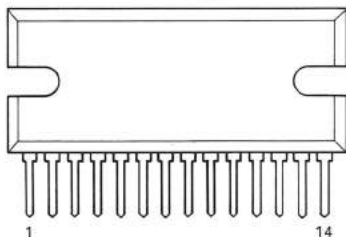

• Electrical characteristics

Item	Symbol	Condition	Rating			Unit
			MIN	TYP	MAX	
DC current	I_{CC}	$V_{in} = 0$	40	80	160	mA
Output power	P_o	T.H.D. = 10%	16	19	-	W
Distortion	T.H.D.	$P_o = 1W$	-	0.06	0.3	%
Voltage gain	V_g		38	40	42	dB
Noise output voltage	V_{NO}	$R_G = 10k\Omega$	-	160	320	μV

SEMICONDUCTOR DATA

EEPROM : X24C16PI (Channel Expansion Kit KCH-5 : Option)

• Terminal description

No.	Name	Description
1	A0	Address inputs
2	A1	The A0, A1 and A2 inputs are unused by the X24C16PI, however, they must be tied to Vss to insure proper device operation.
3	A2	
4	Vss	Vss
5	SDA	Serial data SDA is a bidirectional pin used to transfer data into and out of the device. It is an open drain output and may be wire-ORed with any number of open drain or open collector outputs.
6	SCL	Serial clock The SCL input is used to clock all data into and out of the device.
7	TEST	Test input → to Vss
8	Vcc	Vcc

• Terminal connection diagram

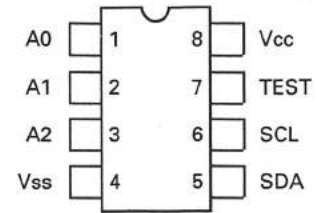
• Operating characteristics $T_a = -40^{\circ}\text{C}$ to $+85^{\circ}\text{C}$, $V_{cc} = +5\text{V} \pm 10\%$, unless otherwise specified.

Item	Symbol	Condition	Rating			Unit
			Min	Typ *1	Max	
Power supply current	I_{CC}	$f_{SCL} = 100\text{kHz}$	—	2.0	3.0	mA
Standby current *2	I_{SB}	$V_{IN} = \text{GND or } V_{CC}$	—	60	100	μA
Input Leakage current	I_{LI}	$V_{IN} = \text{GND to } V_{CC}$	—	0.1	10	μA
Output leakage current	I_{LO}	$V_{OUT} = \text{GND to } V_{CC}$	—	0.1	10	μA
Input low voltage	V_{IL}		-1.0	—	$V_{CC} \times 0.3$	V
Input high voltage	V_{IH}		$V_{CC} \times 0.7$	—	$V_{CC} + 0.5$	V
Output low voltage	V_{OL}	$I_{OL} = 3\text{mA}$	—	—	0.4	V

*1 : Typical values are for $T_a = 25^{\circ}\text{C}$ and nominal supply voltage.

*2 : SDA and SCL require pull up resistor.

• Read & write cycle limits $T_a = -40^{\circ}\text{C}$ to $+85^{\circ}\text{C}$, $V_{cc} = +5\text{V} \pm 10\%$, unless otherwise specified.

Item	Symbol	Min	Max	Unit
SCL clock frequency	f_{SCL}	0	100	kHz
Noise suppression time constant at SCL, SDA inputs	T_I	—	100	ns
SCL low to SDA data out valid	t_{AA}	0.3	3.5	μs
Time the bus must be free before a new transmission can start	t_{BUF}	4.7	—	μs
Start condition hold time	$t_{HD:STA}$	4.0	—	μs
Clock low period	t_{LOW}	4.7	—	μs
Clock high period	t_{HIGH}	4.0	—	μs
Start condition setup time (for a repeated start condition)	$t_{SU:STA}$	4.7	—	μs
Data in hold time	$t_{HD:DAT}$	0	—	μs
Data in setup time	$t_{SU:DAT}$	250	—	ns
SDA and SCL rise time	t_R	—	1	μs
SDA and SCL fall time	t_F	—	300	ns
Stop condition setup time	$t_{SU:STO}$	4.7	—	μs
Data out hold time	t_{DH}	300	—	ns

• Bus timing

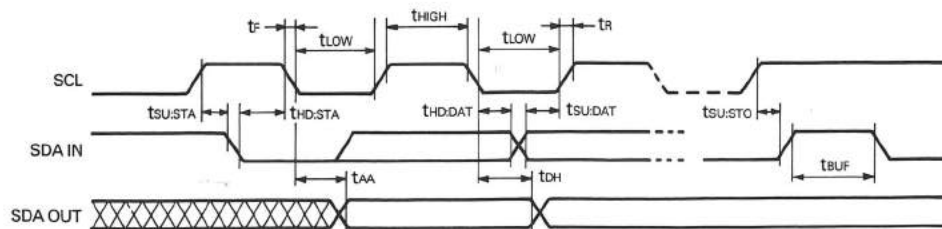

CPU : 78312AGF3343BE (Control Unit IC106)

• Terminal connection diagram

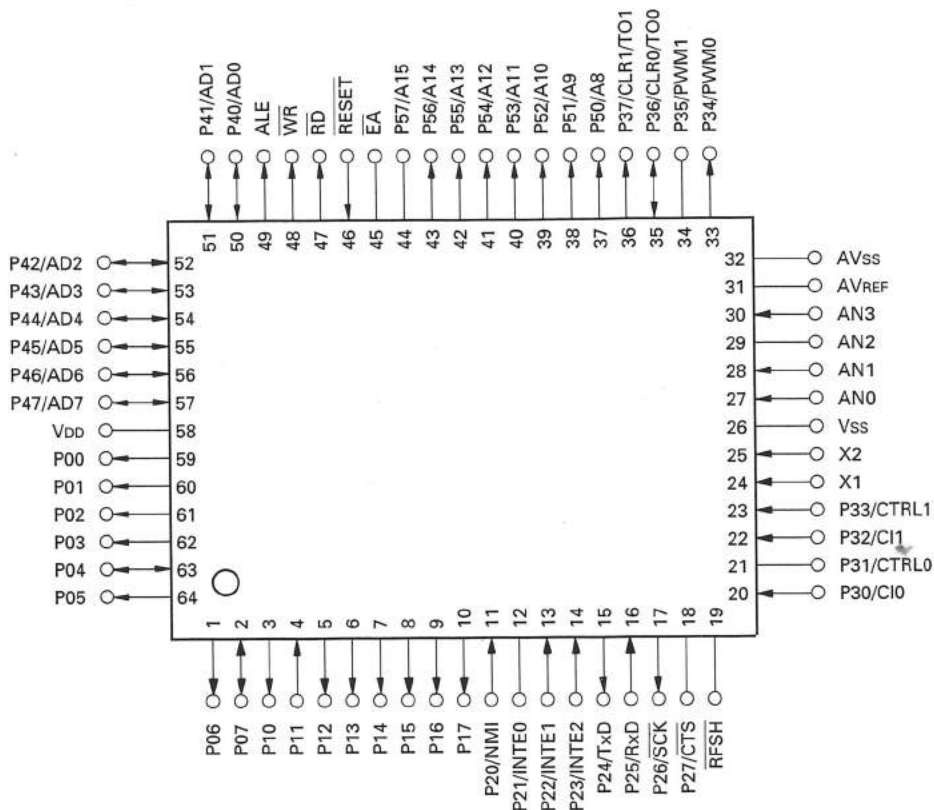

• Terminal function

Pin No.	Pin name	I/O	Function	Pin No.	Pin name	I/O	Function
1	P06	O	STROBE output.	27	AN0	I	ANALOG input (QT. DET).
2	P07	I/O	Serial data input/output (DISPLAY 2).	28	AN1	I	Not use.
3	P10	O	CLOCK output (DISPLAY 2).	29	AN2	-	GND.
4	P11	I	Dead beet disable input.	30	AN3	I	NOISE SQ REFERENCE input.
5, 6	P12, P13	O	Five-tone data rewrite output.	31	AVREF	-	+5V.
7	P14	O	Control STROBE output (BU4094BF).	32	AVss	-	GND.
8	P15	O	AC1 (SCRAMBLER) output.	33	P34/PWM0	O	PWM output, TONE output.
9	P16	O	PTT SW output.	34	P35/PWM1	-	Open (not use).
10	P17	O	Beep output (HEAD 1).	35	P36/CLR0/TO0	I/O	EEPROM (X24C04PI) serial data input/output.
11	P20/NMI	I	Backup interrupt input.	36	P37/CLR1/TO1	O	EEPROM (X24C04PI) CLOCK output.
12	P21/INTE0	-	Open (not use).	37~43	A8~A14	O	Address output.
13	P22/INTE1	I	PTT SW input.	44	P57/A15	-	Open (not use).
14	P23/INTE2	I	HOOK SW input.	45	EA	-	+5V.
15	P24/TXD	O	Serial data output (RADIO 1, 2).	46	RESET	I	System reset input.
16	P25/RXD	I	Serial data input (RADIO 1, 2).	47	RD	O	EPROM read strobe output.
17	P26/SCK	O	Beep output (HEAD 2).	48	WR	O	Open (not use).
18	P27/CTS	-	GND.	49	ALE	O	Latch enable output.
19	RFSH	-	Not use.	50~57	AD0~AD7	I/O	Address output, DATA input.
20	P30/CI0	I	Noise pulse input.	58	VDD	-	+5V.
21	P31/CTRL0	-	Not use.	59	P00	O	PLL ENABLE output.
22	P32/CI1	I	Unlock signal input.	60	P01	O	TX/RX STROBE output.
23	P33/CTRL1	I	AC2 (optional matching signal) input.	61	P02	O	CLOCK output.
24	X1	I	CLOCK input.	62	P03	O	Serial data output.
25	X2	I	CLOCK input.	63	P04	I/O	CLOCK input/output (DISPLAY 1).
26	Vss	-	GND.	64	P05	O	Serial data output (DISPLAY 1).

SEMICONDUCTOR DATA

CPU, LCD Driver : 75328GC5563B9 (Display Unit KCH-3 IC1)

• Terminal connection diagram

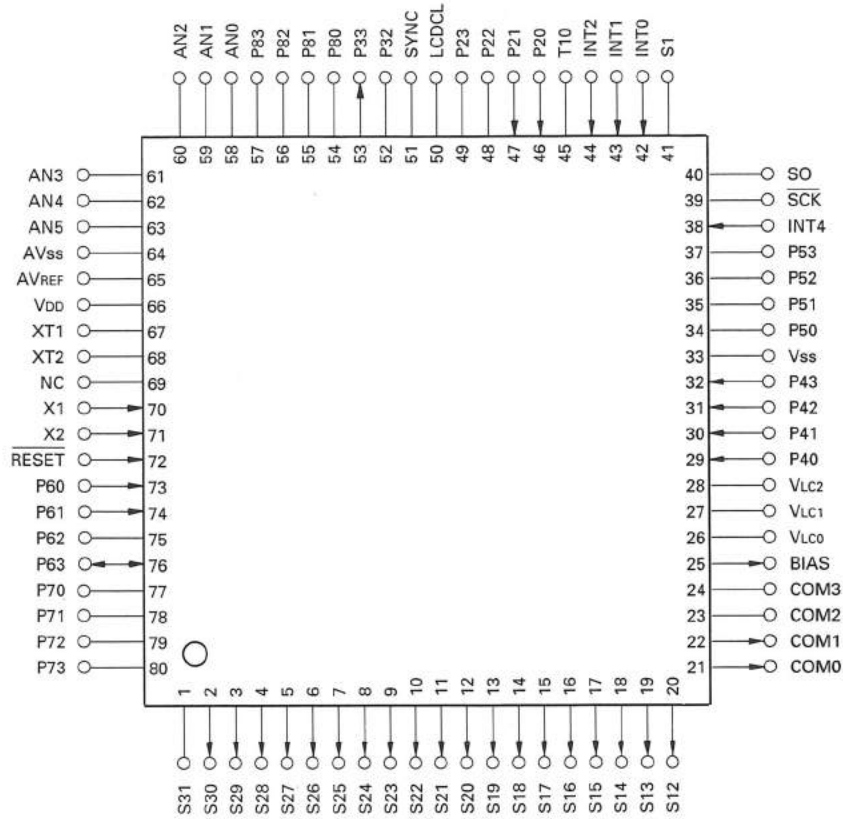

• Terminal function

Pin No.	Pin name	I/O	Function	Pin No.	Pin name	I/O	Function
1	S31/BP7	-	Open (not use).	46	P20/PT0	I	Encoder input.
2~20	S30~S12	O	LCD output (S1~S19).	47	P21	I	Encoder input.
21	COM0	O	LCD COM1 output.	48	P22/PCL	-	+5V.
22	COM1	O	LCD COM0 output.	49	P23/BUZ	-	GND.
23, 24	COM2, COM3	-	Open (not use).	50~52	P30~P32	-	Open (not use).
25	BIAS	O	LCD power supply voltage.	53	P33	O	Output for setting of AUX function.
26~28	VLC0~VLC2	-	LCD voltage level generator.	54~57	P80~P83	-	Open (not use).
29	P40	I	SCAN SW input.	58~63	AN1~AN5	-	GND.
30	P41	I	MON SW input.	64	AVss	-	GND.
31	P42	I	OPT SW input.	65~67		-	+5V.
32	P43	I	D/A SW input.	68	XT2	-	Open (not use).
33	Vss	-	GND.	69	NC (VPP)	-	+5V.
34~37	P50~P53	-	Open (not use).	70, 71	X1, X2	I	System CLOCK input.
38	P00/INT4	I	HOOK SW input.	72	RESET	I	System reset input.
39~41	P01~P03	-	GND.	73	P60/KR0	I	PTT SW input.
42	P10/INT0	I	Encoder interrupt input.	74	P61/KR1	I	HOOK SW input.
43	P11/INT1	I	PTT SW input.	75	P62/KR2	-	Open (not use).
44	P12/INT2	I	CLOCK input.	76	P63/KR3	I/O	Internal interface input/output.
45	P13/TI0	-	GND.	77~80	P70~P73	-	Open (not use).

SEMICONDUCTOR DATA

CPU : 75328GC5563B9 (Display Unit KCH-4 IC1)

• Terminal connection diagram

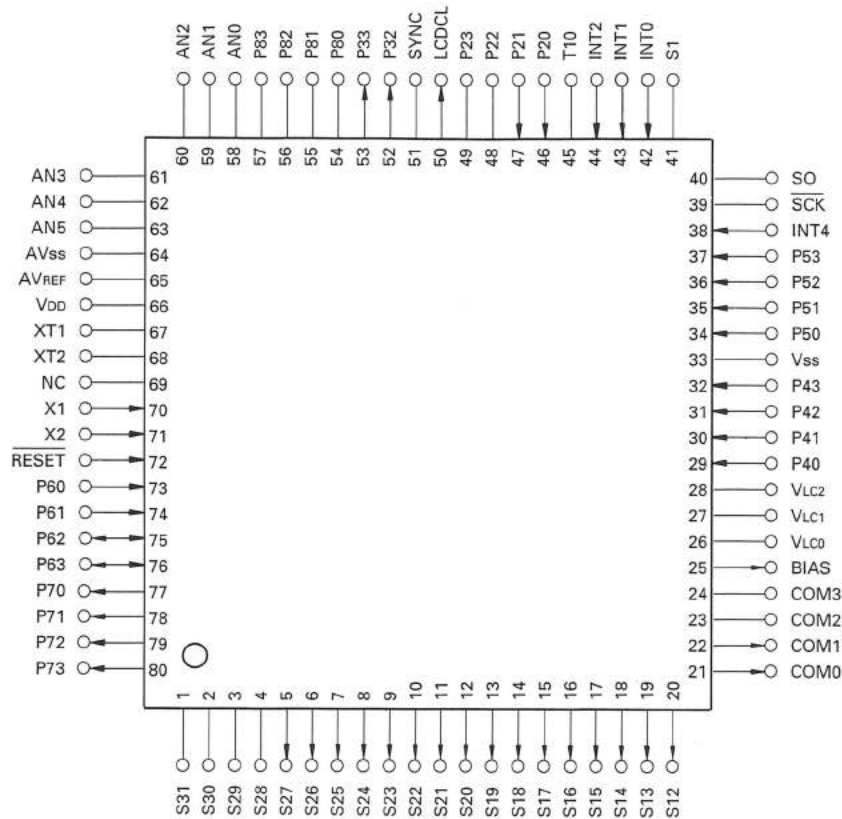

• Terminal function

Pin No.	Pin name	I/O	Function	Pin No.	Pin name	I/O	Function
1~4	S31~S28	-	Open (not use).	47	P21	I	Encoder input.
5~20	S27~S12	O	LCD output (S1~S16).	48, 49	P22, P23	-	GND.
21	COM0	O	LCD COM0 output.	50	P30/LCDCL	O	CLOCK output (MSM5265GS).
22	COM1	O	LCD COM1 output.	51	P31	-	GND.
23, 24	COM2, COM3	-	Open (not use).	52	P32	O	EEPROM (X24C04PI) CLOCK output.
25	BIAS	O	LCD power supply voltage.	53	P33	O	Output for setting of AUX function.
26~28	VLC1~VLC2	-	LCD voltage level generator.	54~57	P80~P83	-	Open (not use).
29	P40	I	MON SW input.	58~63	AN0~AN5	-	GND.
30	P41	I	SCAN SW input.	64	AVss	-	GND.
31	P42	I	KEY4 SW input.	65~67		-	+5V.
32	P43	I	KEY3 SW input.	68	XT2	-	Open (not use).
33	Vss	-	GND.	69	NC (Vpp)	-	+5V.
34	P50	I	KEY2 SW input.	70	X1	I	System CLOCK input.
35	P51	I	KEY1 SW input.	71	X2	I	System CLOCK input.
36	P52	I	DOWN SW input.	72	RESET	I	System reset input.
37	P53	I	UP SW input.	73	P60/KR0	I	PTT SW input
38	P00/INT4	I	HOOK SW input.	74	P61/KR1	I	HOOK SW input.
39~41	P01~P03	-	GND.	75	P62/KR2	I/O	EEPROM (X24C04PI) serial data input/output.
42	P10/INT0	I	Encoder interrupt input.	76	P63/KR3	I/O	Internal interface input/output.
43	P11/INT1	I	PTT SW input.	77	P70/KR4	O	LCD driver (MSM5265GS) BLANK output.
44	P12/INT2	I	CLOCK input.	78	P71/KR5	O	LCD driver (MSM5265GS) DATA output.
45	P13/TI0	-	GND.	79	P72/KR6	O	LCD driver (MSM5265GS) CLOCK output.
46	P20/PT0	I	Encoder input.	80	P73/KR7	O	LCD driver (MSM5265GS) LOAD output.

DESCRIPTION OF COMPONENTS

FINAL UNIT (X45-3390-10)

Ref. No.	Part No.	Use/Function	Operation/Condition
IC1	S-AV21H	Power amplifier	
Q1,2	2SC2782	Final amplifier	Push-pull amplifier.
Q3	2SD1406(Y)	APC controller	
Q4	2SA1162(Y)	DC amplifier	APC controller.
Q5	2SC2712(Y)	DC amplifier	APC controller.
Q6	FMW1	DC amplifier	APC controller.
Q7	FMC2	TX/RX switching	ON when RX.
Q8	2SD1682(R,S)	TX/RX switching	ON when RX.
D1	1SS101	Forward wave rectification	
D2,3	1SS101	Reflected wave rectification	
D4	1SS193	Protector	
D5	SG-5L(R)	Protection of reverse connection	
D6	02CZ10(X,Y)	Voltage reference	
D7	ERZ-M10DK220	Surge absorption	
D8	1SS184	COM biner	

CONTROL UNIT (X57-3750-10) (A/3)

Ref. No.	Part No.	Use/Function	Operation/Condition
IC101	TC4013BF	D-FF	Phase difference detection.
IC102	L78LR05B-FA	AVR	
IC103	KCE04	MIC amplifier, AF BPF, AF VOL, SQ	
IC104,105	BU4094BF	Shift register	
IC106	78312AGF3343BE	CPU	
IC107	TC74HC573AF	Latch	Separate from multiplexer address/data bus output.
IC108	27C256BQ-JBY2	EPROM	
IC109	X24C04PI	EEPROM	
Q101	DTA114EK	DC switch	ON when the power switch is held down.
Q102	DTA114EK	DC switch	ON when the power switch on.
Q103,104	DTD114EK	DC switch	ON when the power switch on.
Q105	DTC114EK	DC switch	Reset (IC106) when the power switch off.
Q106	2SC2712(Y)	DC switch	Reset (IC106) when the power switch off.
Q107	2SD1757K	Muting switch	OFF when busy.
Q108	DTC114EK	Muting switch	OFF when RX.
Q109	DTC114EK	Muting switch	OFF when PTT switch on.
Q110	DTC114EK	PTT switch	ON when PTT switch on.
Q111	DTC114EK	HOOK switch	ON when on hook.
Q112	DTC114EK	SQ level shifter	8V → 5V.
Q114	DTC114EK	DC switch	ON when 24V input → Q104 off.
Q115	DTC114EK	Beep switch	
Q116	DTD114EK	DC switch	ON when AUX key on.
D101	02CZ18(X,Y)	Voltage reference	
D102	1SS181	Reverse current prevention	
D103	1SS184	DC switch	
D104	02CZ5.6(X,Y)	Voltage reference	
D105	1SS184	Reverse current prevention	
D106	1SS184	DC switch	
D107~110	1SS226	Surge absorption	ON when 5V or more and 0V or less.
D111	1SS184	DC switch	
D112	02CZ15(X,Y)	Voltage reference	

TK-730H(B)

DESCRIPTION OF COMPONENTS

TX-RX UNIT (X57-3750-10) (B/3)

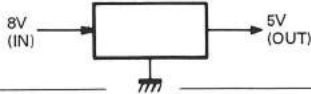
Ref. No.	Part No.	Use/Function	Operation/Condition
IC301	MC3371D	IF system	1,2 : Oscillator (34.855MHz) 3 : Mixer output 4 : Vcc 5 : Limiter input 6,7 : Decoupling 8 : Quad input 9 : AF output 16 : Input (34.4MHz)
IC302	KCB05	Drive amplifier	
IC303	BU4094BF	Shift register	
IC304	NJM78L05UA	Voltage regulator	
Q301	3SK184(S)	RF amplifier	
Q302	3SK140(GR)	RX 1st mixer	
Q303	2SC2714(Y)	RX 1st IF amplifier	34.4MHz.
Q304	2SC2714(Y)	RF amplifier	(RX frequency - 34.4) MHz,
Q305	2SK208(Y)	DC amplifier	PLL lock voltage.
Q306	2SB1119S	DC switch	RX : 8V, TX : 0V.
Q307	DTC114EK	DC switch	ON when RX.
Q308	2SB1119S	DC switch	RX : 0V, TX : 8V.
Q309	DTC114EK	DC switch	ON when TX.
Q310	DTC114EK	DC switch	Reset (shift register BU4094BF).
Q311	DTC114EK	MIC mute switch	ON when RX.
D301	1SS226	Protector	
D302	1SV164	BPF tuning	Vari-cap tuning.
D303	1SV166	BPF tuning	Vari-cap tuning.
D304	1SV164	BPF tuning	Vari-cap tuning.
D305	1SV166	BPF tuning	Vari-cap tuning.
D306-308	1SV164	BPF tuning	Vari-cap tuning.
D309	1SS184	RF switch	Common VCO output.
D310	1SV164	1st OSC tuning	Vari-cap tuning.
D311	1SV166	1st OSC tuning	Vari-cap tuning.

AF UNIT (X57-3750-10) (C/3)

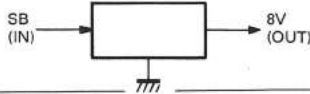
Ref. No.	Part No.	Use/Function	Operation/Condition
IC501	LA4491N	Audio power amplifier	
IC502	μPC78M08H	AVR	
Q501	DTD114EK	Speaker switch	ON when PA SP switch on.
D501,502	1SS193	Reverse current prevention	
D503	1SS184	Protector	ON when the power switch off.

VCO/PLL UNIT (X58-3810-10)

Ref. No.	Part No.	Use/Function	Operation/Condition
IC1	MB1504PF	PLL system	1 : TCXO input 4 : 5V 7 : LD ("H" when lock) 8 : VCO output 9 (CLK), 10 (DAT), 11 (LE) : PLL data input 15 (P), 16 (R) : Charge pump output
Q1	2SC2714(Y)	RF amplifier	
Q2	2SC2714(Y)	Buffer amplifier	
Q3	2SA1162(Y)	Lock detect switch	"H" when lock.
Q4	DTC143EK	Lock detect switch	"H" when lock.
Q5	2SA1312(GR)	Charge pump	D/A converter.

DESCRIPTION OF COMPONENTS

Ref. No.	Part No.	Use/Function	Operation/Condition
Q6	2SC3324(G)	Charge pump	D/A converter.
Q51	2SK508NV(K52)	OSC	TX-VCO.
Q52	2SK508NV(K52)	OSC	RX-VCO.
Q53	2SC2714(Y)	Buffer amplifier	
Q54	DTC114EK	TX/RX switching	
Q55	FMG2	TX/RX switching	
D1	MA77		
D51	1SV164	Modulator	
D52,53	1T33C	Vari-cap diode	Frequency controller (TX-VCO).
D54,55	1T33C	Vari-cap diode	Frequency controller (RX-VCO).

DISPLAY UNIT (X54-3100-20) : KCH-3

Ref. No.	Part No.	Use/Function	Operation/Condition
IC1	75328GC5563B9	CPU, LCD driver	
IC2	L78LR05B-FA	AVR	
Q1	DTD114EK	LED or AUX switch	ON when AUX key on.
Q2	DTC114EK	DC switch	OFF when AUX key on.
D1~4	1SS226	Surge absorption	ON when 5V or more and 0V or less.
D5	1SS181	Encoder interrupt	
D6	B38-0322-05	LED assy	LCD back light.
ED1	B38-0353-05	LCD	

DISPLAY UNIT (X54-3110-20) : KCH-4

Ref. No.	Part No.	Use/Function	Operation/Condition
IC1	75328GC5563B9	CPU	
IC2	L78LR05B-FA	AVR	
IC3	X24C04PI	EEPROM	
IC4	MSM5265GS-V1K	LCD driver	
Q1	DTD114EK	LED or AUX switch	ON when AUX key on.
Q2	2SC2873(Y)	DC switch	
Q3	FMC5	LED switch	OFF when AUX key on.
D1~4	1SS226	Surge absorption	ON when 5V or more and 0V or less.
D5	1SS181	Encoder interrupt.	
D6	02CZ10(X,Y)	Voltage reference	
D7	B38-0352-05	LED assy	LCD back light.
ED1	B38-0354-05	LCD	

TK-730H(B)

PARTS LIST

× New Parts

Parts without Parts No. are not supplied.

Les articles non mentionnés dans le Parts No. ne sont pas fournis.

Teile ohne Parts No. werden nicht geliefert.

TK-730H(B)

FINAL UNIT (X45-3390-10)

Ref. No. 参照番号	Address 位置	New Parts 新	Parts No. 部品番号	Description 部品名 / 規格	Desti- nation 仕向	Re- marks 備考
TK-730H(B)						
1	3B	*	A01-2020-01	CASE(UPPER)		
2	1A	*	A01-2025-01	CASE(LOWER)		
3	2B	*	A10-1320-01	FRAME		
5	3A		B42-3343-04	LABEL(S/NO)		
7	1G	*	B62-0069-00	INSTRUCTION MANUAL		
8	3A	*	B72-0149-04	MODEL NAME PLATE(F1)		
6	1G		B46-0409-30	WARRANTY CARD		
10	1H		E30-2036-05	GROUND LEAD WIRE		
11	2A, 1H		E31-3228-05	SHORT PLUG(ACC)		
12	2B		E31-3301-05	CONNECTING WIRE(RA/DO)		
13	2B	*	E37-0153-05	FLEXIBLE PC BOARD(17P)		
14	2B	*	E37-0154-05	FLEXIBLE PC BOARD(13P)		
15	1H	*	F07-1336-05	COVER		
17	1A	*	F10-1488-02	SHIELDING PLATE(FINAL)		
22	2B		G02-0574-04	LEAF SPRING(AVR)		
23	2B	*	G02-0709-04	LEAF SPRING(AF.AMP)		
24	3B	*	G10-0707-14	NON-WOVEN FABRIC		
25	3B	*	G13-1354-04	CUSHION(IC108)		
26	3B	*	G53-0713-13	PACKING(CASE/UPPER)		
27	1A	*	G53-0716-13	PACKING(CASE/LOWER)		
29	1G		H02-0604-03	INNER PACKING CASE		
30	1H		H11-0815-04	POLYSTYRENE PLATE		
31	1H	*	H11-0853-04	POLYSTYRENE PLATE		
32	3G	*	H52-0092-04	ITEM CARTON BOX		
33	2H	*	H10-2731-01	POLYSTYRENE FOAMED FIXTURE		
34	2G		H12-1399-04	PACKING FIXTURE, CARTON BOARD		
35	2G		H12-1410-04	PACKING FIXTURE, CARTON BOARD		
36	2G	*	H12-1434-04	PACKING FIXTURE, CARTON BOARD		
37	2H	*	H12-1442-04	PACKING FIXTURE, CARTON BOARD		
38	1H		H25-0096-04	PROTECTION BAG		
39	1H		H25-0103-04	PROTECTION BAG(125X250)		
40	1G		H25-0724-04	PROTECTION BAG(RADIO)		
41	1H		J61-0307-05	WIRE BAND		
A	1A		N35-3006-46	BINDING HEAD MACHINE SCREW		
B	1B, 3B		N35-3008-45	BINDING HEAD MACHINE SCREW		
C	2B, 3B		N87-2606-46	BRAZIER HEAD TAPTITE SCREW		
42	1H	*	N99-0365-05	SCREW SET		
44	1B	*	X45-3390-10	FINAL UNIT		
45	2B, 3B	*	X57-3750-10	TX.RX UNIT		
FINAL UNIT (X45-3390-10)						
C1		*	C90-2165-05	ELECTRO	10UF	50WV
C2			CK73EB1H104K	CHIP C	0.10UF	K
C3			CK73FB1H102K	CHIP C	1000PF	K
C4			C90-2143-05	ELECTRO	47UF	25WV
C5			CK73FB1H102K	CHIP C	1000PF	K
C6			CM73F2H430J	CHIP C	43PF	J
C7			CM73F2H131J	CHIP C	130PF	J
C8			CM73F2H201J	CHIP C	200PF	J
C9	, 10		CM73F2H681J	CHIP C	680PF	J
C11	, 12		CM73F2H131J	CHIP C	130PF	J

L:Scandinavia

K:USA

P:Canada

Y:PX(Far East, Hawaii)

T:England

E:Europe

Y:AAFES(Europe)

X:Australia

M:Other Areas

 indicates safety critical components.

PARTS LIST

× New Parts

Parts without Parts No. are not supplied.

Les articles non mentionnés dans le Parts No. ne sont pas fournis.

Teile ohne Parts No. werden nicht geliefert.

FINAL UNIT (X45-3390-10)

Ref. No. 参照番号	Address 位置	New Parts 新	Parts No. 部品番号	Description 部品名 / 規格	Desti- nation 仕 向	Re- marks 備考
C13 -16			CM73F2H271J	CHIP C 270PF J		
C17 -20			CM73F2H221J	CHIP C 220PF J		
C21			CK73FB1H102K	CHIP C 1000PF K		
C22			CK73FB1H103K	CHIP C 0.010UF K		
C23			CK73EB1H104K	CHIP C 0.10UF K		
C24		*	C90-2165-05	ELECTRO 10UF 50WV		
C25			CK73FB1H102K	CHIP C 1000PF K		
C26			CK73FB1H103K	CHIP C 0.010UF K		
C27			CK73EB1H104K	CHIP C 0.10UF K		
C28		*	C90-2165-05	ELECTRO 10UF 50WV		
C29 ,30			CK73FB1H102K	CHIP C 1000PF K		
C31 ,32			CM73F2H681J	CHIP C 680PF J		
C33			CM73F2H620J	CHIP C 62PF J		
C34			CM73F2H470J	CHIP C 47PF J		
C35			CM73F2H100D	CHIP C 10PF D		
C36			CC73FCH1H220J	CHIP C 22PF J		
C37			CK73FB1H102K	CHIP C 1000PF K		
C38			CC73FCH1H100D	CHIP C 10PF D		
C39 ,40			CK73FB1H102K	CHIP C 1000PF K		
C41			CM73F2H130J	CHIP C 13PF J		
C42 ,43			CM73F2H360J	CHIP C 36PF J		
C44			CM73F2H080D	CHIP C 8.0PF D		
C45			CM73F2H130J	CHIP C 13PF J		
C46 -54			CK73FB1H102K	CHIP C 1000PF K		
C55			C90-2020-05	ELECTRO 15UF 25WV		
C56			CK73FB1H102K	CHIP C 1000PF K		
C57		*	C90-2165-05	ELECTRO 10UF 50WV		
C58 -65			CK73FB1H102K	CHIP C 1000PF K		
C66 ,67			C90-2155-05	ELECTRO 470UF 25WV		
C68 -70			CK73FB1H102K	CHIP C 1000PF K		
C71			CM73F2H620J	CHIP C 62PF J		
C72			C90-2090-05	ELECTRO 220UF 25WV		
CN1 ,2			E04-0154-05	RF COAXIAL CABLE RECEPTACLE		
CN3 ,4			E23-0491-05	TERMINAL		
J2	2A		E04-0167-05	RF COAXIAL CABLE RECEPTACLE		
W1		*	E37-0138-05	CONNECTING WIRE(3P)		
W2		*	E37-0139-05	CONNECTING WIRE(4P)		
W3 ,4		*	E37-0183-05	FINISHED WIRE		
W6	2A	*	E37-0160-05	CONNECTING WIRE(2P)		
W7	2A	*	E37-0161-15	CONNECTING WIRE(15P)		
101	2A	*	G53-0715-03	PACKING		
102	2A	*	J21-4351-04	MOUNTING HARDWARE		
103	2A, 2B	*	J32-0919-04	STUD, BOSS		
			J61-0307-05	WIRE BAND		
L1			L34-1039-05	COIL		
L2			L39-0421-04	COIL		
L3 ,4			L33-0717-05	CHOKE COIL		
L5 ,6			L34-1231-05	COIL		
L7			L34-1246-05	COIL		
L8			L34-1247-05	COIL		
L9 ,10			L34-1232-05	COIL		
L11			L34-1231-05	COIL		
L12			L34-1088-05	COIL		

L:Scandinavia

K:USA

P:Canada

Y:PX(Far East, Hawaii)

T:England

E:Europe

Y:AAFES(Europe)

X:Australia

M:Other Areas

△ indicates safety critical components.

TK-730H(B)

PARTS LIST

× New Parts

Parts without Parts No. are not supplied.

Les articles non mentionnés dans le Parts No. ne sont pas fournis.

Teile ohne Parts No. werden nicht geliefert.

FINAL UNIT (X45-3390-10)

TX-RX UNIT (X57-3750-10)

Ref. No. 参照番号	Address 位置	New Parts 新	Parts No. 部品番号	Description 部品名 / 規格	Desti- nation 仕 向	Re- marks 備考
D	1B, 2B		N09-2077-05	SCREW(M3X8/ ICI, Q1, Q2, Q3)		
E	1B		N35-3006-46	BINDING HEAD MACHINE SCREW		
F	1B		N87-2606-46	BRAZIER HEAD TAPTITE SCREW		
G	2A		N87-3008-46	BRAZIER HEAD TAPTITE SCREW		
R1	, 2		RD14DB3A3R3J	SMALL-RD 3.3 J 1W		
R3	, 4		R92-1204-05	CARBON 33 J 1/4W		
R5			RK73FB2A473J	CHIP R 47K J 1/10W		
R6			RK73FB2A471J	CHIP R 470 J 1/10W		
R7			RK73FB2A472J	CHIP R 4.7K J 1/10W		
R8			RK73FB2A122J	CHIP R 1.2K J 1/10W		
R9			RK73FB2A101J	CHIP R 100 J 1/10W		
R10			RK73FB2A122J	CHIP R 1.2K J 1/10W		
R12			RK73FB2A471J	CHIP R 470 J 1/10W		
R13			RK73FB2A272J	CHIP R 2.7K J 1/10W		
R11, 14			RK73FB2A103J	CHIP R 10K J 1/10W		
VR1			R12-3126-05	TRIMMING POT. 10K		
W5			R92-1061-05	JUMPER REST 0 OHM		
K1			S51-1437-05	RELAY		
D1	-3		1SS101	DIODE		
D4			1SS193	DIODE		
D5			SG-5L(R)	DIODE		
D6			O2CZ10(X, Y)	DIODE		
D7			ERZ-M10DK220	SERGE ABSORBER		
D8			1SS184	DIODE		
IC1	2B		S-AV21H	IC(POWER MODULE)		
Q1	, 2		2SC2782	TRANSISTOR(POWER AMP.)		
Q3	1B		2SD1406(Y)	TRANSISTOR		
Q4			2SA1162(Y)	TRANSISTOR		
Q5			2SC2712(Y)	TRANSISTOR		
Q6			FMW1	TRANSISTOR		
Q7			FMC2	TRANSISTOR		
Q8			2SD1682(R, S)	TRANSISTOR		
TH1		*	PTH9M04BC471TS	POSISTOR		
			212-0702-05	PLASTIC TUBE		
TX-RX UNIT (X57-3750-10)						
C101			CK73FB1E104K	CHIP C 0.10UF K		
C102			CE04EW1E470M	ELECTRO 47UF 25WV		
C103			CK73FB1H102K	CHIP C 1000PF K		
C104, 105			C92-0007-05	CHIP TAN 2.2UF 10WV		
C106			CK73FB1H102K	CHIP C 1000PF K		
C107			CE04EW1E100M	ELECTRO 10UF 25WV		
C108			CE04EW1E470M	ELECTRO 47UF 25WV		
C109			CK73FB1H102K	CHIP C 1000PF K		
C110			C92-0003-05	CHIP TAN 0.47UF 25WV		
C111			CE04EW1C470M	ELECTRO 47UF 16WV		
C112			CK73FB1H102K	CHIP C 1000PF K		
C113			CK73FB1E103K	CHIP C 0.01UF K		
C114			C92-0004-05	ELECTRO 1.0UF 16WV		
C115			CK73FB1E104K	CHIP C 0.10UF K		
C116			CE04EW1C470M	ELECTRO 47UF 16WV		
C117			CK73FB1H102K	CHIP C 1000PF K		
C118			C92-0008-05	CHIP TAN 3.3UF 16WV		
C119			CK73EF1C105Z	CHIP C 1.0UF Z		

L:Scandinavia

K:USA

P:Canada

Y:PX(Far East, Hawaii)

T:England

E:Europe

Y:AAFES(Europe)

X:Australia

M:Other Areas

 indicates safety critical components.

PARTS LIST

× New Parts

Parts without Parts No. are not supplied.

Les articles non mentionnés dans le Parts No. ne sont pas fournis.

Teile ohne Parts No. werden nicht geliefert.

TX-RX UNIT (X57-3750-10)

Ref. No. 参照番号	Address 位置	New Parts 新	Parts No. 部品番号	Description 部品名 / 規格	Desti- nation 仕 向	Re- marks 備考
C120			C92-0007-05	CHIP TAN 2.2UF 10WV		
C121			CK73FB1E104K	CHIP C 0.10UF K		
C122			CE04EW1C470M	ELECTRO 47UF 16WV		
C123			CK73FB1H102K	CHIP C 1000PF K		
C124			CK73EF1C105Z	CHIP C 1.0UF Z		
C125			CK73FB1E473K	CHIP C 0.047UF K		
C126			CK73FB1H102K	CHIP C 1000PF K		
C127, 128			CK73FB1E103K	CHIP C 0.01UF K		
C129			CK73FB1H102K	CHIP C 1000PF K		
C130			CE04EW1C101M	ELECTRO 100UF 16WV		
C131			CK73FB1H471K	CHIP C 470PF K		
C132, 133			CK73FB1H102K	CHIP C 1000PF K		
C134, 135			CC73FCH1H100D	CHIP C 10PF D		
C136			CK73FB1E104K	CHIP C 0.10UF K		
C137-138			CK73FB1E103K	CHIP C 0.01UF K		
C139			CK73FB1E104K	CHIP C 0.10UF K		
C140			CK73FB1H471K	CHIP C 470PF K		
C141-143			CK73FB1E103K	CHIP C 0.01UF K		
C144, 145			CK73FB1H102K	CHIP C 1000PF K		
C147-149			CK73FB1H102K	CHIP C 1000PF K		
C150			CC73FSL1H101J	CHIP C 100PF J		
C151-154			CK73FB1H102K	CHIP C 1000PF K		
C155-158			CC73FSL1H101J	CHIP C 100PF J		
C159			CK73FB1H102K	CHIP C 1000PF K		
C160			CC73FSL1H101J	CHIP C 100PF J		
C161, 162			CK73FB1H102K	CHIP C 1000PF K		
C164-166			CK73FB1H102K	CHIP C 1000PF K		
C167, 168			CC73FSL1H101J	CHIP C 100PF J		
C169-173			CK73FB1H102K	CHIP C 1000PF K		
C183			CK73FB1H102K	CHIP C 1000PF K		
C185-193			CK73FB1H102K	CHIP C 1000PF K		
C195, 196			CC73FSL1H101J	CHIP C 100PF J		
C197			CK73FB1E103K	CHIP C 0.01UF K		
C198, 199			CC73FSL1H101J	CHIP C 100PF J		
C200-206			CK73FB1H102K	CHIP C 1000PF K		
C207-209			CC73FSL1H101J	CHIP C 100PF J		
C210			CK73FB1H102K	CHIP C 1000PF K		
C211			CC73FSL1H101J	CHIP C 100PF J		
C212-216			CK73FB1H102K	CHIP C 1000PF K		
C301			CC73FCH1H030C	CHIP C 3PF C		
C302-305			CK73FB1H102K	CHIP C 1000PF K		
C306			CK73FB1E103K	CHIP C 0.01UF K		
C307			CC73FCH1H330J	CHIP C 33PF J		
C308			CC73FCH1H0R5C	CHIP C 0.5PF C		
C309			CK73FB1E103K	CHIP C 0.01UF K		
C310			CC73FCH1H020C	CHIP C 2.0PF C		
C311			CC73FCH1H0R5C	CHIP C 0.5PF C		
C312			CK73FB1H102K	CHIP C 1000PF K		
C313			CC73FCH1H180J	CHIP C 18PF J		
C314			CC73FCH1H030C	CHIP C 3PF C		
C315			CK73FB1E103K	CHIP C 0.01UF K		
C316-317			CK73FB1H102K	CHIP C 1000PF K		
C318			CK73FB1E103K	CHIP C 0.01UF K		
C319			CC73FCH1H100D	CHIP C 10PF D		
C320, 321			CK73FB1H102K	CHIP C 1000PF K		

L:Scandinavia

K:USA

P:Canada

Y:PX(Far East, Hawaii)

T:England

E:Europe

Y:AAFES(Europe)

X:Australia

M:Other Areas

△ indicates safety critical components.

PARTS LIST

× New Parts

Parts without Parts No. are not supplied.

Les articles non mentionnés dans le Parts No. ne sont pas fournis.

Teile ohne Parts No. werden nicht geliefert.

TX-RX UNIT (X57-3750-10)

Ref. No. 参照番号	Address 位置	New Parts 新	Parts No. 部品番号	Description 部品名 / 規格	Desti- nation 仕向	Re- marks 備考
C322			CC73FCH1H390J	CHIP C 39PF J		
C323, 324			CK73FB1E104K	CHIP C 0.10UF K		
C325			C92-0009-05	CHIP TAN 4.7UF 10WV		
C326			CK73FB1E103K	CHIP C 0.01UF K		
C327			CK73FB1H102K	CHIP C 1000PF K		
C328			C92-0009-05	CHIP TAN 4.7UF 10WV		
C329, 330			CK73FB1H102K	CHIP C 1000PF K		
C331, 332			CC73FCH1H220J	CHIP C 22PF J		
C333, 334			CC73FSL1H101J	CHIP C 100PF J		
C335			CK73FB1H102K	CHIP C 1000PF K		
C336			CC73FSL1H101J	CHIP C 100PF J		
C337			CK73FB1H102K	CHIP C 1000PF K		
C339-342			CK73FB1H102K	CHIP C 1000PF K		
C343			C92-0007-05	CHIP TAN 2.2UF 10WV		
C344			CE04LW1C221M	ELECTRØ 220UF 16WV		
C345-347			CK73FB1H102K	CHIP C 1000PF K		
C348			CC73FCH1H150J	CHIP C 15PF J		
C349			CK73FF1C105Z	CHIP C 1.0UF Z		
C350-352			CK73FB1H102K	CHIP C 1000PF K		
C353			CC73FCH1H180J	CHIP C 18PF J		
C354			CC73FCH1H120J	CHIP C 12PF J		
C355, 356			CK73FB1H102K	CHIP C 1000PF K		
C358-363			CK73FB1H102K	CHIP C 1000PF K		
C364			CE04EW1C470M	ELECTRØ 47UF 16WV		
C365-367			CK73FB1H102K	CHIP C 1000PF K		
C368			CE04EW1C101M	ELECTRØ 100UF 16WV		
C369			CK73FB1E103K	CHIP C 0.01UF K		
C370			CK73FB1H102K	CHIP C 1000PF K		
C371			CK73FB1E103K	CHIP C 0.01UF K		
C372			CK73FB1H102K	CHIP C 1000PF K		
C373			CC73FCH1H470J	CHIP C 47PF J		
C374			CK73FB1H102K	CHIP C 1000PF K		
C375			CC73FCH1H180J	CHIP C 18PF J		
C501-504			CK73FB1H102K	CHIP C 1000PF K		
C509			CE04EW1HØR1M	ELECTRØ 0.1UF 50WV		
C510			CK73FB1E103K	CHIP C 0.01UF K		
C511			C90-2024-05	ELECTRØ 47UF 6.3WV		
C512			CE04EW1C101M	ELECTRØ 100UF 16WV		
C513			CE04LW1C221M	ELECTRØ 220UF 16WV		
C514			C90-2024-05	ELECTRØ 47UF 6.3WV		
C515, 516			CE04LW1C221M	ELECTRØ 220UF 16WV		
C517, 518			CQ92FM1H104K	MYLAR 0.10UF K		
C519, 520			CK73FB1H102K	CHIP C 1000PF K		
C521-522			CK73FB1E103K	CHIP C 0.01UF K		
C523			CK73FB1E103K	CHIP C 0.01UF K		
C524			CE04EW1E471M	ELECTRØ 470UF 25WV		
CN101			E02-2010-05	TRANSISTØR SØCKET(8P)		
CN102			E02-2015-05	TRANSISTØR SØCKET(28P)		
CN103			E40-5491-05	PIN CØNNECTØR(17P)		
			E40-5470-05	PIN CØNNECTØR(13P)		
			E40-3269-05	PIN CØNNECTØR(11P)		
CN104			E40-3243-05	PIN CØNNECTØR(8P)		
CN105			E40-3242-05	PIN CØNNECTØR(7P)		
CN106			E40-3253-05	PIN CØNNECTØR(9P)		

L:Scandinavia

K:USA

P:Canada

Y:PX(Far East, Hawaii)

T:England

E:Europe

Y:AAFES(Europe)

X:Australia

M:Other Areas

⚠ indicates safety critical components.

PARTS LIST

× New Parts

Parts without Parts No. are not supplied.

Les articles non mentionnés dans le Parts No. ne sont pas fournis.

Teile ohne Parts No. werden nicht geliefert.

TX-RX UNIT (X57-3750-10)

Ref. No. 参照番号	Address 位置	New Parts 新	Parts No. 部品番号	Description 部品名 / 規格	Desti- nation 仕 向	Re- marks 備考
CN107			E40-3251-05	PIN CONNECTOR(7P)		
CN108			E40-3256-05	PIN CONNECTOR(12P)		
CN301			E04-0154-05	RF COAXIAL CABLE RECEPTACLE		
CN302		*	E40-5492-05	PIN CONNECTOR(2301,15P)		
CN303			E04-0154-05	RF COAXIAL CABLE RECEPTACLE		
CN304			E40-3239-05	PIN CONNECTOR(4P)		
CN305			E40-5470-05	PIN CONNECTOR(13P)		
CN501			E40-5491-05	PIN CONNECTOR(17P)		
CN502		*	E40-3238-05	PIN CONNECTOR(3P)		
W105			E37-0158-05	CONNECTING WIRE(11P)		
			J30-0545-05	SPACER		
CF301			L72-0342-05	CERAMIC FILTER		
L301-304			L34-4080-05	COIL		
L305			L34-4191-05	COIL		
L306			L40-1095-48	SMALL FIXED INDUCTOR(1U)		
L307			L30-0503-05	IFT		
L308			L40-1001-48	SMALL FIXED INDUCTOR(10U)		
L309			L40-2211-48	SMALL FIXED INDUCTOR(220U)		
L310			L40-2782-48	SMALL FIXED INDUCTOR(270N)		
L311			L34-0956-05	COIL		
X101			L77-1374-05	CRYSTAL RESONATOR(12MHZ)		
X301		*	L77-1415-05	CRYSTAL RESONATOR(34.855MHZ)		
X302			L77-1466-05	CRYSTAL RESONATOR(12.8MHZ)		
XF301			L71-0298-05	CRYSTAL FILTER(34.4MHZ)		
R101			RK73FB2A471J	CHIP R 470 J 1/10W		
R102, 103			RK73FB2A473J	CHIP R 47K J 1/10W		
R104			RK73FB2A105J	CHIP R 1.0M J 1/10W		
R105			R92-0670-05	CHIP R 0 OHM		
R106-108			RK73FB2A104J	CHIP R 100K J 1/10W		
R109			RK73FB2A103J	CHIP R 10K J 1/10W		
R110, 111			RK73FB2A472J	CHIP R 4.7K J 1/10W		
R112			RK73FB2A223J	CHIP R 22K J 1/10W		
R113			RK73FB2A101J	CHIP R 100 J 1/10W		
R114, 115			RK73FB2A271J	CHIP R 270 J 1/10W		
R116			RK73FB2A393J	CHIP R 39K J 1/10W		
R117			RK73FB2A104J	CHIP R 100K J 1/10W		
R118			RK73FB2A103J	CHIP R 10K J 1/10W		
R119			RK73FB2A473J	CHIP R 47K J 1/10W		
R120			RK73FB2A222J	CHIP R 2.2K J 1/10W		
R121			RK73FB2A562J	CHIP R 5.6K J 1/10W		
R122			RK73FB2A103J	CHIP R 10K J 1/10W		
R123			RK73FB2A183J	CHIP R 18K J 1/10W		
R124, 125			RK73FB2A104J	CHIP R 100K J 1/10W		
R126			RK73FB2A183J	CHIP R 18K J 1/10W		
R127			RK73FB2A223J	CHIP R 22K J 1/10W		
R128			RK73FB2A102J	CHIP R 1.0K J 1/10W		
R129			RK73FB2A104J	CHIP R 100K J 1/10W		
R130, 131			RK73FB2A102J	CHIP R 1.0K J 1/10W		
R132			RK73FB2A103J	CHIP R 10K J 1/10W		
R133			RK73FB2A224J	CHIP R 220K J 1/10W		
R134			RK73FB2A101J	CHIP R 100 J 1/10W		
R135-137			RK73FB2A473J	CHIP R 47K J 1/10W		
R138			RK73FB2A333J	CHIP R 33K J 1/10W		
R139-142			RK73FB2A473J	CHIP R 47K J 1/10W		

L:Scandinavia

K:USA

P:Canada

Y:PX(Far East, Hawaii)

T:England

E:Europe

Y:AAFES(Europe)

X:Australia

M:Other Areas

⚠ indicates safety critical components.

PARTS LIST

× New Parts

Parts without Parts No. are not supplied.

Les articles non mentionnes dans le Parts No. ne sont pas fournis.

Teile ohne Parts No. werden nicht geliefert.

TX-RX UNIT (X57-3750-10)

Ref. No. 参照番号	Address 位置	New Parts 新	Parts No. 部品番号	Description 部品名 / 規格	Desti- nation 仕向	Re- marks 備考
R143, 144			RK73FB2A102J	CHIP R 1.0K J 1/10W		
R145-148			RK73FB2A473J	CHIP R 47K J 1/10W		
R149			RK73FB2A223J	CHIP R 22K J 1/10W		
R150			R92-0670-05	CHIP R 0 ΩHM		
R151, 152			RK73FB2A682J	CHIP R 6.8K J 1/10W		
R153			RK73FB2A223J	CHIP R 22K J 1/10W		
R154			RK73FB2A473J	CHIP R 47K J 1/10W		
R155			RK73FB2A104J	CHIP R 100K J 1/10W		
R156			R92-0670-05	CHIP R 0 ΩHM		
R157			RK73FB2A473J	CHIP R 47K J 1/10W		
R158			RK73FB2A272J	CHIP R 2.7K J 1/10W		
R159			R92-0670-05	CHIP R 0 ΩHM		
R160			RK73FB2A104J	CHIP R 100K J 1/10W		
R161, 162			RK73FB2A473J	CHIP R 47K J 1/10W		
R166			RK73FB2A103J	CHIP R 10K J 1/10W		
R167-169			RK73FB2A473J	CHIP R 47K J 1/10W		
R170			RK73FB2A220J	CHIP R 22 J 1/10W		
R301			RK73FB2A473J	CHIP R 47K J 1/10W		
R302			RK73FB2A273J	CHIP R 27K J 1/10W		
R303			RK73FB2A274J	CHIP R 270K J 1/10W		
R304			RK73FB2A470J	CHIP R 47 J 1/10W		
R305			RK73FB2A103J	CHIP R 10K J 1/10W		
R306			RK73FB2A101J	CHIP R 100 J 1/10W		
R307-311			RK73FB2A473J	CHIP R 47K J 1/10W		
R312			RK73FB2A331J	CHIP R 330 J 1/10W		
R313			R92-0670-05	CHIP R 0 ΩHM		
R314			RK73FB2A102J	CHIP R 1.0K J 1/10W		
R315			RK73FB2A101J	CHIP R 100 J 1/10W		
R316			RK73FB2A681J	CHIP R 680 J 1/10W		
R317			RK73FB2A223J	CHIP R 22K J 1/10W		
R318			RK73FB2A472J	CHIP R 4.7K J 1/10W		
R319			RK73FB2A473J	CHIP R 47K J 1/10W		
R320			RK73FB2A223J	CHIP R 22K J 1/10W		
R321, 322			RK73FB2A332J	CHIP R 3.3K J 1/10W		
R323			RK73FB2A101J	CHIP R 100 J 1/10W		
R324			RK73FB2A100J	CHIP R 10 J 1/10W		
R325			RK73FB2A682J	CHIP R 6.8K J 1/10W		
R326			RK73FB2A105J	CHIP R 1.0M J 1/10W		
R327			RK73FB2A471J	CHIP R 470 J 1/10W		
R328			RK73FB2A104J	CHIP R 100K J 1/10W		
R329, 330			RK73FB2A102J	CHIP R 1.0K J 1/10W		
R331			RK73FB2A103J	CHIP R 10K J 1/10W		
R332			RK73FB2A223J	CHIP R 22K J 1/10W		
R333			RK73FB2A271J	CHIP R 270 J 1/10W		
R334			RK73FB2A101J	CHIP R 100 J 1/10W		
R335-337			RK73FB2A473J	CHIP R 47K J 1/10W		
R338			RK73FB2A104J	CHIP R 100K J 1/10W		
R339			RK73FB2A473J	CHIP R 47K J 1/10W		
R340			RK73FB2A100J	CHIP R 10 J 1/10W		
R341			R92-0670-05	CHIP R 0 ΩHM		
R342			RK73FB2A473J	CHIP R 47K J 1/10W		
R343			RK73FB2A102J	CHIP R 1.0K J 1/10W		
R344-346			RK73FB2A473J	CHIP R 47K J 1/10W		
R347			R92-1211-05	SOLID R 5.6K J 1/2W		
R348-350			RK73FB2A102J	CHIP R 1.0K J 1/10W		

L:Scandinavia

K:USA

P:Canada

△印は安全部品

Y:PX(Far East, Hawaii)

T:England

E:Europe

Y:AAFES(Europe)

X:Australia

M:Other Areas

△ indicates safety critical components.

PARTS LIST

× New Parts

Parts without Parts No. are not supplied.

Les articles non mentionnés dans le Parts No. ne sont pas fournis.

Teile ohne Parts No. werden nicht geliefert.

TX-RX UNIT (X57-3750-10)

Ref. No. 参照番号	Address 位置	New Parts 新	Parts No. 部品番号	Description 部品名/規格	Desti- nation 仕向	Re- marks 備考
R351			RK73FB2A223J	CHIP R 22K J 1/10W		
R352			R92-0670-05	CHIP R 0 0HM		
R353, 354			RK73FB2A473J	CHIP R 47K J 1/10W		
R355			RK73FB2A472J	CHIP R 4.7K J 1/10W		
R356			RK73FB2A473J	CHIP R 47K J 1/10W		
R357			RK73FB2A472J	CHIP R 4.7K J 1/10W		
R358, 359			R92-0670-05	CHIP R 0 0HM		
R360			RK73FB2A473J	CHIP R 47K J 1/10W		
R361			RK73FB2A102J	CHIP R 1.0K J 1/10W		
R501			RK73FB2A473J	CHIP R 47K J 1/10W		
R502			RK73FB2A562J	CHIP R 5.6K J 1/10W		
R503			RK73FB2A103J	CHIP R 10K J 1/10W		
R504			RK73FB2A105J	CHIP R 1.0M J 1/10W		
R505, 506			RK73FB2A2R2J	CHIP R 2.2 J 1/10W		
R507			RK73FB2A102J	CHIP R 1.0K J 1/10W		
R508-510			RS14DB3F150J	FL-PROOF RS 15 J 3W		
VR101			R12-6738-05	TRIMMING POT. 4.7K		
VR102			R12-6744-05	TRIMMING POT. 47K		
VR301			R12-6742-05	TRIMMING POT. 22K		
VR302, 303			R12-6748-05	TRIMMING POT. 220K		
W101-104			R92-1061-05	JUMPER REST 0 0HM		
W107			R92-1061-05	JUMPER REST 0 0HM		
K501			S51-1420-05	RELAY (SP)		
K502			S76-0401-05	RELAY (PWR)		
D101			02CZ18(X, Y)	DIODE		
D102			1SS181	DIODE		
D103			1SS184	DIODE		
D104			02CZ5.6(X, Y)	DIODE		
D105, 106			1SS184	DIODE		
D107-110			1SS226	DIODE		
D111			1SS184	DIODE		
D112			02CZ15(X, Y)	DIODE		
D301			1SS226	DIODE		
D302			1SV164	DIODE		
D303			1SV166	DIODE		
D304			1SV164	DIODE		
D305			1SV166	DIODE		
D306-308			1SV164	DIODE		
D309			1SS184	DIODE		
D310			1SV164	DIODE		
D311			1SV166	DIODE		
D501, 502			1SS193	DIODE		
D503			1SS184	DIODE		
IC101			TC4013BF	IC(D FLIP-FL0P X2)		
IC102			L78LR05B-FA	IC		
IC103		*	KCE04	IC		
IC104, 105			BU4094BF	IC(SHIFT/STORE REGISTER)		
IC106		*	78312AGF3343BE	IC		
IC107			TC74HC573AF	IC(LATCH)		
IC108		*	27C256BQ-JBY2	IC		
IC109			X24C04PI	IC		
IC301			MC3371D	IC		
IC302			KCB05	IC(DRIVER)		
IC303			BU4094BF	IC(SHIFT/STORE REGISTER)		

L:Scandinavia

K:USA

P:Canada

Y:PX(Far East, Hawaii)

T:England

E:Europe

Y:AAFES(Europe)

X:Australia

M:Other Areas

△ indicates safety critical components.

PARTS LIST

× New Parts

Parts without Parts No. are not supplied.

Les articles non mentionnés dans le Parts No. ne sont pas fournis.

Teile ohne Parts No. werden nicht geliefert.

TX-RX UNIT (X57-3750-10)

VCO/PLL UNIT (X58-3810-10)

Ref. No. 参照番号	Address 位置	New Parts 新	Parts No. 部品番号	Description 部品名 / 規格	Desti- nation 仕 向	Re- marks 備考
IC304 IC501 IC502 Q101,102 Q103,104		*	NJM78L05UA LA4491N UPC78M08H DTA114EK DTD114EK	IC(VOLTAGE REGULATOR/ +5V) IC(AF POWER AMP) IC(VOLTAGE REGULATOR/ +8V) DIGITAL TRANSISTOR DIGITAL TRANSISTOR		
Q105 Q106 Q107 Q108-112 Q114,115			DTC114EK 2SC2712(Y) 2SD1757K DTC114EK DTC114EK	DIGITAL TRANSISTOR TRANSISTOR TRANSISTOR DIGITAL TRANSISTOR DIGITAL TRANSISTOR		
Q116 Q301 Q302 Q303,304 Q305			DTD114EK 3SK184(S) 3SK140(GR) 2SC2714(Y) 2SK208(Y)	DIGITAL TRANSISTOR FET FET TRANSISTOR FET		
Q306 Q307 Q308 Q309-311 Q501			2SB1119S DTC114EK 2SB1119S DTC114EK DTD114EK	TRANSISTOR DIGITAL TRANSISTOR TRANSISTOR DIGITAL TRANSISTOR DIGITAL TRANSISTOR		
TH101 TH301			157-203-55009 157-102-53003	THERMISTER(20K) THERMISTER(1K)		
Z301		*	X58-3810-10 212-6010-05	VCO/PLL UNIT PLASTIC TUBE		
VCO/PLL UNIT (X58-3810-10)						
C1 C2 -4 C5 C6 C7 -9			C92-0004-05 CK73FB1H102K CC73FCH1H220J CC73FCH1H100D CK73FB1H102K	ELECTRO 1.0UF 16WV CHIP C 1000PF K CHIP C 22PF J CHIP C 10PF D CHIP C 1000PF K		
C10 C11 C12 C13 C14			CC73FCH1H100D CK73FB1H102K C92-0004-05 CK73FB1H102K CC73FCH1H470J	CHIP C 10PF D CHIP C 1000PF K ELECTRO 1.0UF 16WV CHIP C 1000PF K CHIP C 47PF J		
C15 C16 C17 ,18 C19 C20			CC73FSL1H101J CK73FB1H102K C92-0004-05 CK73FB1H102K C92-0504-05	CHIP C 100PF J CHIP C 1000PF K ELECTRO 1.0UF 16WV CHIP C 1000PF K CHIP TAN 0.68UF 20WV		
C21 C22 C23 ,24 C25 C26		*	C92-0543-05 C92-0504-05 CK73FB1H102K CK73FB1H471K CC73FCH1H030C	CHIP TAN 3.3UF 10WV CHIP TAN 0.68UF 20WV CHIP C 1000PF K CHIP C 470PF K CHIP C 3PF C		
C51 C52 C53 C54 C55			CK73FB1H102K CC73FCH1H0R5C CC73FCH1H040C CK73FB1H102K CC73FCH1H470J	CHIP C 1000PF K CHIP C 0.5PF C CHIP C 4PF C CHIP C 1000PF K CHIP C 47PF J		
C56 C57 C58			CC73FCH1H070D CC73FCH1H150J CC73FCH1H030C	CHIP C 7PF D CHIP C 15PF J CHIP C 3PF C		

L:Scandinavia

K:USA

P:Canada

Y:PX(Far East, Hawaii)

T:England

E:Europe

Y:AAFES(Europe)

X:Australia

M:Other Areas

△ indicates safety critical components.

PARTS LIST

× New Parts

Parts without Parts No. are not supplied.

Les articles non mentionnés dans le Parts No. ne sont pas fournis.

Teile ohne Parts No. werden nicht geliefert.

VCO/PLL UNIT (X58-3810-10)

Ref. No. 参照番号	Address 位置	New Parts 新	Parts No. 部品番号	Description 部品名 / 規格	Desti- nation 仕向	Re- marks 備考
C59			CK73FB1H102K	CHIP C 1000PF K		
C61			CC73FCH1H040C	CHIP C 4PF C		
C62			CC73FCH1H330J	CHIP C 33PF J		
C63			CC73FCH1H150J	CHIP C 15PF J		
C64			CC73FCH1H180J	CHIP C 18PF J		
C65			CC73FCH1H030C	CHIP C 3PF C		
C66 , 67			CK73FB1H102K	CHIP C 1000PF K		
C68			C92-0004-05	ELECTRO 1.0UF 16WV		
C69 -71			CK73FB1H102K	CHIP C 1000PF K		
C72			CC73FCH1H220J	CHIP C 22PF J		
C73			CK73FB1H102K	CHIP C 1000PF K		
C74			CK73FB1H561K	CHIP C 560PF K		
C75			CC73FSL1H101J	CHIP C 100PF J		
C76			CK73FB1H102K	CHIP C 1000PF K		
TC51			C05-0369-05	TRIMMING CAP(6PF)		
CN1		*	E40-5493-05	PIN CONNECTOR(15P)		
CN51		*	E40-5494-05	PIN CONNECTOR(7P)		
		*	F10-1480-03	SHIELDING PLATE		
L1			L40-1082-48	SMALL FIXED INDUCTOR(.1U)		
L51			L40-1001-48	SMALL FIXED INDUCTOR(10U)		
L52			L34-2369-05	COIL(TX/VC0)		
L53			L40-1001-48	SMALL FIXED INDUCTOR(10U)		
L54			L34-2371-05	COIL(RX/VC0)		
L55			L40-1082-48	SMALL FIXED INDUCTOR(.1U)		
R1 , 2			RK73FB2A221J	CHIP R 220 J 1/10W		
R3			RK73FB2A330J	CHIP R 33 J 1/10W		
R4			RK73FB2A103J	CHIP R 10K J 1/10W		
R5			RK73FB2A562J	CHIP R 5.6K J 1/10W		
R6			RK73FB2A330J	CHIP R 33 J 1/10W		
R7			RK73FB2A471J	CHIP R 470 J 1/10W		
R8			RK73FB2A101J	CHIP R 100 J 1/10W		
R9			RK73FB2A103J	CHIP R 10K J 1/10W		
R10			RK73FB2A562J	CHIP R 5.6K J 1/10W		
R11 , 12			RK73FB2A330J	CHIP R 33 J 1/10W		
R13			RK73FB2A333J	CHIP R 33K J 1/10W		
R14			RK73FB2A104J	CHIP R 100K J 1/10W		
R15			RK73FB2A472J	CHIP R 4.7K J 1/10W		
R16			RK73FB2A562J	CHIP R 5.6K J 1/10W		
R17			RK73FB2A102J	CHIP R 1.0K J 1/10W		
R18			RK73FB2A562J	CHIP R 5.6K J 1/10W		
R19			RK73FB2A473J	CHIP R 47K J 1/10W		
R20			RK73FB2A330J	CHIP R 33 J 1/10W		
R22 , 23			RK73FB2A221J	CHIP R 220 J 1/10W		
R24			RK73FB2A681J	CHIP R 680 J 1/10W		
R25			RK73FB2A101J	CHIP R 100 J 1/10W		
R26			RK73FB2A103J	CHIP R 10K J 1/10W		
R27 , 28			R92-0670-05	CHIP R 0 OHM		
R29			RK73FB2A100J	CHIP R 10 J 1/10W		
R30			RK73FB2A101J	CHIP R 100 J 1/10W		
R31			RK73FB2A104J	CHIP R 100K J 1/10W		
R51			RK73FB2A473J	CHIP R 47K J 1/10W		
R52			RK73FB2A101J	CHIP R 100 J 1/10W		
R53			RK73FB2A473J	CHIP R 47K J 1/10W		

L:Scandinavia

K:USA

P:Canada

Y:PX(Far East, Hawaii)

T:England

E:Europe

Y:AAFES(Europe)

X:Australia

M:Other Areas

△ indicates safety critical components.

TK-730H(B)

PARTS LIST

× New Parts

Parts without Parts No. are not supplied.

Les articles non mentionnés dans le Parts No. ne sont pas fournis.

Teile ohne Parts No. werden nicht geliefert.

VCO/PLL UNIT (X58-3810-10)

Ref. No. 参照番号	Address 位置	New Parts 新	Parts No. 部品番号	Description 部品名 / 規格	Desti- nation 仕向	Re- marks 備考
R54			RK73FB2A271J	CHIP R 270 J 1/10W		
R55			RK73FB2A330J	CHIP R 33 J 1/10W		
R56			RK73FB2A101J	CHIP R 100 J 1/10W		
R57			RK73FB2A562J	CHIP R 5.6K J 1/10W		
R58			RK73FB2A271J	CHIP R 270 J 1/10W		
R59			RK73FB2A562J	CHIP R 5.6K J 1/10W		
R60			RK73FB2A103J	CHIP R 10K J 1/10W		
R61			RK73FB2A221J	CHIP R 220 J 1/10W		
R62			RK73FB2A331J	CHIP R 330 J 1/10W		
R63			RK73FB2A330J	CHIP R 33 J 1/10W		
R64			RK73FB2A472J	CHIP R 4.7K J 1/10W		
R65			RK73FB2A104J	CHIP R 100K J 1/10W		
R66			RK73FB2A153J	CHIP R 15K J 1/10W		
D1			MA77	DIODE		
D51			1SV164	DIODE		
D52 -55			1T33C	DIODE		
ICI			MB1504PF	IC		
Q1 , 2			2SC2714(Y)	TRANSISTOR		
Q3			2SA1162(Y)	TRANSISTOR		
Q4			DTC143EK	DIGITAL TRANSISTOR		
Q5			2SA1312(GR)	TRANSISTOR		
Q6			2SC3324(G)	TRANSISTOR		
Q51 , 52			2SK508NV(K52)	FET		
Q53			2SC2714(Y)	TRANSISTOR		
Q54			DTC114EK	DIGITAL TRANSISTOR		
Q55			FMG2	TRANSISTOR		

L:Scandinavia

K:USA

P:Canada

Y:PX(Far East, Hawaii)

T:England

E:Europe

Y:AAFES(Europe)

X:Australia

M:Other Areas

 indicates safety critical components.

PARTS LIST

× New Parts

Parts without Parts No. are not supplied.

Les articles non mentionnés dans le Parts No. ne sont pas fournis.

Teile ohne Parts No. werden nicht geliefert.

KCH-3

DISPLAY UNIT (X54-3100-20)

Ref. No. 参照番号	Address 位置	New Parts 新	Parts No. 部品番号	Description 部品名/規格	Desti- nation 仕向	Re- marks 備考
KCH-3						
201	2C	*	A22-0776-02	SUB PANEL		
202	1C	*	A62-0063-03	PANEL		
		*	A62-0064-03	PANEL ASSY		
205	2C	*	B10-1162-04	FRONT GLASS		
			B42-3317-04	LABEL(S/NO)		
		*	E37-0157-05	CONNECTING WIRE		
		*	E37-0159-05	CONNECTING WIRE		
211	1C		G09-0405-05	SPRING		
212	1C		G53-0509-04	PACKING		
214	2J	*	H10-2725-02	POLYSTYRENE FOAMED FIXTURE		
215	1I	*	H11-0847-04	POLYSTYRENE PLATE		
216	1J	*	H13-0854-04	PACKING FIXTURE		
217	2I		H25-0103-04	PROTECTION BAG		
218	3I	*	H52-0108-04	ITEM CARTON BOX		
220	3D	*	J21-4340-04	MOUNTING HARDWARE		
222	2C	*	K29-4663-02	KEY TOP		
223	1C	*	K29-4664-04	KNOB (VOL,CH)		
H	3C		N87-2606-46	BRAZIER HEAD TAPTITE SCREW		
J	3C, 3D		N87-3008-46	BRAZIER HEAD TAPTITE SCREW		
225	2J		N99-0364-05	SCREW SET		
227	3D		T07-0247-05	LOUDSPEAKER(FULLRANGE)		
229	3C	*	X54-3100-20	DISPLAY UNIT		
			212-3302-05	PLASTIC TUBE		
DISPLAY UNIT (X54-3100-20)						
D6			B38-0322-05	LED ASSY		
ED1		*	B38-0353-05	LCD		
C1 -4			CC73FSL1H101J	CHIP C 100PF K		
C5			CC73FSL1H101J	CHIP C 100PF J		
C6 -11			CK73FB1H102K	CHIP C 1000PF K		
C12			CC73FSL1H101J	CHIP C 100PF J		
C13			CK73FB1H102K	CHIP C 1000PF K		
C14 ,15			CC73FSL1H101J	CHIP C 100PF J		
C16 -20			CK73FB1H102K	CHIP C 1000PF K		
C21 -25			CC73FSL1H101J	CHIP C 100PF J		
C26 ,27			CK73FB1H102K	CHIP C 1000PF K		
C28			C92-0003-05	CHIP TAN 0.47UF 25WV		
C29			CK73FB1H102K	CHIP C 1000PF K		
C30			C92-0038-05	ELECTRO 22UF 16WV		
C31			CK73FB1E103K	CHIP C 0.01UF K		
C32 ,33			CC73FSL1H101J	CHIP C 100PF J		
CN1		*	E29-0497-04	CONNECTOR		
CN2			E40-3241-05	PIN CONNECTOR(6P)		
CN3			E40-3255-05	PIN CONNECTOR(11P)		
CN4			E40-3247-05	PIN CONNECTOR(3P)		
			E40-3237-05	PIN CONNECTOR(2P)		
J1			E08-0673-05	RECTANGULAR RECEPTACLE(MIC)		
W1		*	E37-0118-05	CONNECTING WIRE		

L:Scandinavia

K:USA

P:Canada

Y:PX(Far East, Hawaii)

T:England

E:Europe

Y:AAFES(Europe)

X:Australia

M:Other Areas

⚠ indicates safety critical components.

PARTS LIST

× New Parts

Parts without Parts No. are not supplied.

Les articles non mentionnés dans le Parts No. ne sont pas fournis.

Teile ohne Parts No. werden nicht geliefert.

DISPLAY UNIT (X54-3100-20)

Ref. No. 参照番号	Address 位置	New Parts 新	Parts No. 部品番号	Description 部品名 / 規格	Desti- nation 仕向	Re- marks 備考
			G13-0656-04	CUSHION		
		*	J21-4343-04	MOUNTING HARDWARE		
X1			L78-0043-05	RESONATOR(4.19MHZ)		
R1 ,2			RK73FB2A102J	CHIP R 1.0K J 1/10W		
R3			RK73FB2A681J	CHIP R 680 J 1/10W		
R4			RK73FB2A821J	CHIP R 820 J 1/10W		
R5			RK73FB2A561J	CHIP R 560 J 1/10W		
R6		*	R92-1281-05	FIXED RESISTOR 4.7		
R7			RK73FB2A820J	CHIP R 82 J 1/10W		
R8 -13			RK73FB2A102J	CHIP R 1.0K J 1/10W		
R14			RK73FB2A473J	CHIP R 47K J 1/10W		
R15 ,16			RK73FB2A101J	CHIP R 100 J 1/10W		
R17			RK73FB2A181J	CHIP R 180 J 1/10W		
R18			R92-0670-05	CHIP R 0 0HM		
R19			RK73FB2A472J	CHIP R 4.7K J 1/10W		
R20			R92-0670-05	CHIP R 0 0HM		
VR1		*	R05-3457-05	POTENTIOMETER(10KA)		
S1			S40-1420-05	PUSH SWITCH		
S2 -5		*	S70-0410-05	TACT SWITCH		
D1 -4			1SS226	DIODE		
D5			1SS181	DIODE		
IC1		*	75328GC5563B9	IC		
IC2			L78LR05B-FA	IC		
Q1			DTD114EK	DIGITAL TRANSISTOR		
Q2			DTC114EK	DIGITAL TRANSISTOR		
S10			W02-0393-05	ENCORDER		

L:Scandinavia

K:USA

P:Canada

Y:PX(Far East, Hawaii)

T:England

E:Europe

Y:AAFES(Europe)

X:Australia

M:Other Areas

 indicates safety critical components.

PARTS LIST

× New Parts

Parts without Parts No. are not supplied.

Les articles non mentionnés dans le Parts No. ne sont pas fournis.

Teile ohne Parts No. werden nicht geliefert.

KCH-4

DISPLAY UNIT (X54-3110-20)

Ref. No. 参照番号	Address 位置	New Parts 新	Parts No. 部品番号	Description 部品名 / 規格	Desti- nation 仕 向	Re- marks 備考
KCH-4						
301	2E	*	A22-0777-02	SUB PANEL		
302	1E	*	A62-0066-03	PANEL		
		*	A62-0067-03	PANEL ASSY		
305	2F	*	B10-1163-04	FRONT GLASS		
			B42-3317-04	LABEL (S/NØ)		
308	1E		G09-0405-05	SPRING		
310	2L	*	H10-2725-02	POLYSTYRENE FOAMED FIXTURE		
311	1K	*	H11-0847-04	POLYSTYRENE PLATE		
312	1L	*	H13-0854-04	PACKING FIXTURE		
313	2L		H25-0029-04	PROTECTION BAG		
314	2L		H25-0096-04	PROTECTION BAG		
315	2K		H25-0103-04	PROTECTION BAG		
316	3K	*	H52-0109-04	ITEM CARTON BOX		
318	1E	*	K29-4664-04	KNØB(VØL,CH)		
319	2E	*	K29-4666-02	KEY TOP		
320	2L	*	K29-4704-04	KNØB ASSY		
K	3E, 3F		N87-2606-46	BRAZIER HEAD TAPTITE SCREW		
L	3E, 3F		N87-3008-46	BRAZIER HEAD TAPTITE SCREW		
322	2L		N99-0364-05	SCREW SET		
324	3E, 3F	*	X54-3110-20	DISPLAY UNIT		
DISPLAY UNIT (X54-3110-20)						
D7		*	B38-0352-05	LED ASSYASSY		
ED1		*	B38-0354-05	LCD		
C1 -5			CC73FSL1H101J	CHIP C 100PF J		
C6 -11			CK73FB1H102K	CHIP C 1000PF K		
C12			CC73FSL1H101J	CHIP C 100PF J		
C13			CK73FB1H102K	CHIP C 1000PF K		
C14 ,15			CC73FSL1H101J	CHIP C 100PF J		
C16 -20			CK73FB1H102K	CHIP C 1000PF K		
C21 -25			CC73FSL1H101J	CHIP C 100PF J		
C26 ,27			CK73FB1H102K	CHIP C 1000PF K		
C28			C92-0003-05	CHIP TAN 0.47UF 25WV		
C29			C92-0038-05	ELECTRØ 22UF 16WV		
C30			CK73FB1H102K	CHIP C 1000PF K		
C31			CK73FB1E103K	CHIP C 0.01UF K		
C32 -37			CC73FSL1H101J	CHIP C 100PF J		
CN1		*	E02-2010-05	TRANSISTØR SØCKET		
CN2			E29-0496-04	CØNNECTØR		
CN3			E40-3241-05	PIN CØNNECTØR(6P)		
			E40-3255-05	PIN CØNNECTØR(11P)		
			E40-3247-05	PIN CØNNECTØR(3P)		
J1		*	E08-0673-05	RECTANGULAR RECEPTACLE(MIC)		
W1		*	E37-0118-05	CØNNECTING WIRE		
			G13-1353-04	CUSHION		
		*	J21-4342-04	MØUNTING HARDWARE		
X1			L78-0043-05	RESØNATØR(4.19MHZ)		

L:Scandinavia

K:USA

P:Canada

Y:PX(Far East, Hawaii)

T:England

E:Europe

Y:AAFES(Europe)

X:Australia

M:Other Areas

△ indicates safety critical components.

TK-730H(B)

PARTS LIST

× New Parts

Parts without Parts No. are not supplied.

Les articles non mentionnés dans le Parts No. ne sont pas fournis.

Teile ohne Parts No. werden nicht geliefert.

DISPLAY UNIT (X54-3110-20)

Ref. No. 参照番号	Address 位置	New Parts 新	Parts No. 部品番号	Description 部品名 / 規格	Desti- nation 仕向	Re- marks 備考
R1 ,2			RK73FB2A102J	CHIP R 1.0K J 1/10W		
R3			RK73FB2A681J	CHIP R 680 J 1/10W		
R4			RK73FB2A821J	CHIP R 820 J 1/10W		
R5			RK73FB2A561J	CHIP R 560 J 1/10W		
R6		*	R92-1281-05	FIXED RESISTOR 4.7		
R7			RK73FB2A821J	CHIP R 820 J 1/10W		
R8 -13			RK73FB2A102J	CHIP R 1.0K J 1/10W		
R14			RK73FB2A473J	CHIP R 47K J 1/10W		
R15 ,16		*	R92-1280-05	FIXED RESISTOR 390		
R17 ,18			RK73FB2A181J	CHIP R 180 J 1/10W		
R19 ,20			RK73FB2A152J	CHIP R 1.5K J 1/10W		
R21 ,22			RK73EB2B471J	CHIP R 470 J 1/8W		
R23 -26			RK73FB2A102J	CHIP R 1.0K J 1/10W		
R27 ,28			RK73FB2A473J	CHIP R 47K J 1/10W		
R29 -32			RK73FB2A101J	CHIP R 100 J 1/10W		
R33			R92-0670-05	CHIP R 0 OHM		
R34			RK73FB2A103J	CHIP R 10K J 1/10W		
R35			R92-0670-05	CHIP R 0 OHM		
R36			RK73FB2A473J	CHIP R 47K J 1/10W		
VR1		*	R05-3457-05	POTENTIOMETER(10KA)		
S1			S40-1420-05	PUSH SWITCH		
S2 -9		*	S70-0410-05	TACT SWITCH		
D1 -4			1SS226	DIODE		
D5			1SS181	DIODE		
D6			02CZ10(X,Y)	DIODE		
IC1			753286C5563B9	IC		
IC2			L78LR05B-FA	IC		
IC3		*	X24C04PI	IC		
IC4			MSM5265GS-V1K	IC(LCD DRIVER)		
Q1			DTD114EK	DIGITAL TRANSISTOR		
Q2			2SC2873(Y)	TRANSISTOR		
Q3			FMC5	TRANSISTOR		
S10			W02-0393-05	ENCORDER		

L:Scandinavia

K:USA

P:Canada

Y:PX(Far East, Hawaii)

T:England

E:Europe

Y:AAFES(Europe)

X:Australia

M:Other Areas

△ indicates safety critical components.

EXPLODED VIEW

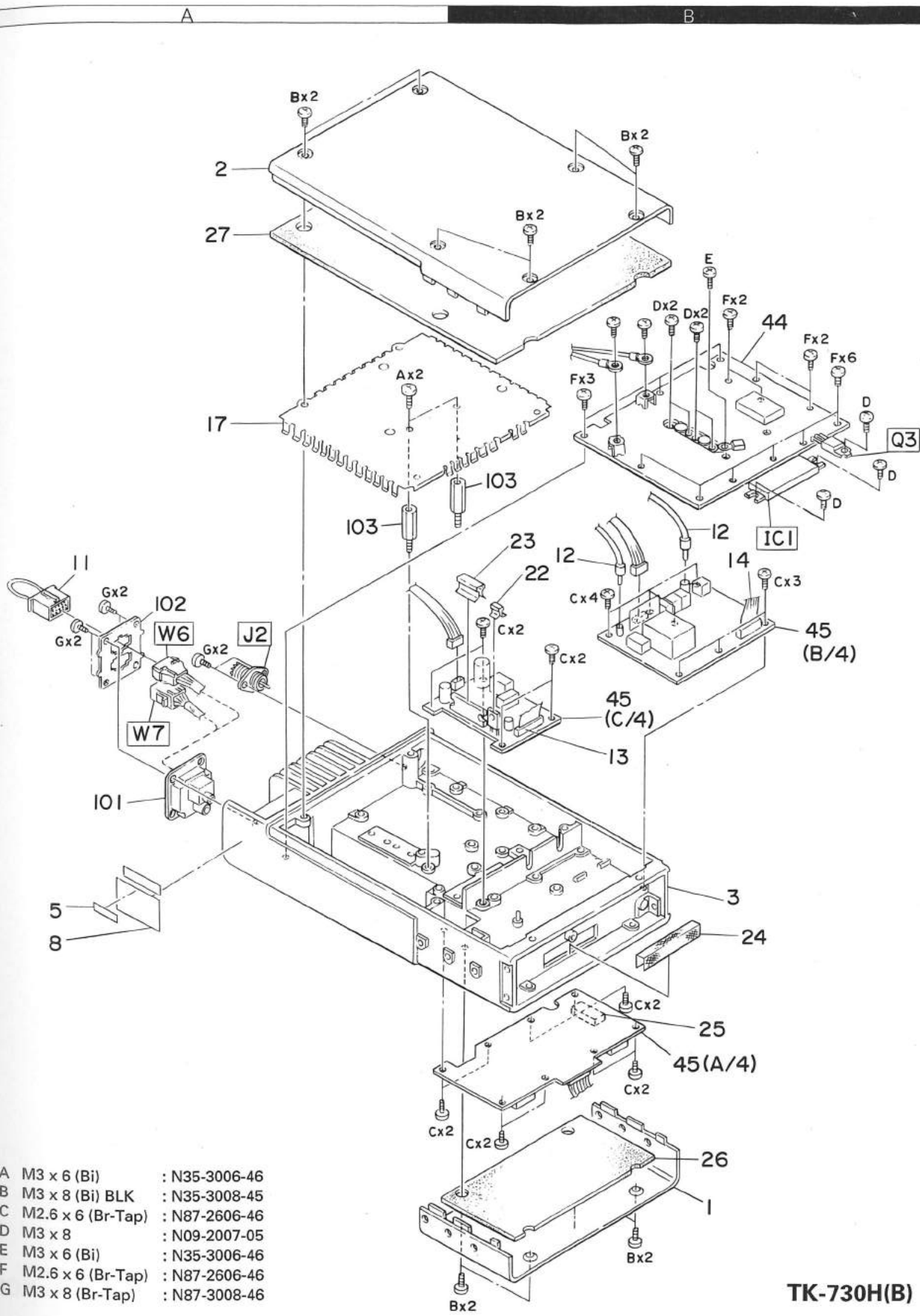

- | | | |
|---|-------------------|---------------|
| A | M3 x 6 (Bi) | : N35-3006-46 |
| B | M3 x 8 (Bi) BLK | : N35-3008-45 |
| C | M2.6 x 6 (Br-Tap) | : N87-2606-46 |
| D | M3 x 8 | : N09-2007-05 |
| E | M3 x 6 (Bi) | : N35-3006-46 |
| F | M2.6 x 6 (Br-Tap) | : N87-2606-46 |
| G | M3 x 8 (Br-Tap) | : N87-3008-46 |

TK-730H(B)

TK-730H(B)

EXPLODED VIEW

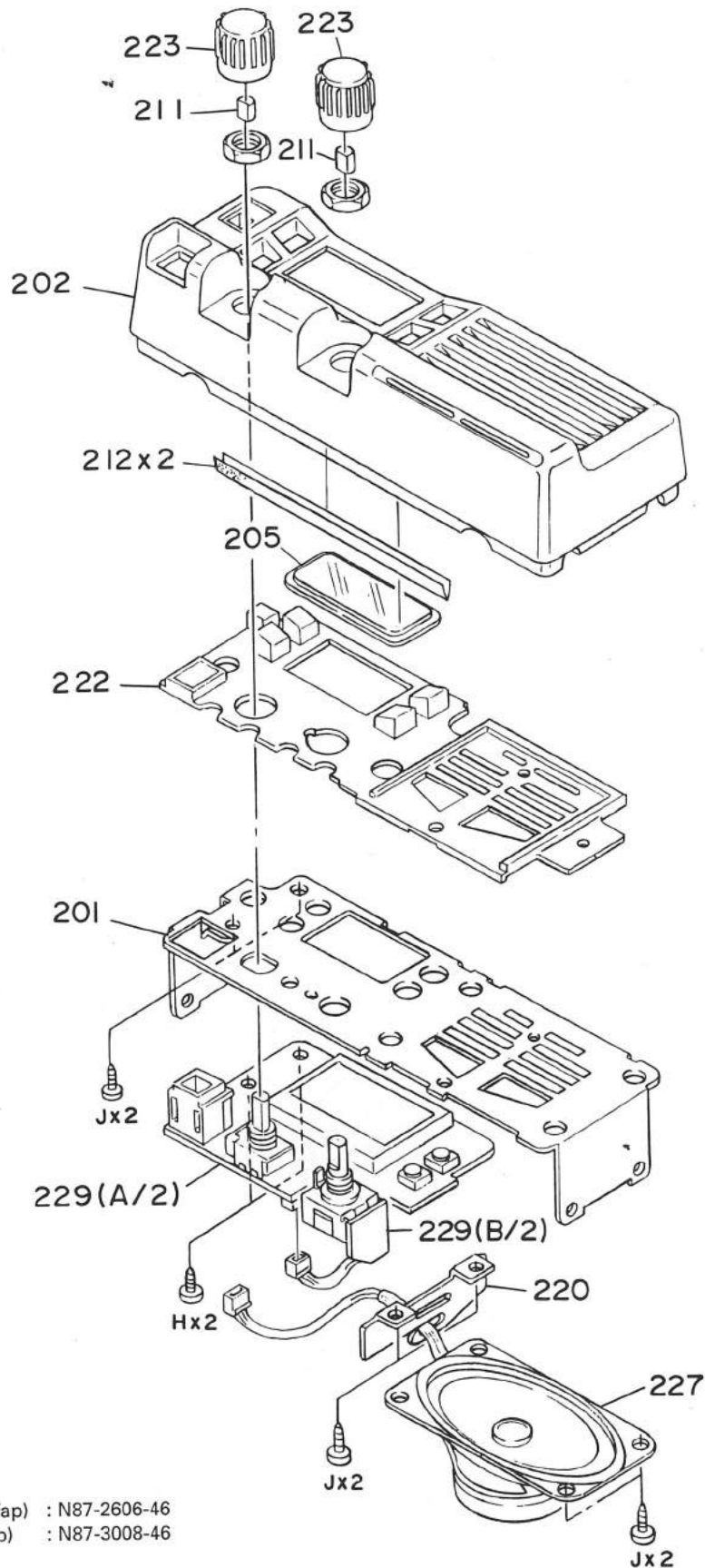

H M2.6 x 6 (Br-Tap) : N87-2606-46
J M3 x 8 (Br-Tap) : N87-3008-46

KCH-3

EXPLODED VIEW

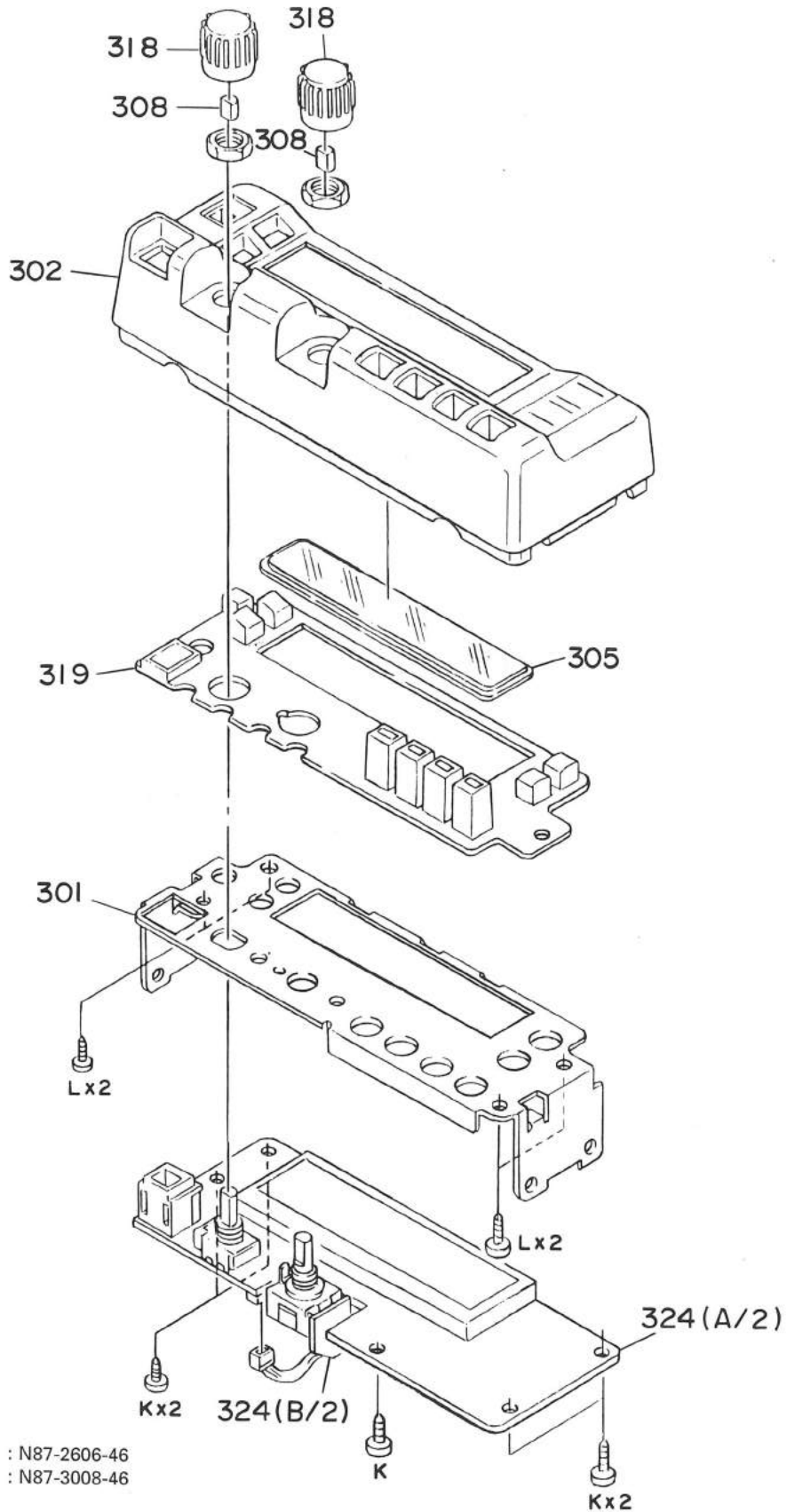

K M2.6 x 6 (Br-Tap) : N87-2606-46
 L M3 x 8 (Br-Tap) : N87-3008-46

KCH-4

PACKING

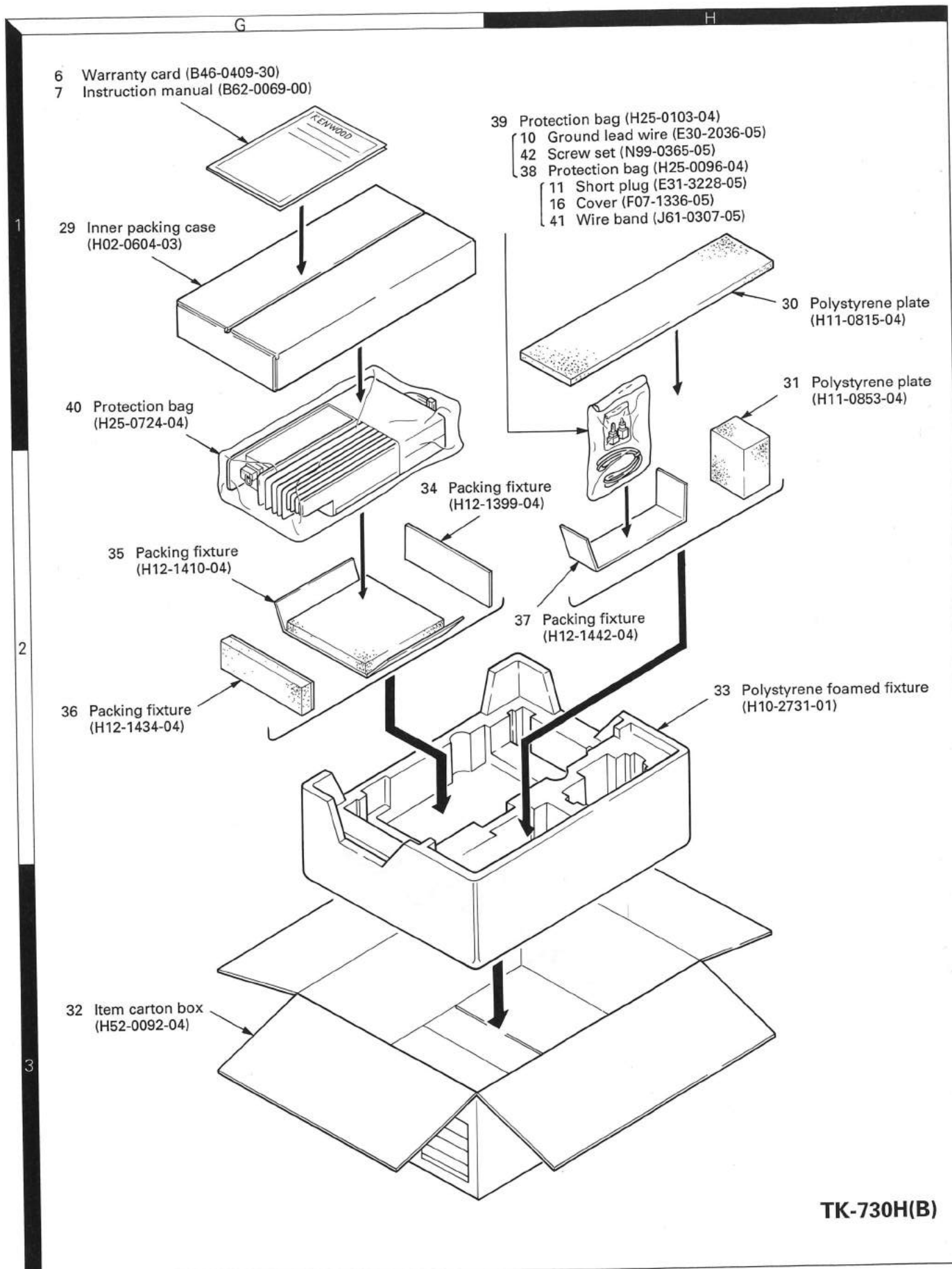

PACKING

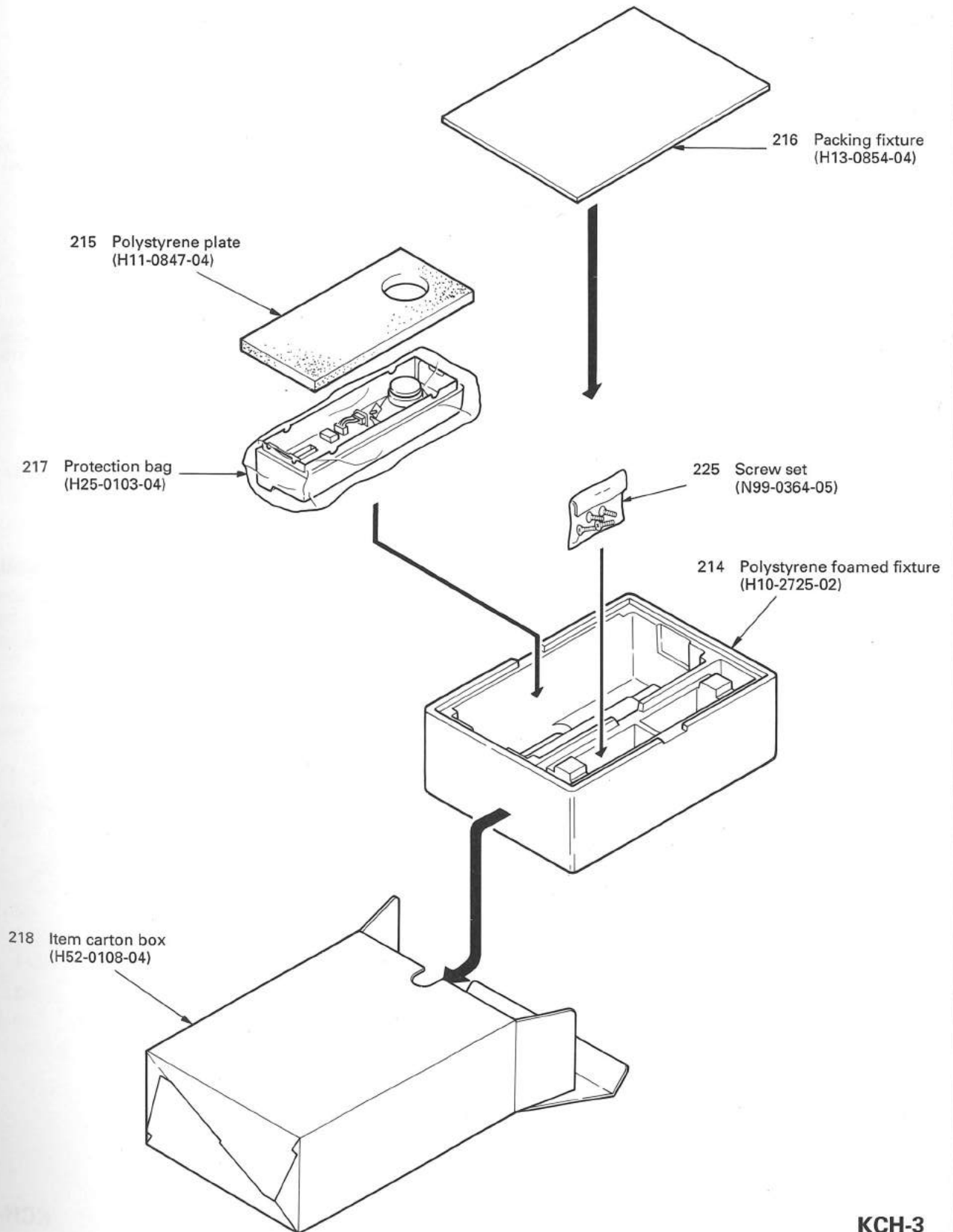

KCH-3

PACKING

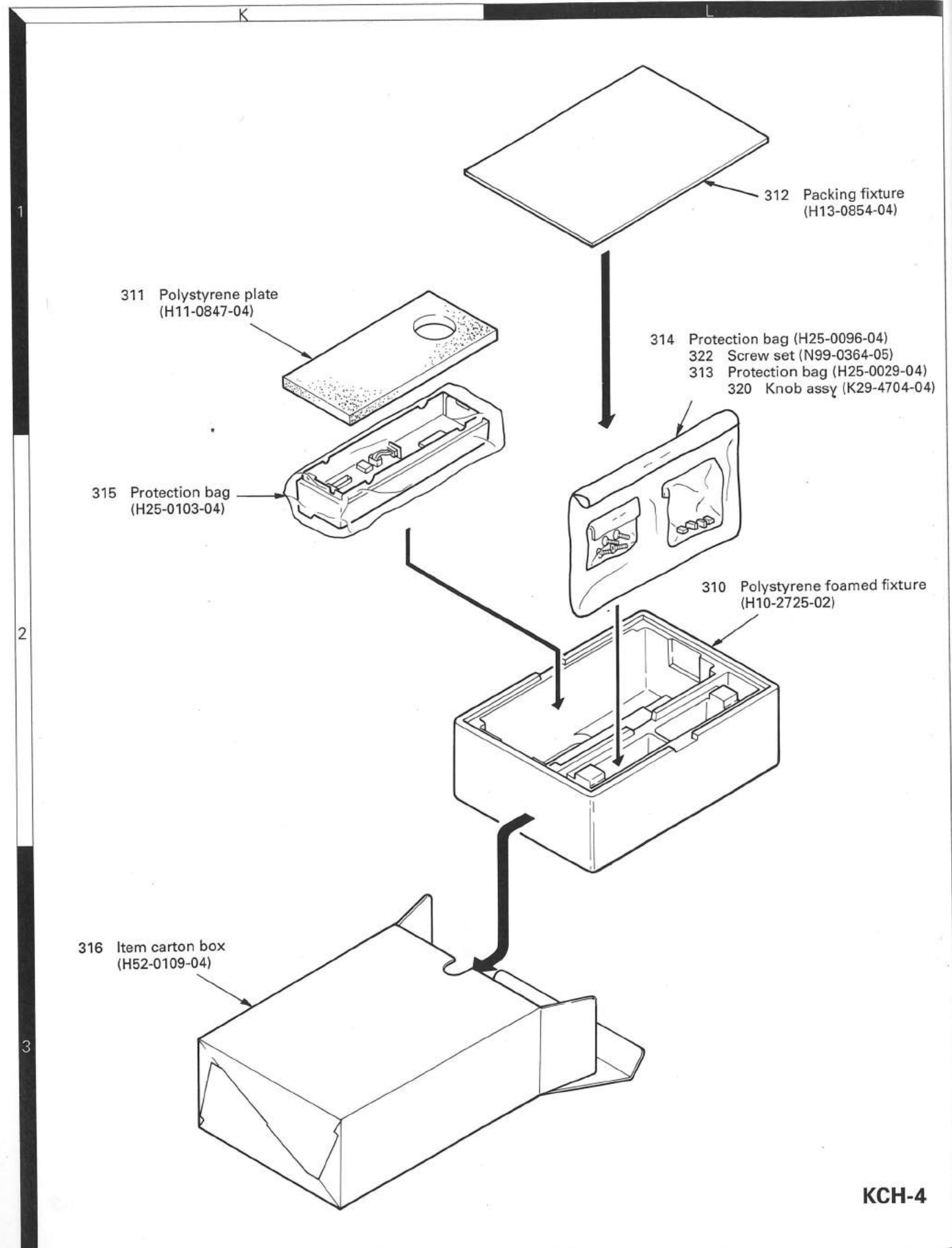

KCH-4

ADJUSTMENT

Test Equipment Required for Alignment

No.	Test Equipment	Major Specifications
1	Standard Signal Generator (SSG)	Frequency Range: 150 to 174MHz. Modulation: Frequency modulation and external modulation. Output: 0.1μV to greater than 1mV.
2	Power Meter	Input Impedance: 50Ω. Operation Frequency: 150 to 174MHz or more. Measurement Capability: Vicinity of 200W.
3	Deviation Meter	Frequency Range: 150 to 174MHz.
4	Digital Volt Meter (DVM)	Measuring Range: 1 to 20V DC. Accuracy: High input impedance for minimum circuit loading.
5	Oscilloscope	DC through 30MHz.
6	High Sensitivity Frequency Counter	Frequency Range: 10Hz to 200MHz. Frequency Stability: 0.2ppm or less.
7	Ammeter	30A.
8	AF Volt Meter (AFVTVM)	Frequency Range: 50Hz to 10kHz. Voltage Range: 3mV to 3V.
9	Audio Generator (AG)	Frequency Range: 50Hz to 5kHz or more. Output: 0 to 1V.
10	Distortion Meter	Capability: 3% or less at 1kHz. Input Level: 50mV to 10Vrms.
11	Voltmeter	Measuring Range: 10 to 1.5V DC or less. Input Impedance: 50kΩ/V or greater.
12	4Ω Dummy Load	Approx. 4Ω, 30W.
13	Regulated Power Supply	13.4V, approx. 30A (adjustable from 9 to 17 V). Useful if ammeter equipped.

Caution

Since the RX AF output is a BTL output, there is a DC component. Isolate this with a capacitor or transformer as shown in the figure.

MIC connector front view

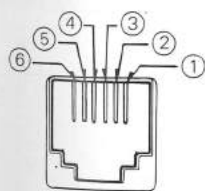

- ① SB
- ② PTTG
- ③ PTT
- ④ MICG
- ⑤ MIC
- ⑥ HOOK

- The following test cables are recommended.

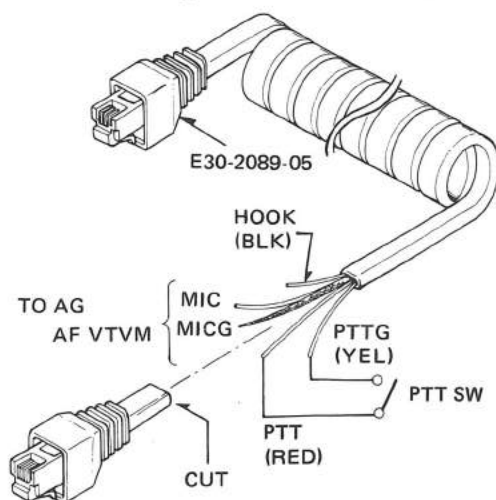

Test cable for Microphone input

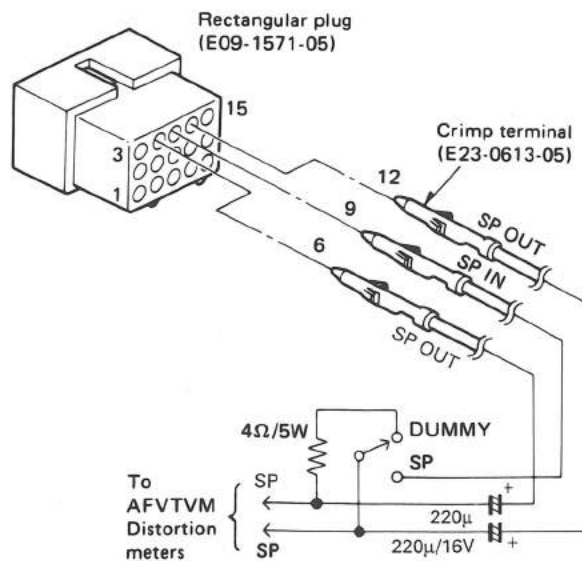

Test cable for Speaker output

TK-730H(B)

ADJUSTMENT

Adjustment Points

• Upper side

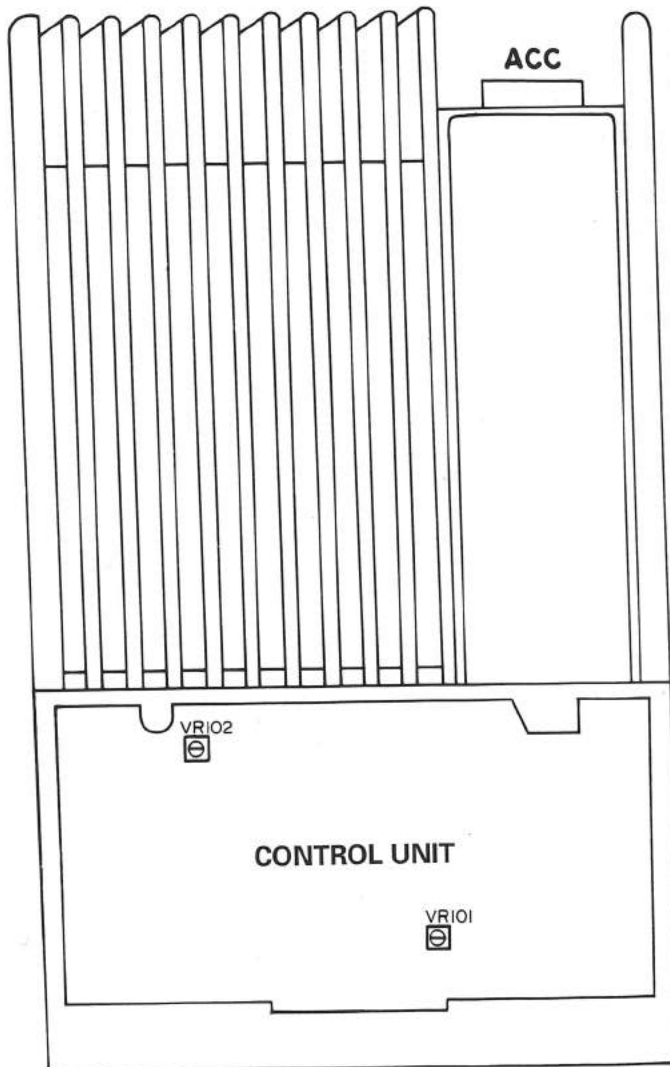

CONTROL UNIT
 VR101 : MIC sensitivity
 VR102 : Squelch

• Lower side

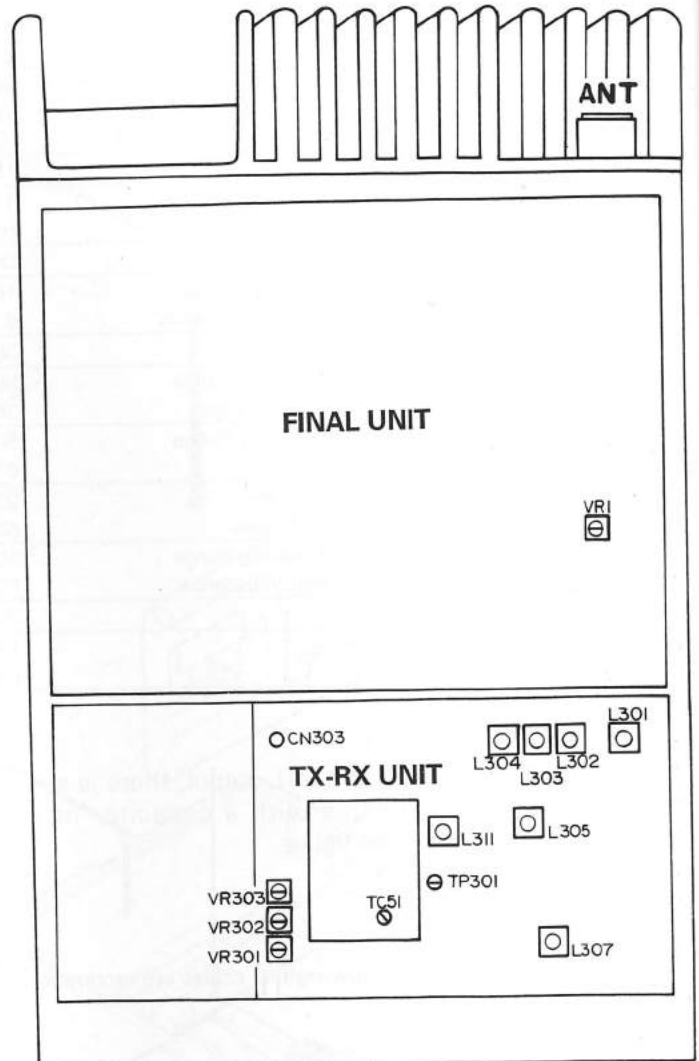

TX-RX UNIT
 L301~304, 311 : BPF
 L305, 307 : Distortion
 VR301 : Maximum deviation
 VR302 : DQT
 VR303 : QT

VCO/PLL
 TC51 : PLL lock voltage

FINAL UNIT
 VR1 : Power (APC)

ADJUSTMENT

The set has been adjusted for the frequencies shown in the following table.

When required, re-adjust them following the adjustment procedure to obtain the frequencies you want in actual operation.

Test mode

		K
CH1	fTX1 (MHz)	162.000
	fRX1 (MHz)	162.060
	TONE	-
CH2	fTX2 (MHz)	150.000
	fRX2 (MHz)	150.060
	TONE	-
CH3	fTX3 (MHz)	173.970
	fRX3 (MHz)	173.940
	TONE	-
CH4	fTX4 (MHz)	162.000
	fRX4 (MHz)	162.000
	TONE	DQT 754N

		K
CH5	fTX5 (MHz)	162.000
	fRX5 (MHz)	162.000
	TONE	QT 151.4Hz
CH6	fTX6 (MHz)	162.000
	fRX6 (MHz)	162.000
	TONE	QT 67.0Hz
CH7	fTX7 (MHz)	162.000
	fRX7 (MHz)	162.000
	TONE	QT 210.7Hz
CH8	fTX8 (MHz)	161.010
	fRX8 (MHz)	161.010
	TONE	-

		K
CH9	fTX9 (MHz)	154.980
	fRX9 (MHz)	154.980
	TONE	QT 131.2Hz
CH10	fTX10 (MHz)	154.980
	fRX10 (MHz)	154.980
	TONE	DQT 023N
CH11	fTX11 (MHz)	154.980
	fRX11 (MHz)	154.980
	TONE	QT 100Hz
CH12	fTX12 (MHz)	154.980
	fRX12 (MHz)	154.980
	TONE	DQT 444N

The set frequency is subject to change without prior notice.

Alignment

Item	Condition	Measurement			Adjustment			Specifications/Remarks
		Test-equipment	Unit	Terminal	Unit	Parts	Method	
1. Setting	1) Connect the front panel (KCH-4) to the TK-730H(B). 2) Front panel VR : MIN 3) Write in frequency designed with EEPROM writer. 4) Connect the power cable to the rear panel. 5) TX-RX unit VR301 and VR303 : Center 6) Power SW : ON							

TK-730H(B)

ADJUSTMENT

Item	Condition	Measurement			Adjustment			Specifications/Remarks
		Test-equipment	Unit	Terminal	Unit	Parts	Method	
2. PLL lock voltage	1) CH : CH3 Receive	DVM	TX-RX	TP301	TX-RX	TC51 (Z301)	6.8V ADJ.	±0.1V
	2) CH : CH3 Transmit (PTT : ON)						Check	4.7~5.7V
	3) CH : CH2 Receive							1.8~2.5V
	4) CH : CH2 Transmit (PTT : ON)							1.7~2.7V
3. Transmit frequency check	1) CH : CH1 ANT : Power meter PTT : ON	Power meter f. counter	Rear panel	ANT			Check	$f_{TX} \pm 243\text{Hz}$
4. Power adjustment (APC)	1) CH : CH1 PTT : ON	Power meter Ammeter	Rear panel	ANT	Final	VR1	MAX CW	120W or more
							MAX CCW	45W or less
	110W ADJ.						±5W, 25A or less	
	2) CH : CH2, CH3 - PTT : ON						Check	94~126W 25A or less
5. DQT	1) CH : CH4 Deviation meter filter HPF : OFF LPF : 3kHz De-emphasis : OFF PTT : ON	Power meter Deviation meter Oscilloscope	Rear panel	ANT	TX-RX	VR302	Make the demodulation waveform neat.	
6. QT	1) CH : CH5 Deviation meter filter HPF : 50Hz LPF : 3kHz De-emphasis : 750μS PTT : ON							
7. Maximum deviation adjustment	1) CH : CH1 Connect AG to the MIC terminal. AG : 1kHz/50mV Deviation meter filter HPF : OFF LPF : 15kHz De-emphasis : 750μs PTT : ON	Power meter Deviation meter AF VTVM AG Oscilloscope	Rear panel	ANT	TX-RX	VR301	±4.2kHz Adjust one more than the other by switching between -P and +P.	±100Hz
8. MIC sensitivity adjustment	1) CH : CH1 Deviation meter filter HPF : OFF LPF : 15kHz De-emphasis : 750μs (P-P)/2 AG : 1kHz/5mV PTT : ON							

ADJUSTMENT

Item	Condition	Measurement			Adjustment			Specifications/Remarks
		Test-equipment	Unit	Terminal	Unit	Parts	Method	
9. Distortion adjustment	1) CH : CH1 SSG frequency : frx1 output : : 500 μ V/54dB μ -53dBm MOD : 1kHz DEV : \pm 3kHz AF : 1.4V/4 Ω	SSG AF VTVM Distortion meter Oscilloscope 4 Ω dummy load	Rear panel	ANT ACC (EXT.SP)	TX-RX	L305	Adjust for minimum distortion.	Distortion : 3% or less
						L307	Adjust for maximum AF output.	
10. BPF adjustment	1) CH : CH1 SSG frequency : frx1 output : : 0.20 μ V/-14dB μ -121dBm MOD : 1kHz DEV : \pm 3kHz	SSG Distortion meter Oscilloscope AF VTVM	Rear panel	ANT ACC (EXT.SP)	TX-RX	L311	Adjust for maximum SINAD.	
						L304 ↓ L303 ↓ L302 ↓ L301		
						L302	Turn the core counterclockwise (1 turn).	
11. Sensitivity adjustment	1) CH : CH1~CH3 SSG frequency : frx1~frx3 output : : 0.25 μ V/-12dB μ -119dBm MOD : 1kHz DEV : \pm 3kHz						Check	SINAD 12dB or more
12. Squelch adjustment	1) CH : CH1 SSG frequency : frx1 Output : Value when 3dB is subtracted from the sensitivity value of 12dB SINAD. MOD : 1kHz DEV : \pm 3kHz	SSG Distortion meter Oscilloscope	Rear panel	ANT ACC (EXT.SP)	CONT	VR102	Set to threshold point.	
	2) SSG output : 8dB SINAD						Check	Squelch open
	3) SSG output : OFF							Squelch close

TERMINAL FUNCTIONS

Connector No.	Terminal No.	Terminal Name	I/O	Terminal Function
FINAL UNIT (X45-3390-10)				
CN1 To TX-RX unit	1	RA	O	Receiver signal output, coaxial connector.
CN2 To TX-RX unit	1	DO	I	Transmission signal input, coaxial connector. (200mW)
CN3	1	B	I	Power supply input. (13.4V ± 15%)
CN4	1	E	-	Earth.
W1 To AF unit	1	E	-	Earth.
	2	B	O	Power supply output. (13.4V ± 15%)
	3	B	O	Power supply output. (13.4V ± 15%)
W2 To TX-RX unit	1	DB	O	Transmission drive control voltage output. (APC)
	2	E	-	Earth.
	3	8R	I	8V input during reception.
	4	8T	I	8V input during transmission.
CONTROL UNIT (X57-3750-10) (A/3)				
CN101 To AF unit	1	8C	I	Common 8V. (8V ± 5%)
	2	SB	I	Power input after power switch. (13.4V ± 15%)
	3	SB	I	Power input after power switch. (13.4V ± 15%)
	4	SB	I	Power input after power switch. (13.4V ± 15%)
	5	PSB	I	Power input. (unswitched)
	6	PSC	O	Controls power switch relay. (Power SW ON : "L", OFF : "H")
	7	AFO	O	Audio output.
	8	SSC	O	Controls SPEAKER select relay.
	9	E	-	Earth.
	10	E	-	Earth.
	11	RS1	I	Input for remote speaker 1. (BTL 4W)
	12	CSP	I	Input for common speaker. (BTL 13W)
	13	CSP	I	Input for common speaker. (BTL 13W)
	14	ES1	I	Input for external speaker A. (BTL 13W)
	15	ES1	I	Input for external speaker A. (BTL 13W)
	16	OS1	I	Input for external speaker B. (BTL 13W)
	17	OS1	I	Input for external speaker B. (BTL 13W)
CN102 To TX-RX unit	1	DP	O	DATA output for PLL.
	2	EP	O	ENABLE output for PLL.
	3	CP	O	CLOCK output for PLL.
	4	LD	I	LOCK detect input for PLL. "H" : LOCK, "L" : UNLOCK
	5	TO	O	TONE signal output.
	6	ES	O	ENABLE output for shift register.
	7	MO	O	Modulation signal output.
	8	8C	O	Common 8V. (8V ± 5%)
	9	E	-	Earth.
	10	8C	O	Common 8V. (8V ± 5%)
	11	DET	I	Detection signal input.
	12	NC	-	Not use.
	13	NC	-	Not use.
CN103 To control cable	1	E	-	Earth.
	2	DP	O	DATA output for PLL.
	3	CP	O	CLOCK output for PLL.
	4	EI	O	ENABLE interface output.
	5	DD2	I/O	DATA input/output for HEAD 2.
	6	CD2	O	CLOCK output for HEAD 2.
	7	TXD	O	TX DATA output for HEAD 1.
	8	RXD	I	RX DATA input for HEAD 2.

Connector No.	Terminal No.	Terminal Name	I/O	Terminal Function
	9	BZ2	O	Beep output for HEAD 2.
	10	5C	O	Common 5V. (5V ± 5%)
	11	DE3	O	Detection signal output for HEAD 2.
CN104 To ACC connector	1	MIC	I/O	MIC signal input/output.
	2	ME	-	MIC earth.
	3	DEO	O	Detection signal output.
	4	E	-	Earth.
	5	HN1	O	Horn alert signal output.
	6	HN2	O	Horn alert signal output.
	7	IGN	I	Ignition input.
	8	OS1	O	Input for external speaker B. (BTL 13W)
CN105 To ACC connector	1	PTT	I/O	PTT signal input/output.
	2	HK	I/O	MIC HOOK signal input/output.
	3	RS2	I	Output for remote speaker. (BTL 4W)
	4	ES1	O	Output for external speaker A. (BTL 13W)
	5	SB	O	Power output after power switch. (13.4V/1A)
	6	ES2	O	Output for external speaker A. (BTL 13W)
	7	OS2	O	Output for external speaker B. (BTL 13W)
CN106 To signaling (option)	1	AC2	I	Audio control signal input by the signaling (option).
	2	PTT	I/O	PTT signal input/output for signaling (option).
	3	DEO	O	Detection signal output.
	4	E	-	Earth.
	5	RST	O	RESET signal output for signaling (option).
	6	RLC	O	Controls Horn alert relay. ("L" : Horn alert switch ON)
	7	ALT	I	ALERT signal input for signaling (option).
	8	HN1	I	Horn alert signal input.
	9	HN2	I	Horn alert signal input.
CN107 To signaling (option)	1	MCM	I/O	MIC MUTE signal input/output.
	2	DTM	I	DTMF (option) signal input.
	3	MCO	I	MIC signal input.
	4	8C	O	Common 8V. (8V ± 5%)
	5	DBD	I	DEAD BEAT DISABLE input.
	6	DT3	O	Five-tone data rewrite output.
	7	CK3	O	Five-tone data rewrite output.
CN108 To voice scramble	1	MIC	O	MIC signal output.
	2	MCO	I	MIC signal input.
	3	8C	O	Common 8V. (8V ± 5%)
	4	E	-	Earth.
	5	AC1	O	Audio control signal output. OPT SW ON : "L", OFF : "H"
	6	PTT	I/O	PTT signal input/output.
	7	DEO	O	Detection signal output.
	8	DE2	I	Detection signal input.
	9	0	O	SCRAMBLE code output.
	10	2	O	SCRAMBLE code output.
	11	4	O	SCRAMBLE code output.
	12	8	O	SCRAMBLE code output.
W105 To remote head	1	RS2	O	Output for remote speaker. (BTL 4W)
	2	RS1	O	Output for remote speaker 1. (BTL 4W)
	3	SB	O	Power output after power switch. (13.4V ± 15%)
	4	SPR	I	SPARE reserved input terminal.
	5	PS	I	Power switch control signal input.
	6	CD	O	CLOCK output to the display unit (option).
	7	DD	I/O	DATA signal input/output for display unit (option).
	8	VOL	I	Electronic volume control signal input.
	9	E	-	Earth.

TERMINAL FUNCTIONS

Connector No.	Terminal No.	Terminal Name	I/O	Terminal Function
	10	MIC	I	MIC signal input.
	11	ME	-	MIC earth.
TX-RX UNIT (X57-3750-10) (B/3)				
CN301 To final unit	1	RA	I	Receiver signal input, coaxial connector.
CN302 To VCO/PLL unit	1	REF	O	TCXO 12.8MHz output for COM PLL IC.
	2	CP	O	CLOCK signal output for COM PLL IC.
	3	E	-	Earth.
	4	DP	O	DATA signal output for COM PLL IC.
	5	LS	O	PLL LPF select signal output.
	6	EP	O	PLL ENABLE signal output for COM PLL IC.
	7	STR	O	Standby RX. (RX : "H". TX : "L")
	8	E	-	Earth.
	9	MP	O	MODULATION signal output.
	10	LD	I	LOCK detect input. (LOCK : "H", UNLOCK : "L")
	11	5V	O	5V AVR.
	12	E	-	Earth.
	13	CV	I	PLL LOCK voltage input.
	14	OUT	I	VCO signal input.
	15	8V	O	Common 8V. (8V ± 5%)
CN303 To final unit	1	DO	O	Transmission drive output, coaxial connector. (200mW)
CN304 To final unit	1	DB	I	Transmission drive control voltage input. (APC)
	2	E	-	Earth.
	3	8R	O	8V output during reception.
	4	8T	O	8V output during transmission.
CN305 To control unit	1	DP	I	DATA input for PLL.
	2	EP	I	ENABLE input for PLL.
	3	CP	I	CLOCK input for PLL.
	4	LD	O	LOCK detect output for PLL. (LOCK : "H", UNLOCK : "L")
	5	TO	I	TONE signal input.
	6	ES	I	ENABLE input for shift register.
	7	MO	I	Modulation signal input.
	8	8C	I	Common 8V. (8V ± 5%)
	9	E	-	earth.
	10	8C	I	Common 8V. (8V ± 5%)
	11	DET	O	Detection signal output.
	12	NC	-	Not use.
	13	NC	-	Not use.
AF UNIT (X57-3750-10) (C/3)				
CN501 To control unit	1	OS1	O	Output for external speaker B. (BTL 13W)
	2	OS1	O	Output for external speaker B. (BTL 13W)
	3	ES1	O	Output for external speaker A. (BTL 13W)
	4	ES1	O	Output for external speaker A. (BTL 13W)
	5	CSP	O	Output for common speaker. (BTL 13W)
	6	CSP	O	Output for common speaker. (BTL 13W)
	7	RS1	O	Output for remote speaker. (BTL 4W)
	8	E	-	Earth.
	9	E	-	Earth.
	10	SSC	I	Controls SPEAKER select relay.
	11	AFO	I	Audio input.
	12	PSC	I	Controls power switch relay. (Power SW ON : "L", OFF : "H")
	13	PSB	O	Power output. (unswitched)
	14	SB	O	Power output after power switch. (13.4V ± 15%)

Connector No.	Terminal No.	Terminal Name	I/O	Terminal Function
	15	SB	O	Power output after power switch. (13.4V ± 15%)
	16	SB	O	Power output after power switch. (13.4V ± 15%)
	17	8C	O	Common 8V. (8V ± 5%)
CN502 To final unit	1	E	-	Earth.
	2	B	I	Power supply input. (13.4V ± 15%)
	3	B	I	Power supply input. (13.4V ± 15%)
DISPLAY UNIT (X54-31XX-20) (A/2) 3100 : KCH-3, 3110 : KCH-4 (OPTION)				
CN1 To head ACC connector	1	IRS	I	Internal speaker input. (RS2 ↔ IRS)
	2	RS2	O	Output for remote speaker. (BTL 4W)
	3	RS1	O	Output for external speaker. (RS1 ↔ RS2)
	4	AUX	O	AUX signal output. (space)
	5	E	-	Earth.
	6	SPR	I	SPARE reserved input terminal.
CN2 To control unit	1	ME	-	MIC earth.
	2	MIC	O	MIC signal output.
	3	E	-	Earth.
	4	VOL	O	Electronic volume control signal output.
	5	DD	I/O	DATA signal input/output.
	6	CD	I	CLOCK output.
	7	PS	O	Power switch control signal output.
	8	SPR	O	SPARE reserved output terminal.
	9	SB	I	Power output after power switch. (13.4V)
	10	RS1	I	Input for remote speaker. (BTL 4W)
	11	RS2	I	Input for remote speaker. (BTL 4W)
CN3 To encoder	1	EN1	I	Encoder pulse input.
	2	E	-	Earth.
	3	EN2	I	Encoder pulse input.
CN4 To speaker	1	IRS	O	Internal speaker input.
	2	RS1	O	Internal speaker input.

TK-730H(B) PC BOARD VIEWS

DISPLAY UNIT (X54-3100-20) : KCH-3 Component side view

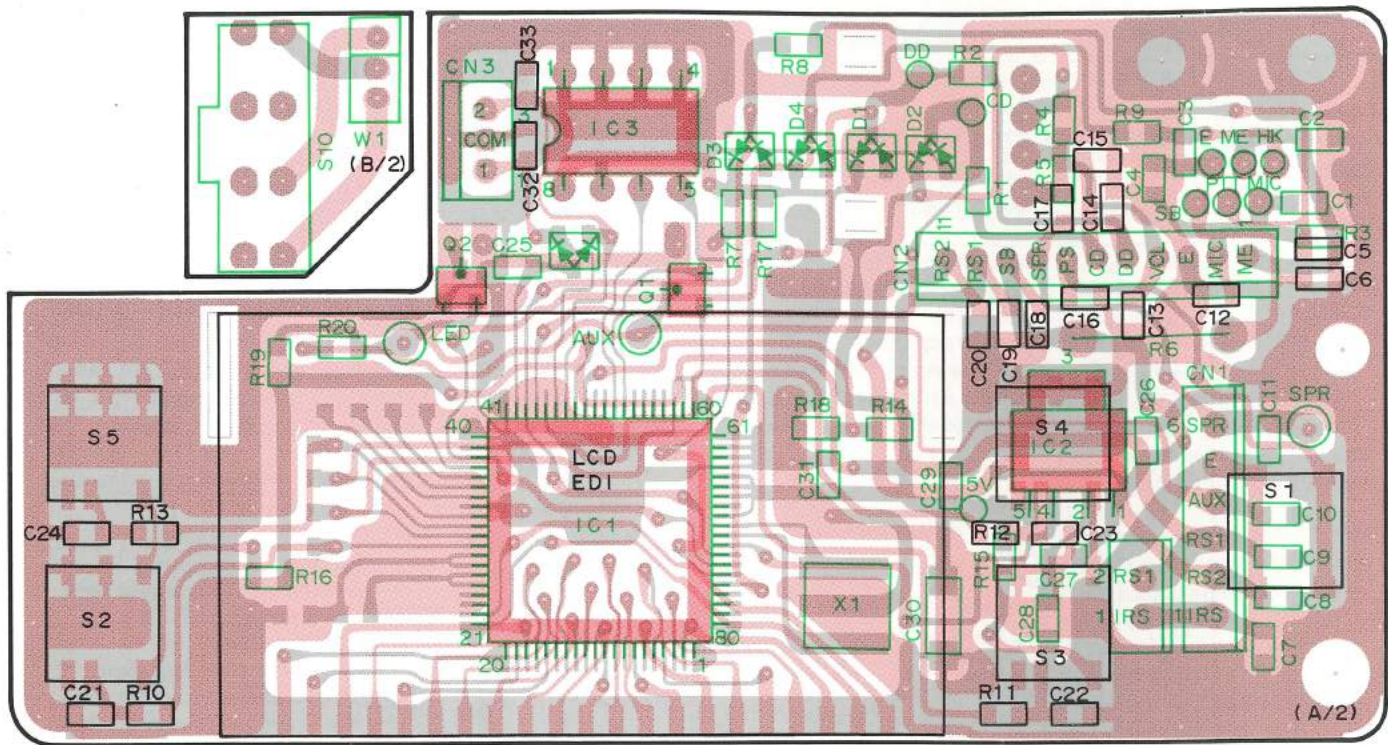

DISPLAY UNIT (X54-3100-20) : KCH-3 Foil side view

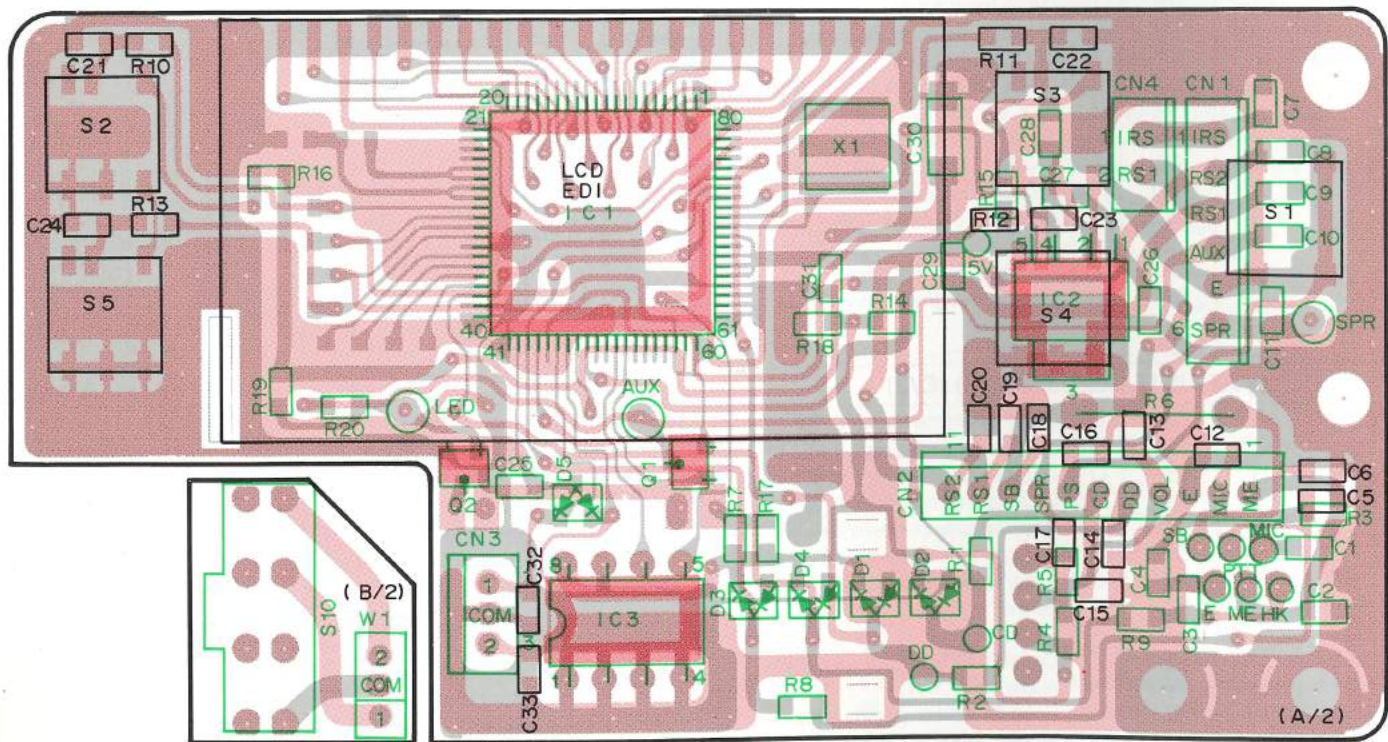

L78LR05B-FA

75328GC5563B9

DTC114EK
DTD114EK

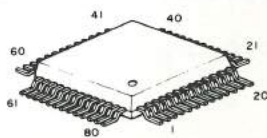
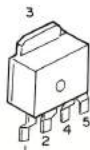

CIRCUIT DIAGRAM TK-730H(B)

KCH-3 (X54-3100-20) (A/2)

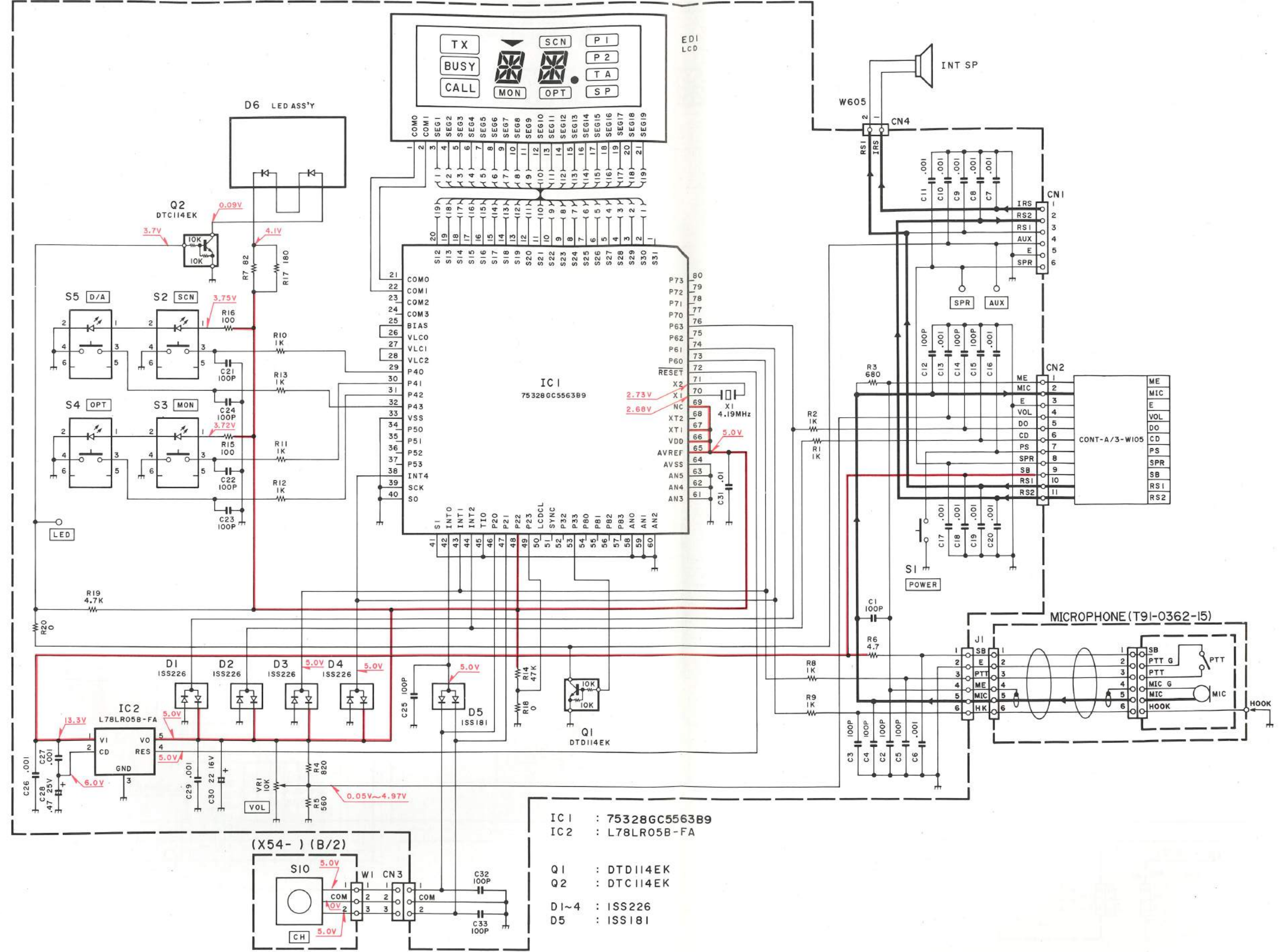

- IC1 : 75328GC5563B9
 IC2 : L78LR05B-FA
- Q1 : DTD114EK
 Q2 : DTC114EK
- D1~4 : ISS226
 D5 : ISS181

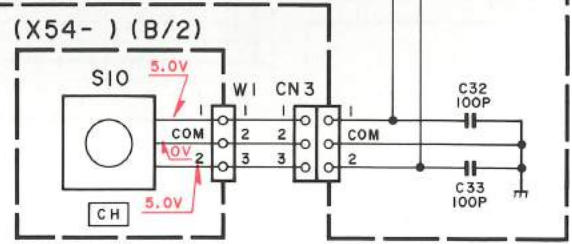

TK-730H(B) CIRCUIT DIAGRAM

KCH-4 (X54-3110-20)(A/2)

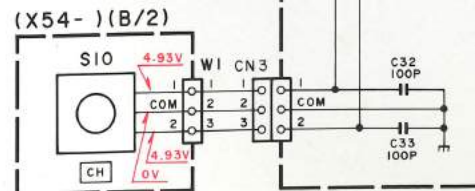
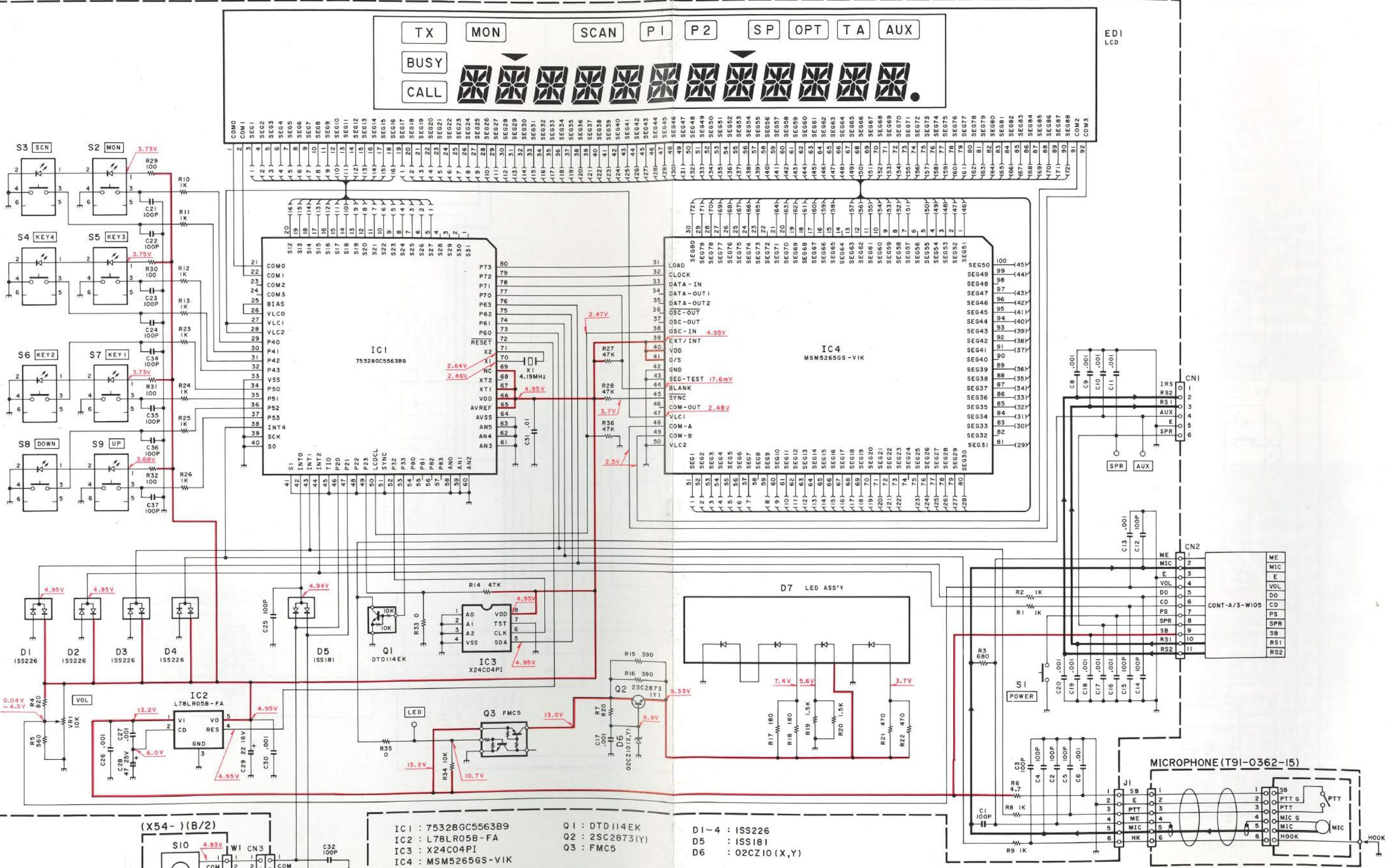

- IC1 : 75328GC5563B9
- IC2 : L78LR05B-FA
- IC3 : X24C04PI
- IC4 : MSM5265GS-VIK
- Q1 : DTD114EK
- Q2 : 2SC2873(Y)
- Q3 : FMC5
- D1-4 : ISS226
- D5 : ISS181
- D6 : 02CZ10(X,Y)

L78LR05B-FA

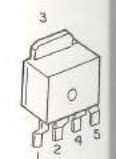

X24C04PI



2SC2873



MSM5265GS-V



DTD114EK

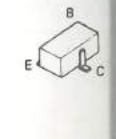

FMC5

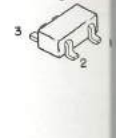

75328GC5563B9



PC BOARD VIEWS TK-730H(B)

DISPLAY UNIT (X54-3110-20) : KCH-4
Component side view

DISPLAY UNIT (X54-3110-20) : KCH-4
Foil side view

L78LR05B-FA

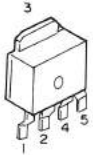

X24C04PI

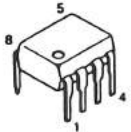

2SC2873



MSM5265GS-V1K

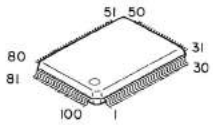

DTD114EK



FMC5

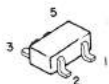

75328GC5563B9

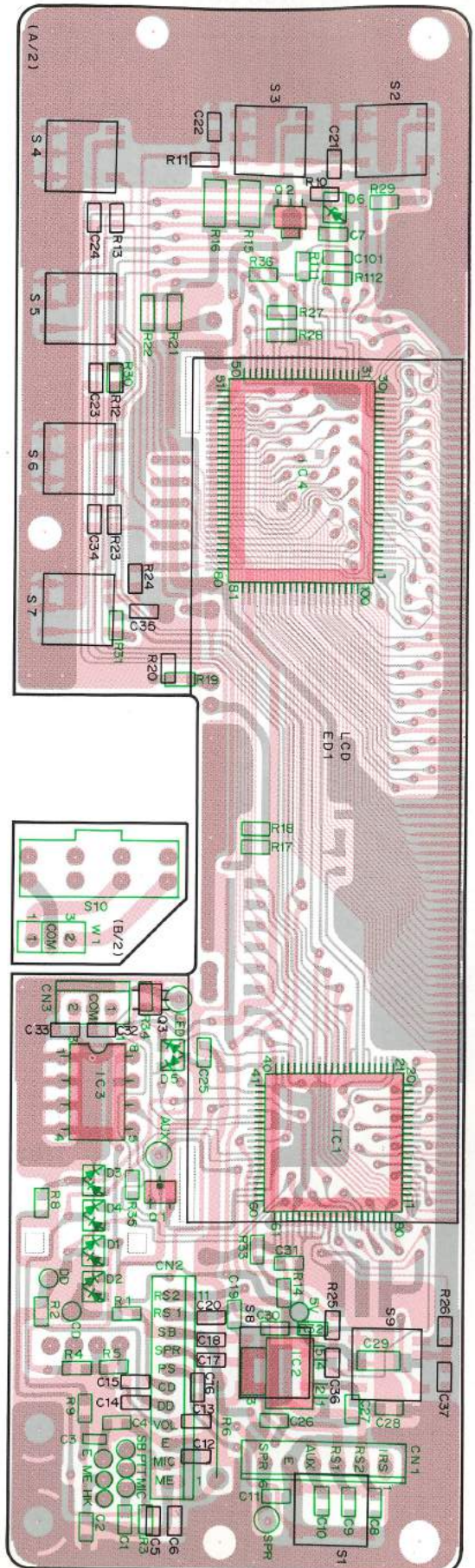
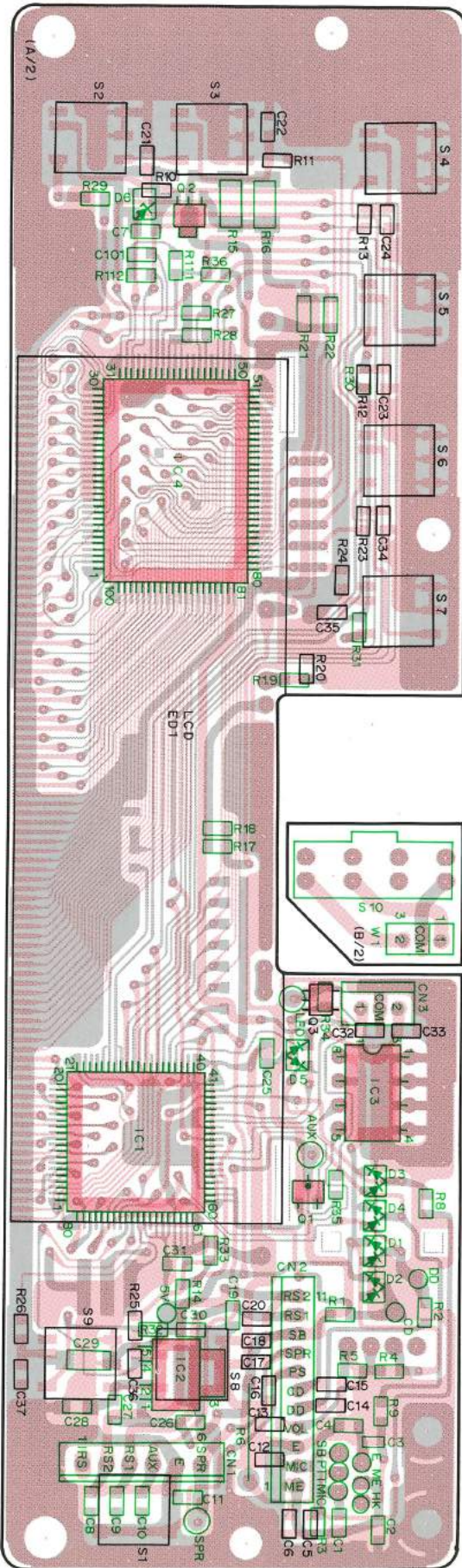
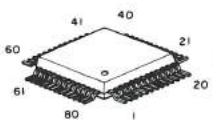

TK-730H(B) PC BOARD VIEWS

VCO/PLL UNIT (X58-3810-10) Component side view

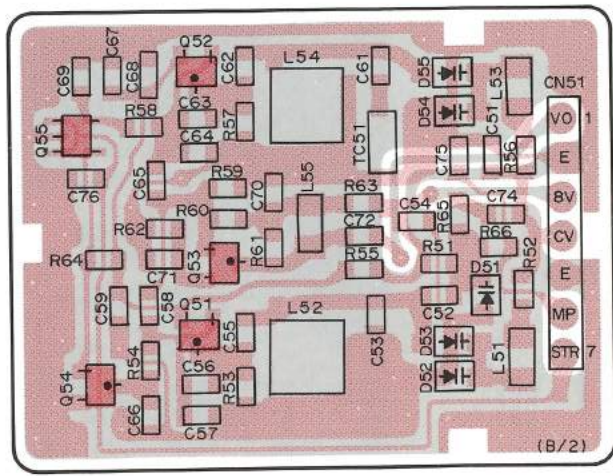
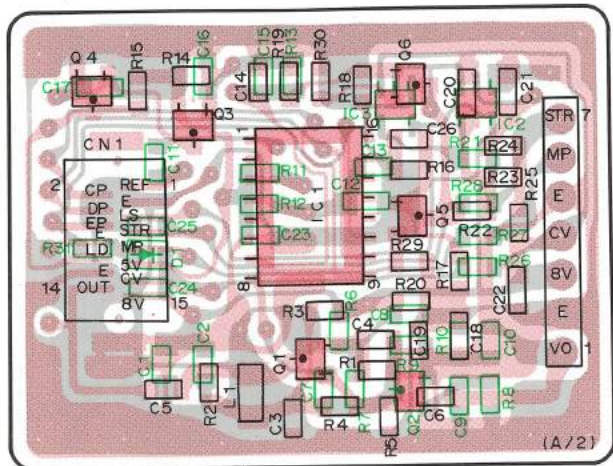

VCO/PLL UNIT (X58-3810-10) Foil side view

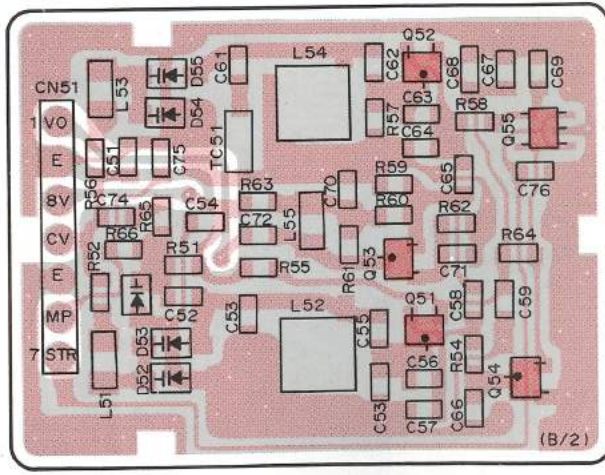
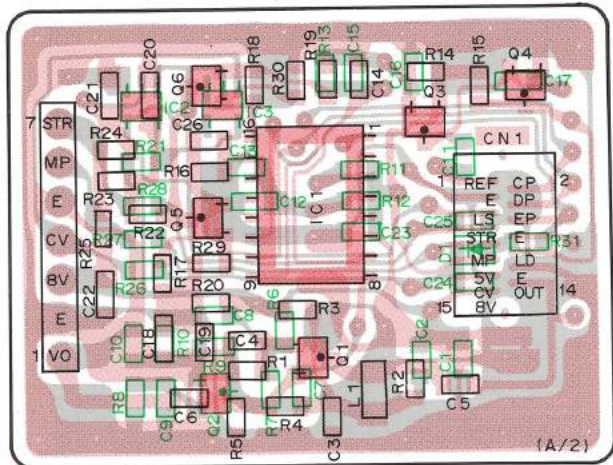

MB1504PF

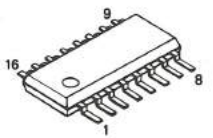

2SD1682



DTC114EK
DTC143EK
2SA1162
2SA1312
2SC2712
2SC2714
2SC3324



2SD1406



FMC2
FMG2
FMW1

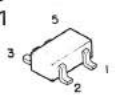

2SK508NV



2SC2782

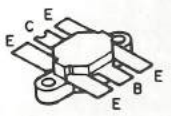

FINAL UNIT (X45-3390-10) Component side view

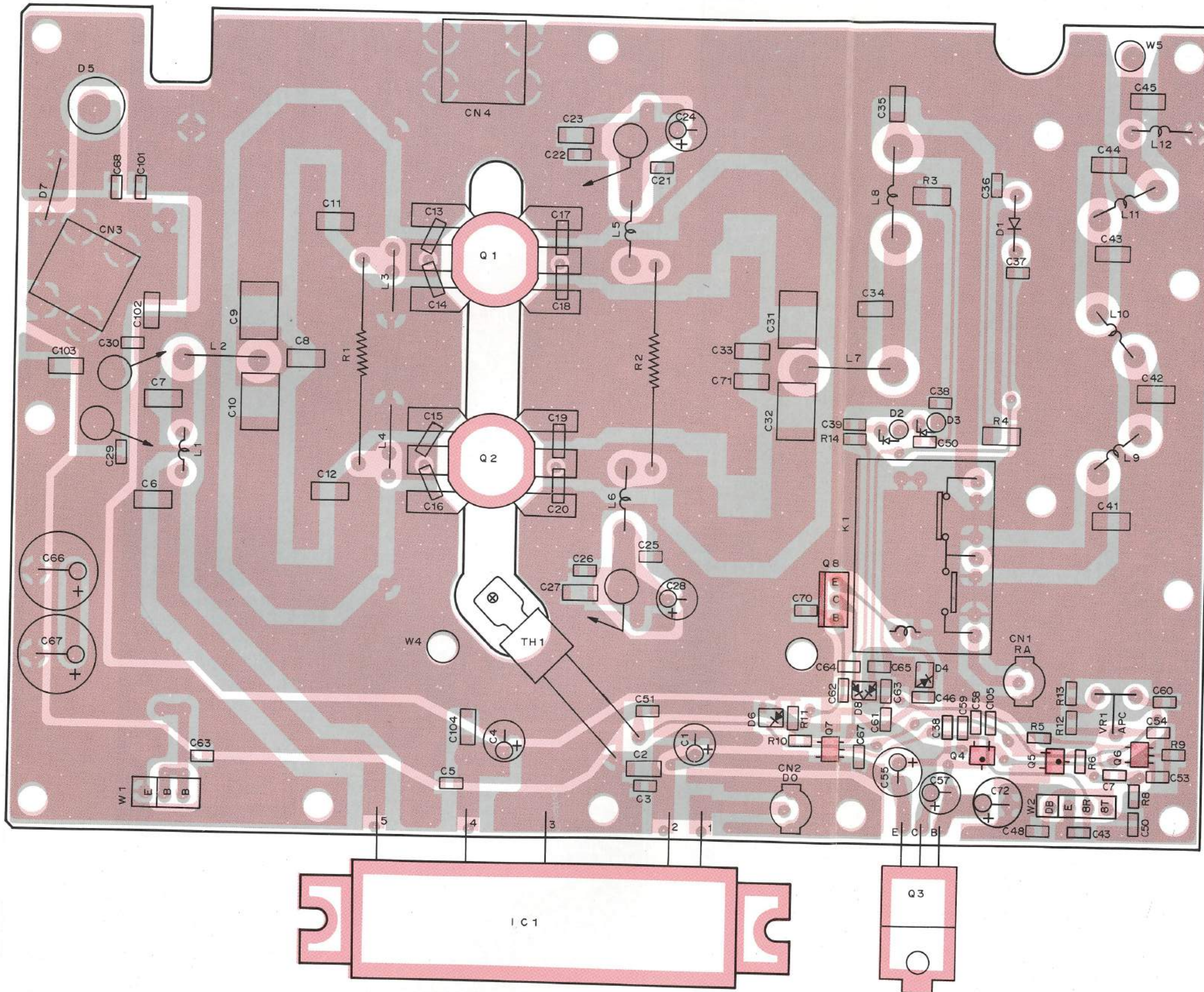

FINAL UNIT (X45-3390-10) Foil side view

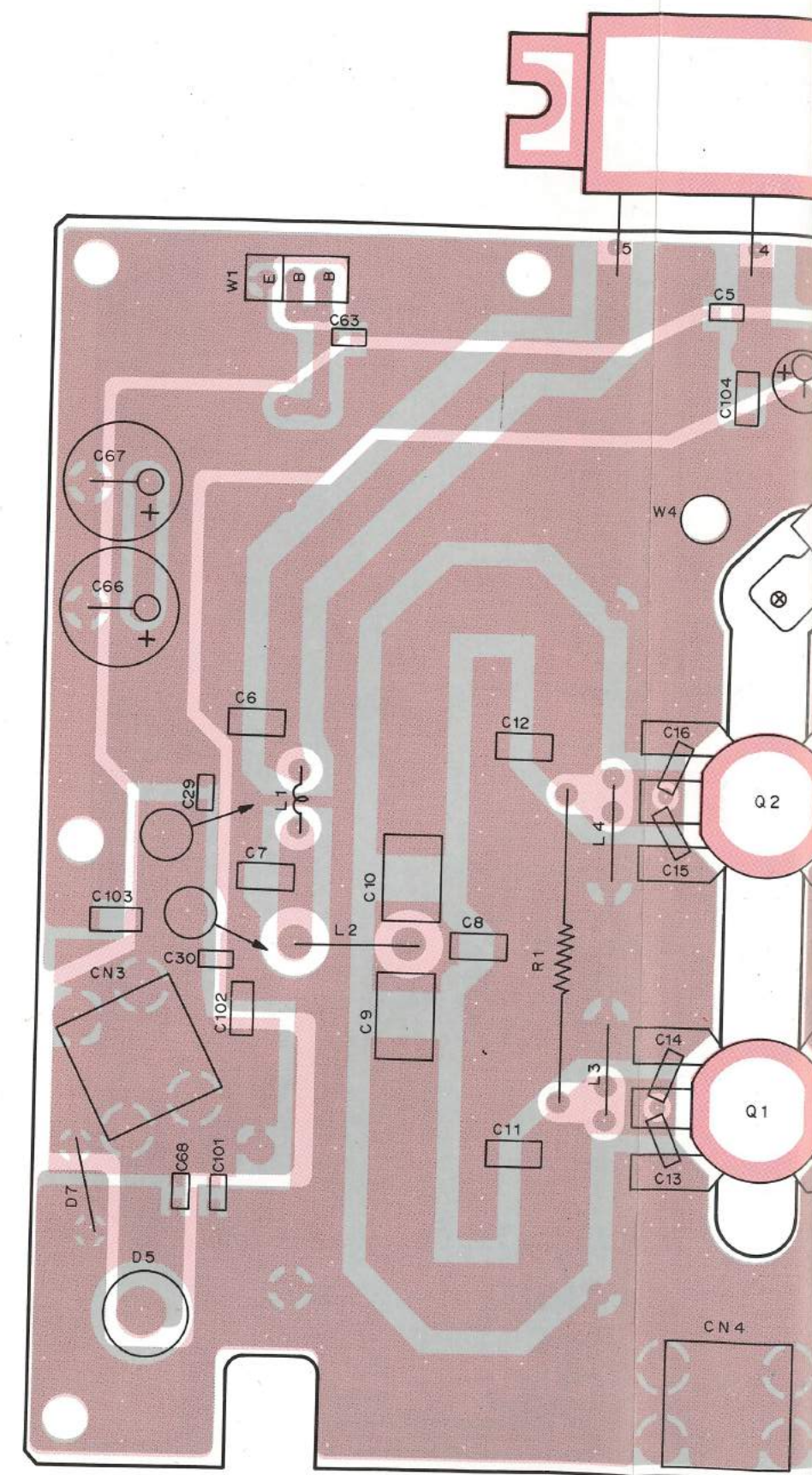

FINAL UNIT (X45-3390-10) Foil side view

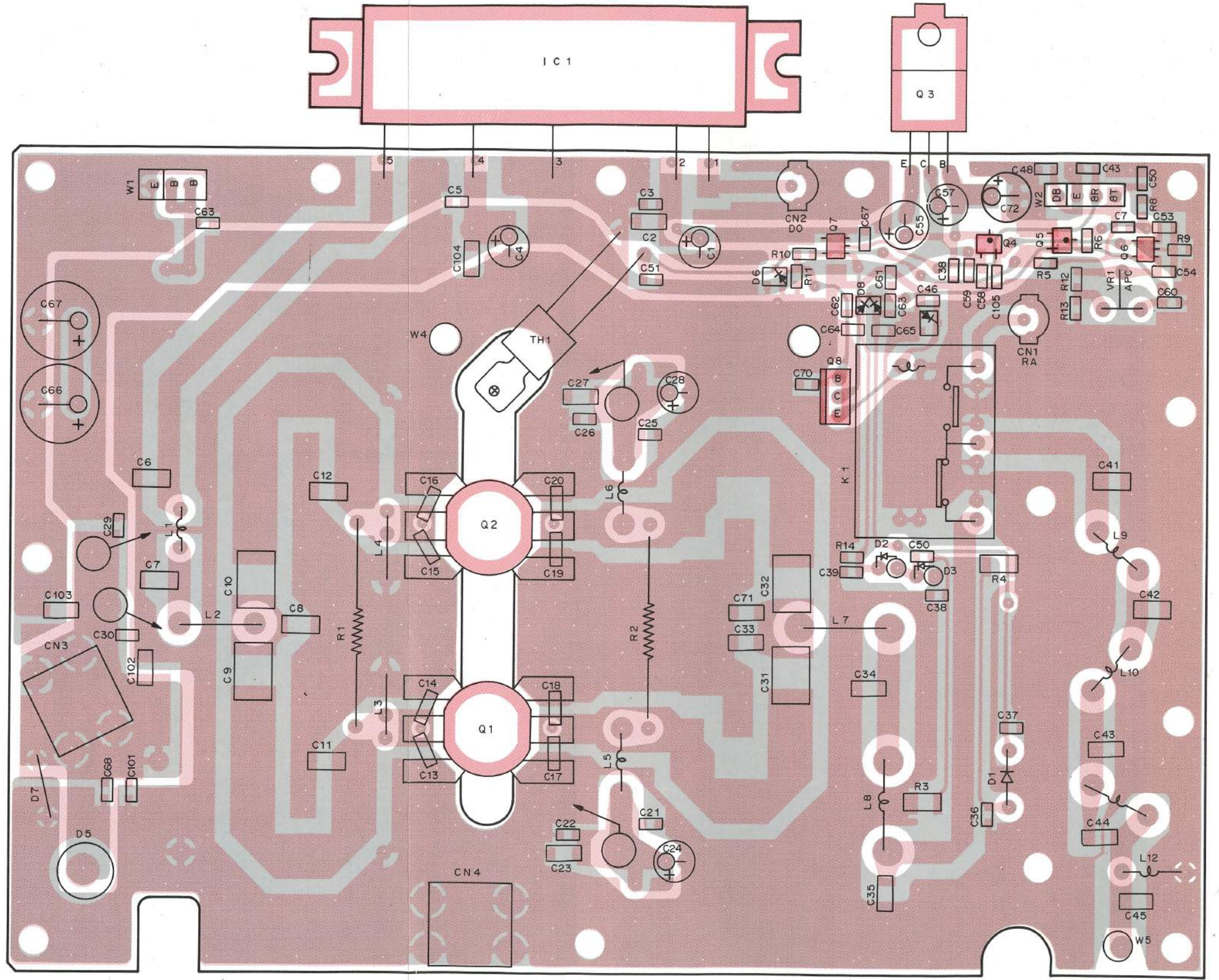
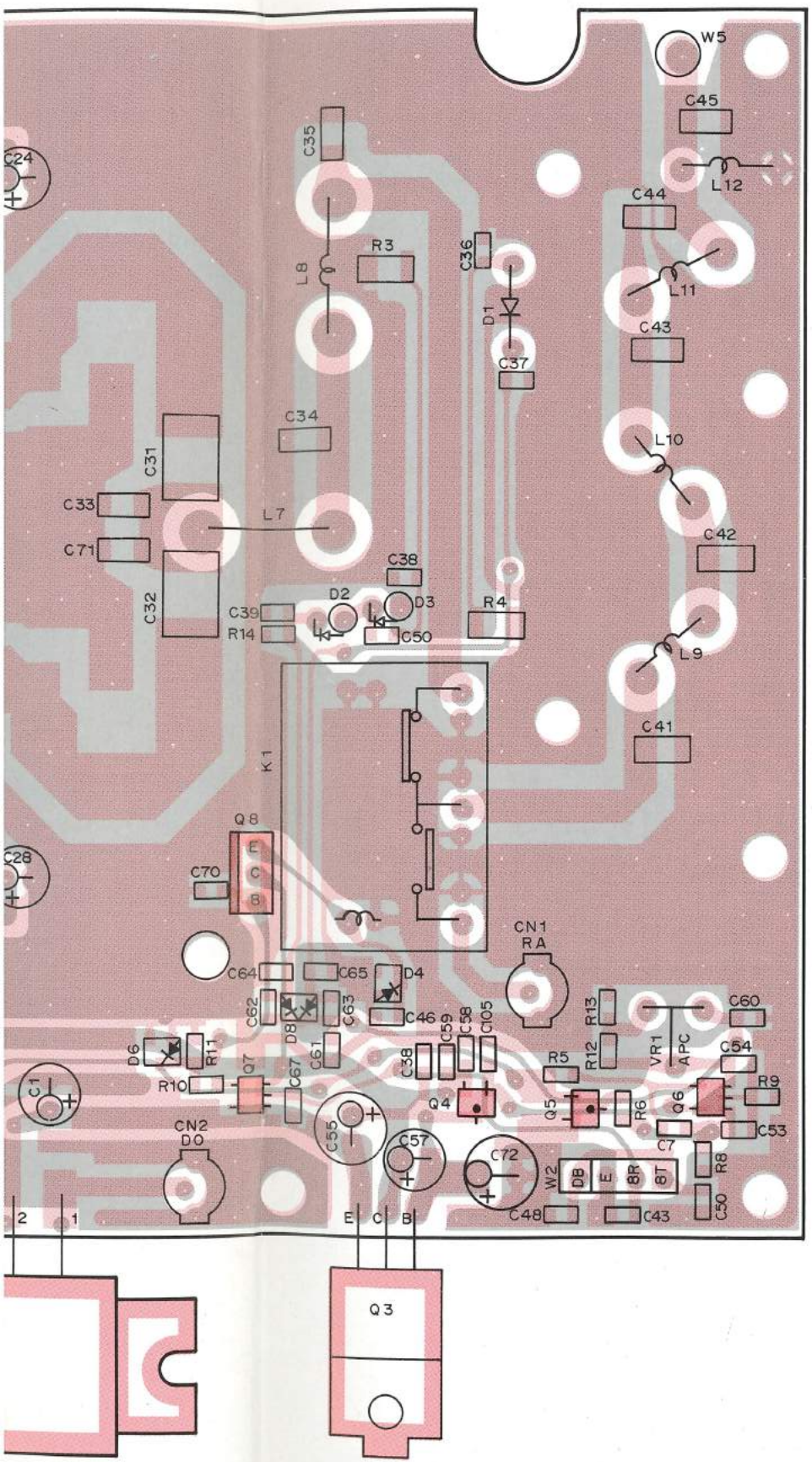

TK-730H(B) PC BOARD VIEWS

TX-RX UNIT (X57-3750-10) Component side view

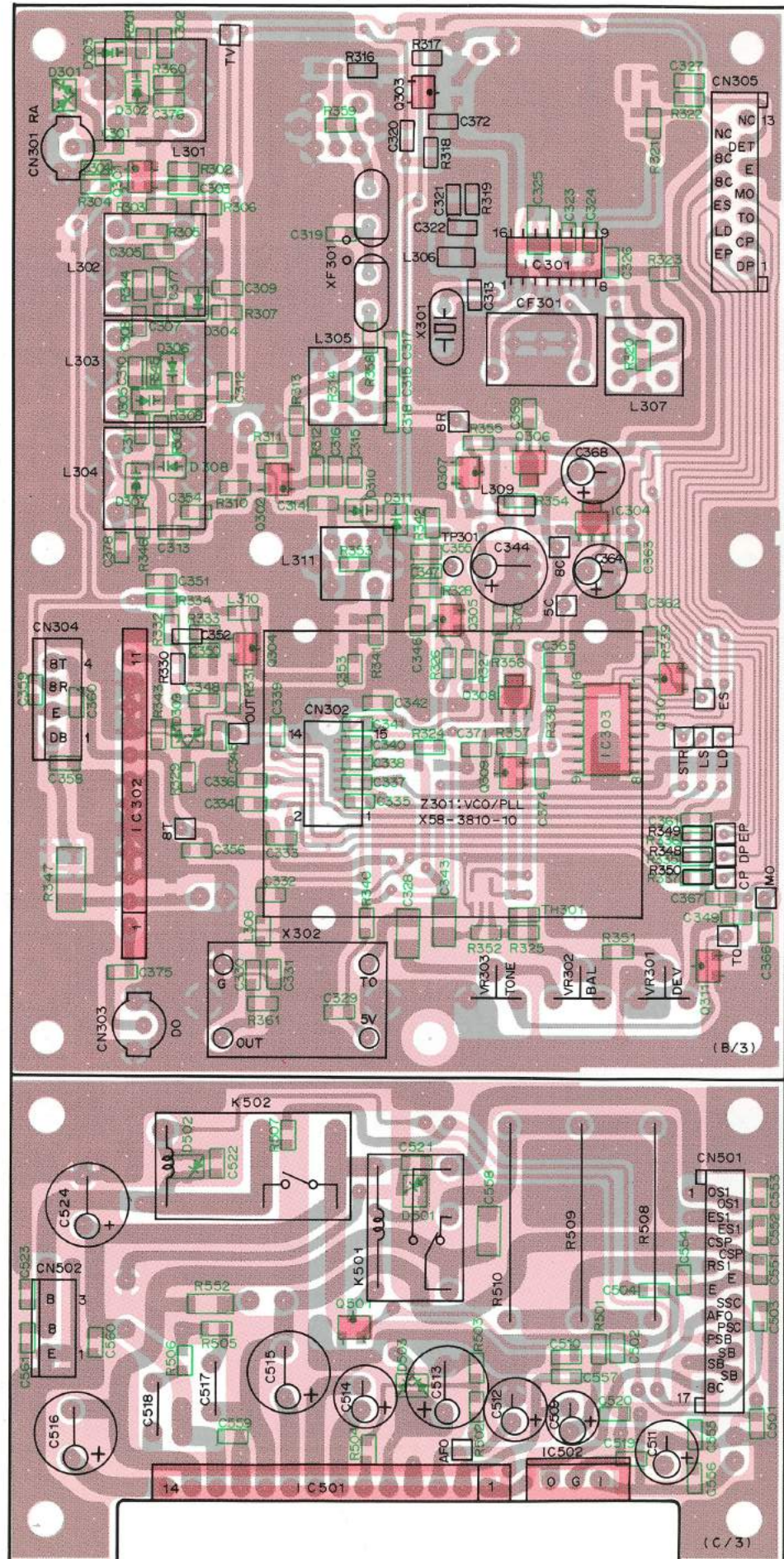

TX-RX UNIT (X57-3750-10) Foil side view

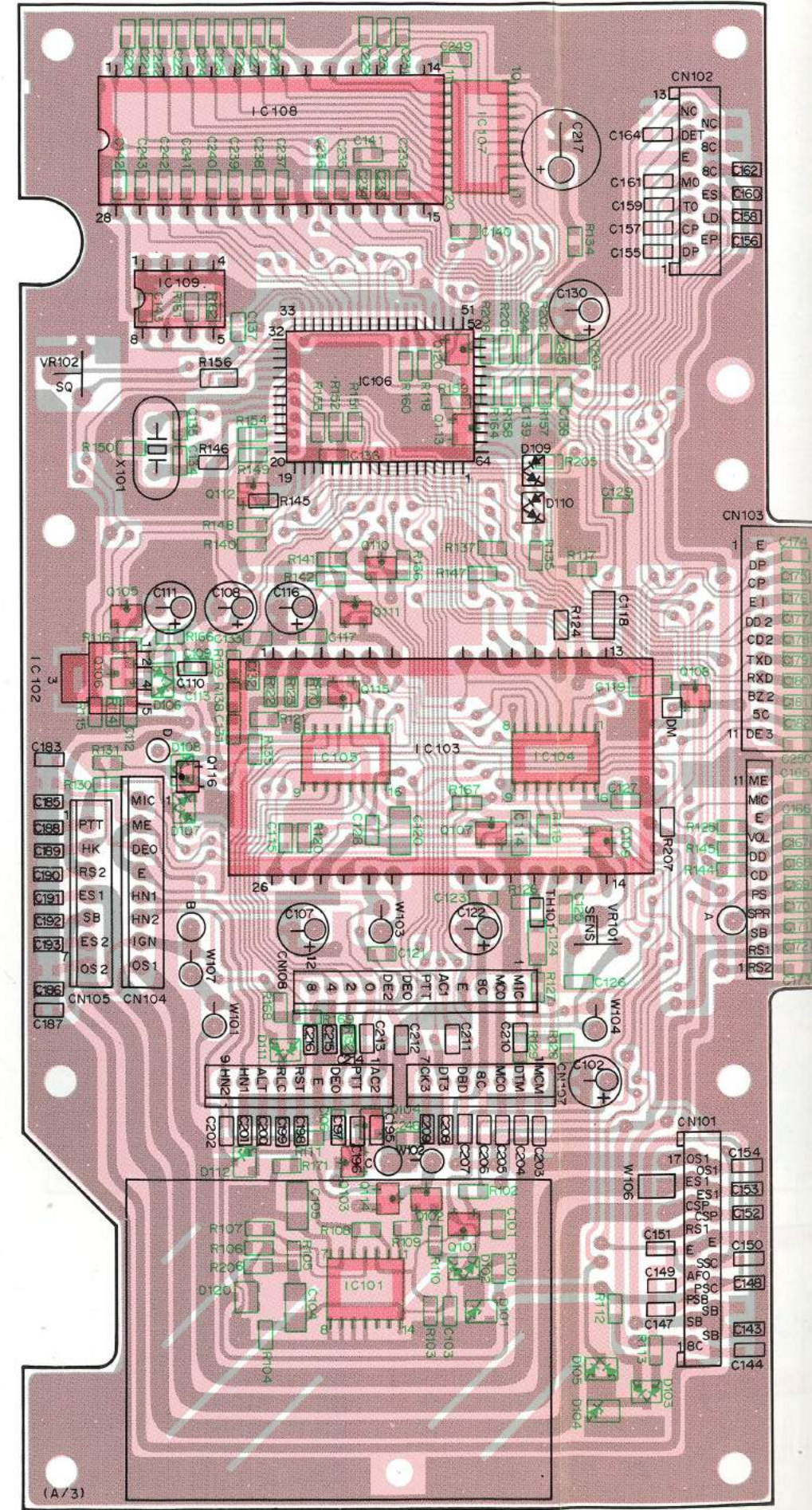
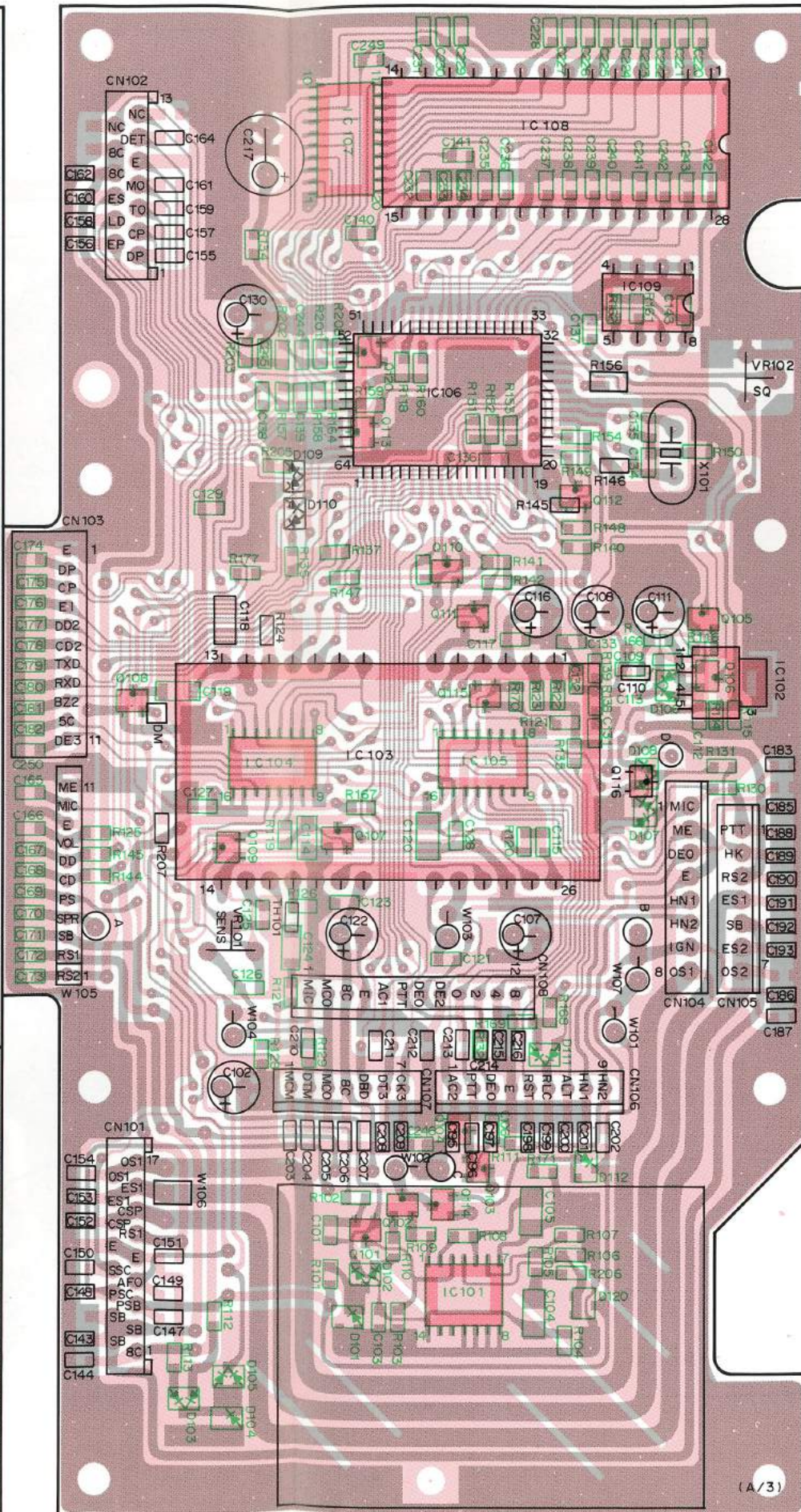

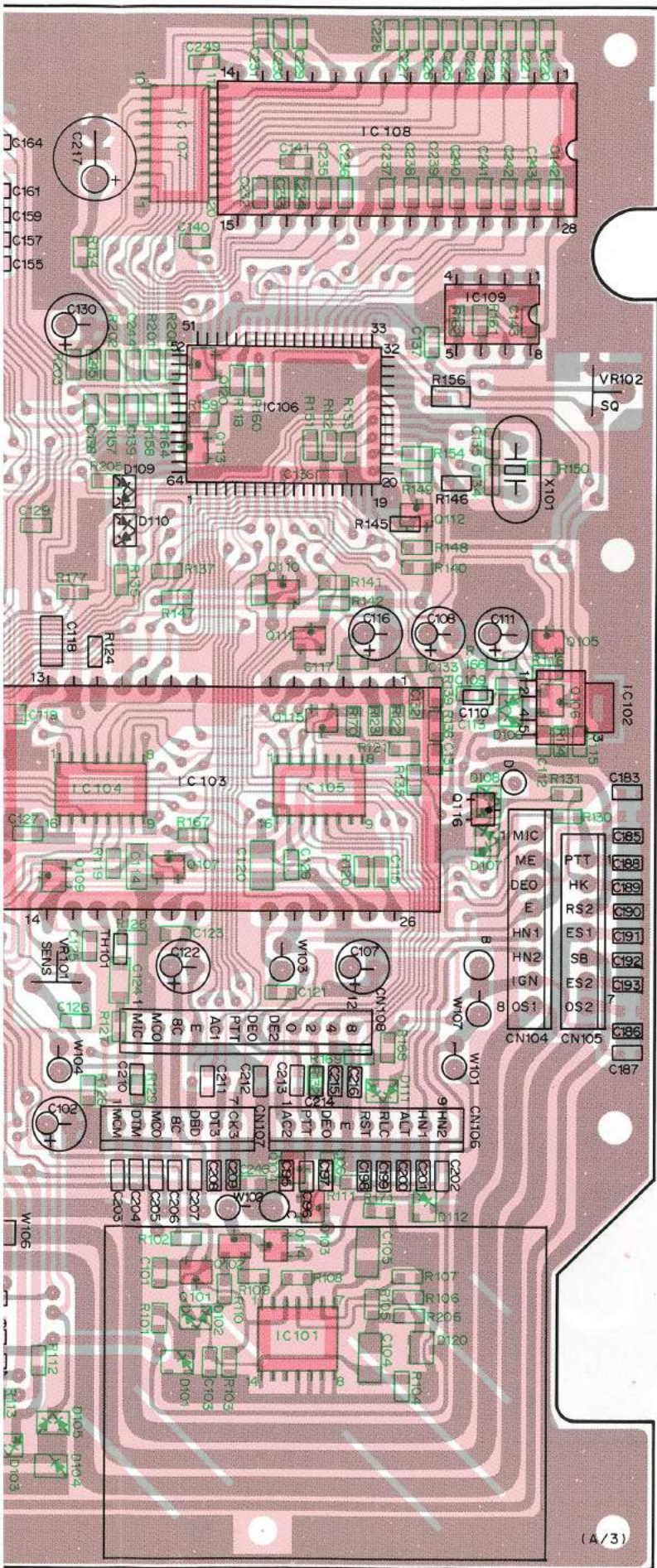

TX-RX UNIT (X57-3750-10) Foil side view

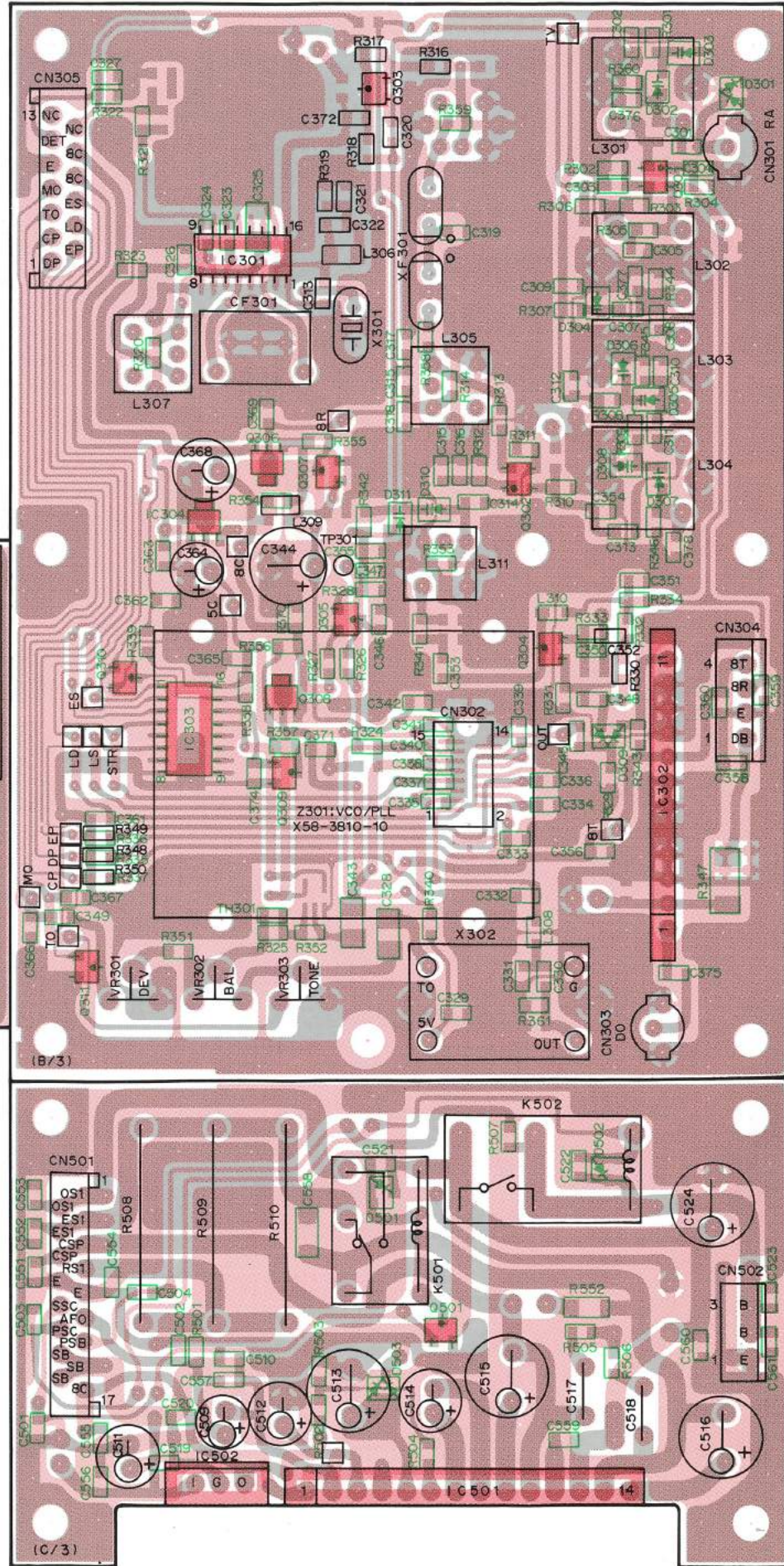
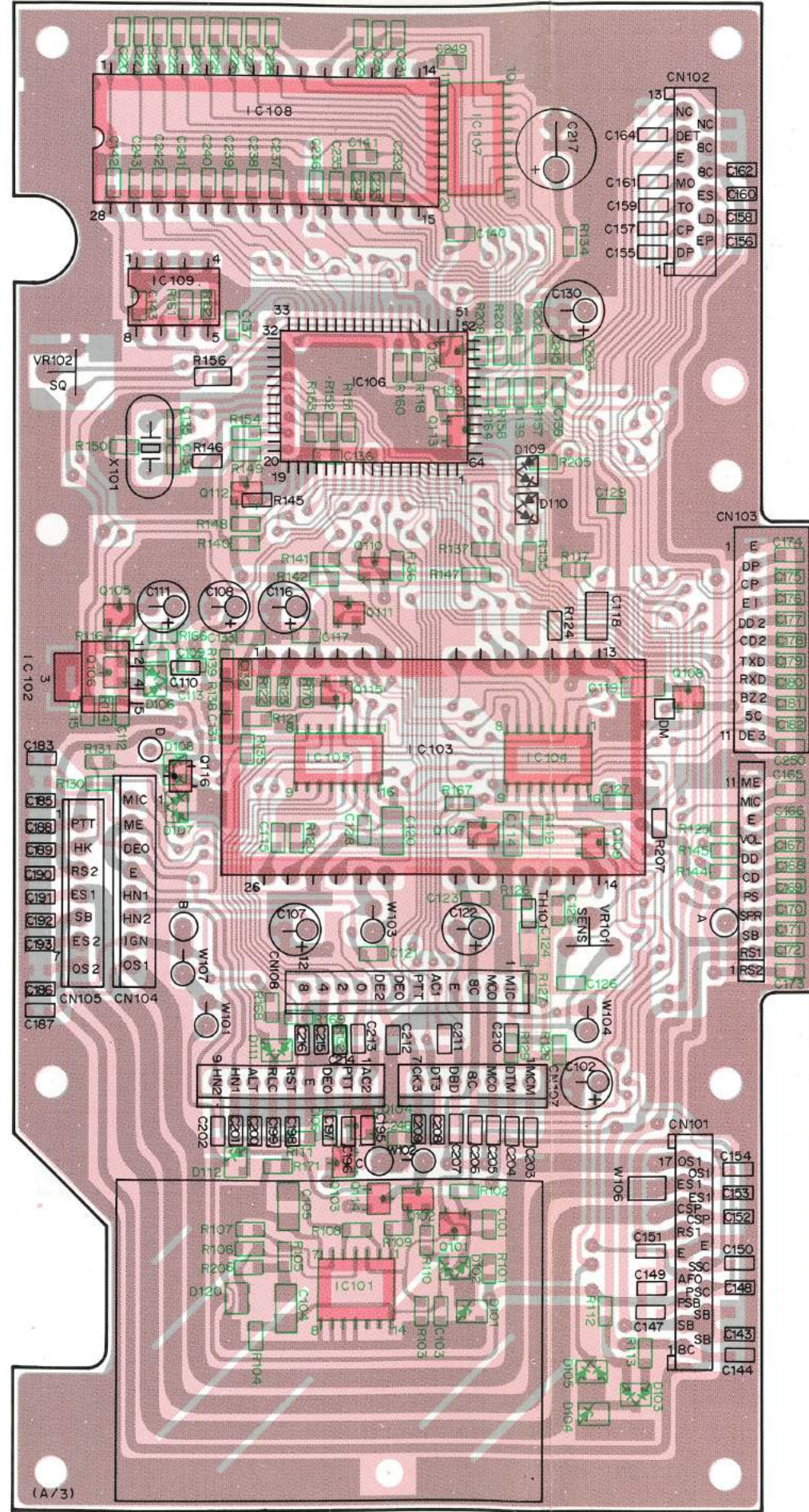

- IC 301 : MC3371D
- IC 302 : KCB05
- IC 303 : BU4094BF
- IC 304 : NJM78L05UA or RC78L05UA

- Q301 : 3SK184 (S)
- Q302 : 3SK140 (GR)
- Q303, 304 : 2SC2714 (Y)
- Q305 : 2SK208 (Y)
- Q306, 308 : 2SB1119S
- Q307, 309 ~ 311 : DTC114EK

- D301 : ISS226
- D302, 304, 306 ~ 308, 310 : ISVI64
- D303, 305, 311 : ISVI66
- D309 : ISS184

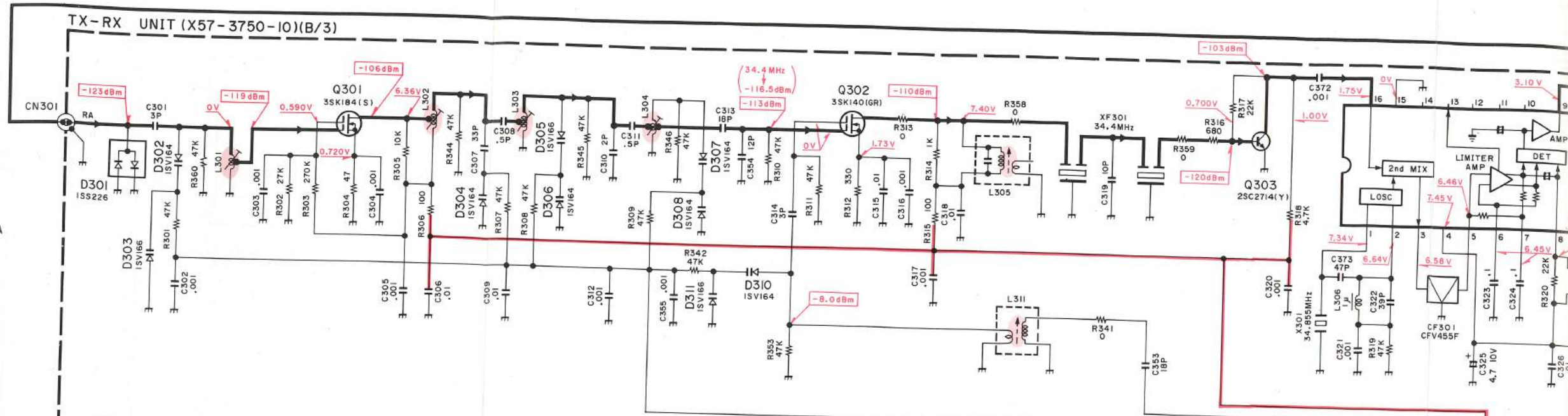

Z301 VCO/PLL (X58-3810-10)

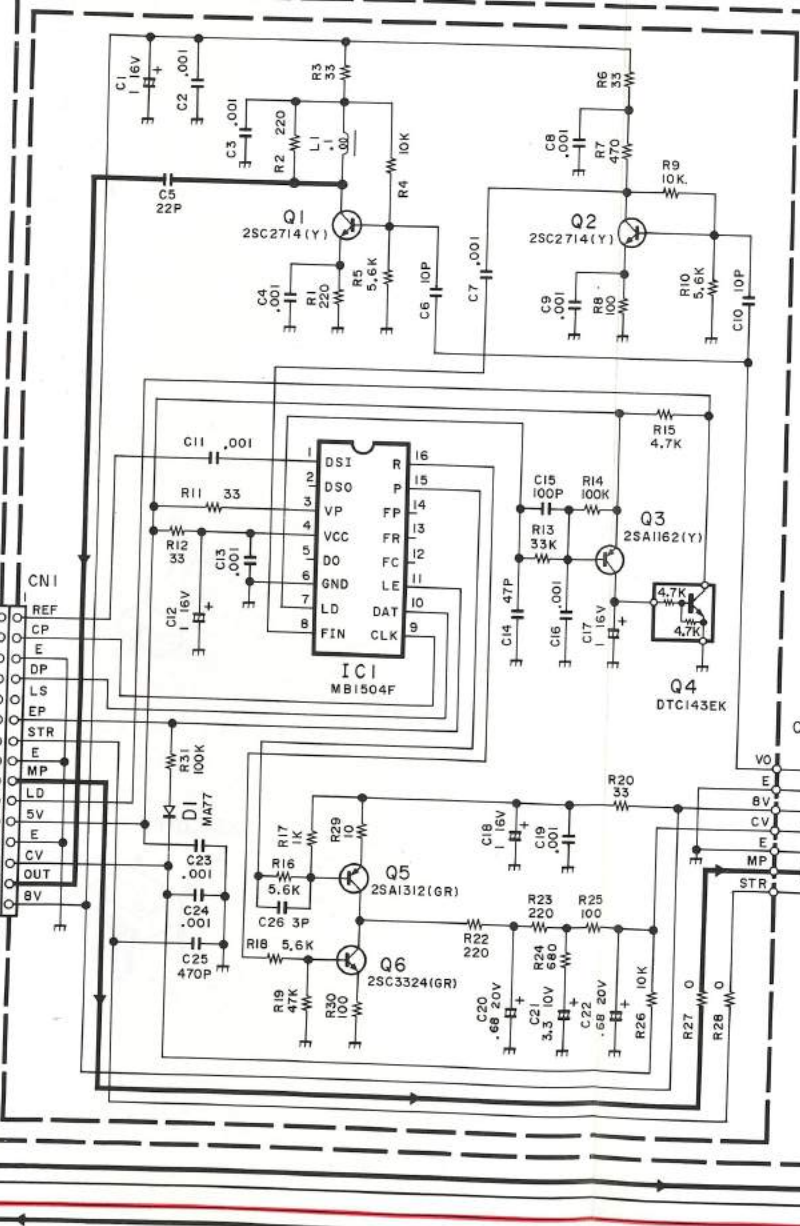

- IC 1 : MBI504F
- Q1, 2, 53 : 2SC2714 (Y)
- Q3 : 2SA1162 (Y)
- Q4 : DTC143EK
- Q5 : 2SA1312 (GR)
- Q6 : 2SC3324 (GR)
- Q51, 52 : 2SK508NV (K52)
- Q54 : DTC114EK
- Q55 : FMG2
- D1 : MA77
- D51 : ISVI64
- D52~55 : IT33C

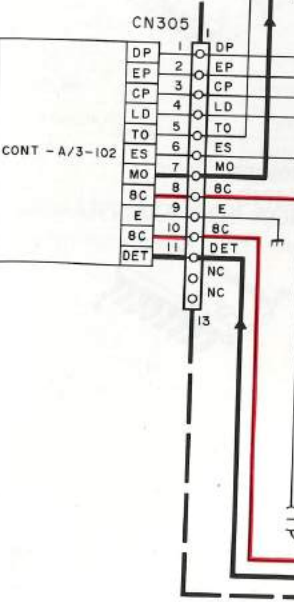
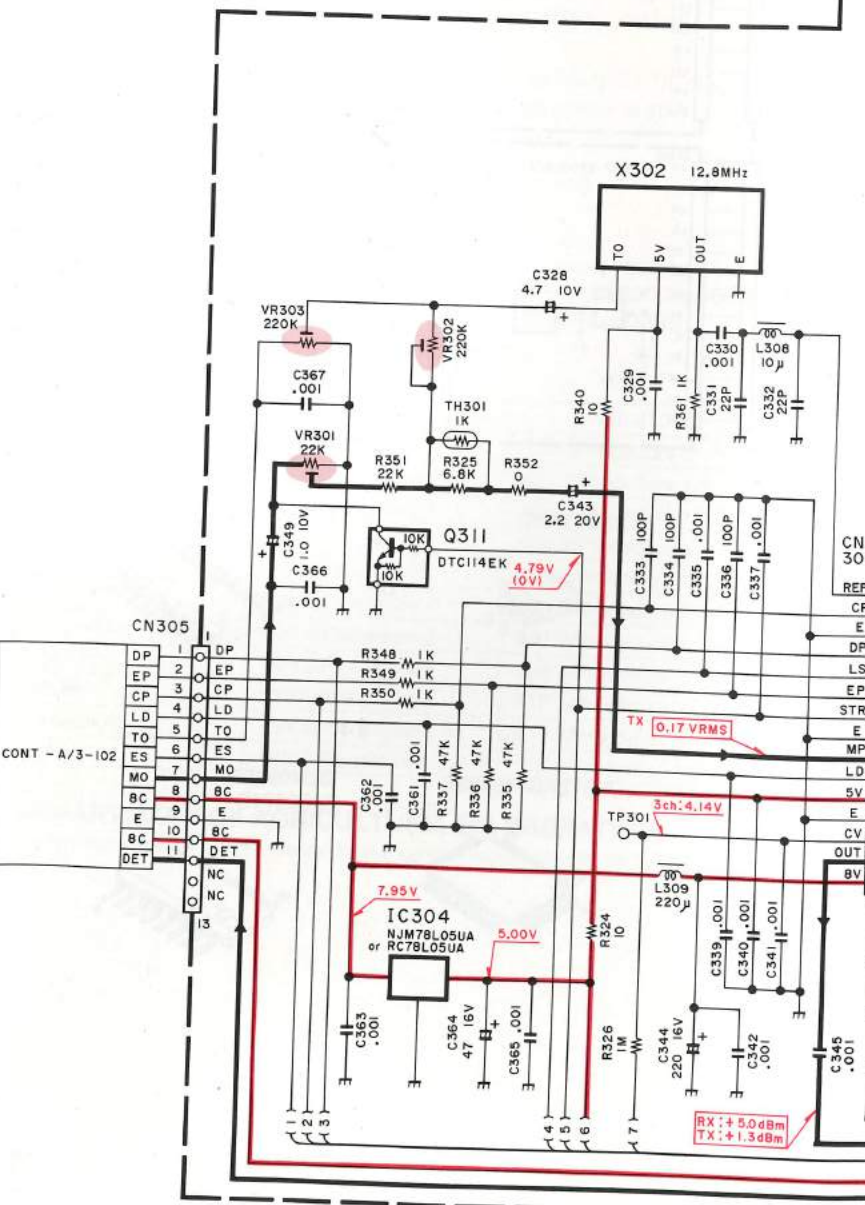
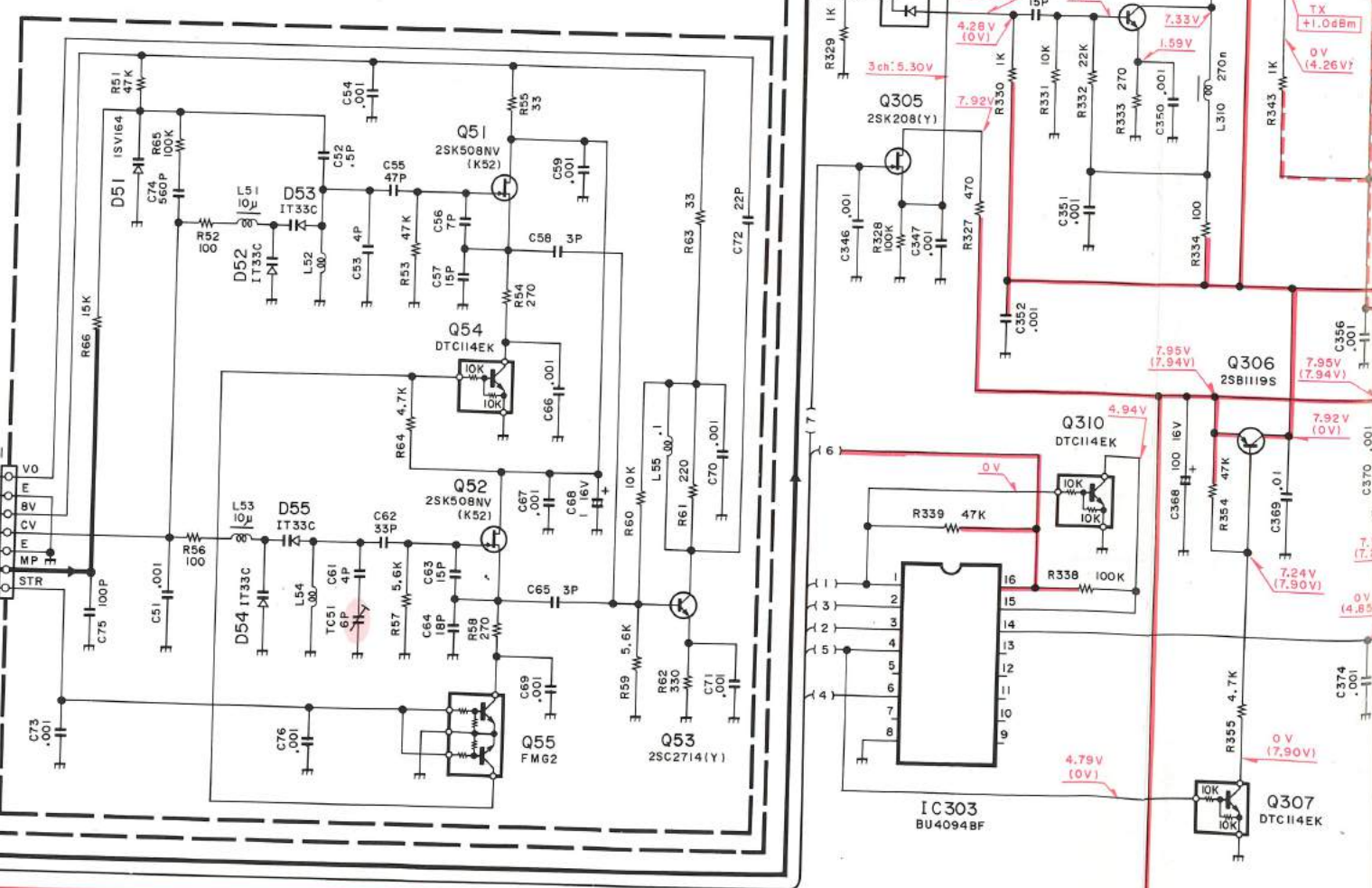

CIRCUIT DIAGRAM TK-730H(B)

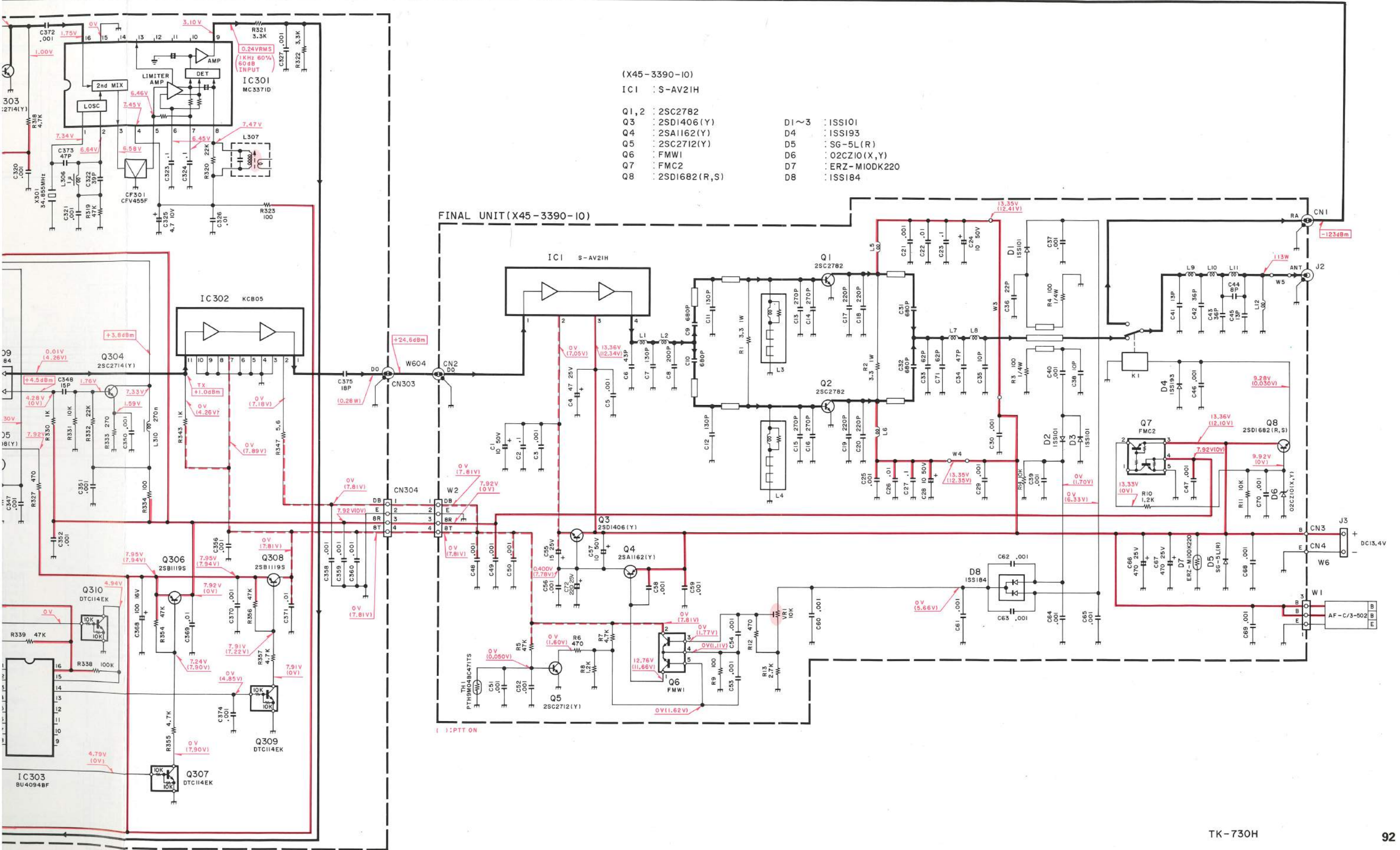

(X45-3390-10)
IC1 : S-AV21H

- Q1, 2 : 2SC2782
- Q3 : 2SD1406(Y)
- Q4 : 2SA1162(Y)
- Q5 : 2SC2712(Y)
- Q6 : FMW1
- Q7 : FMC2
- Q8 : 2SD1682(R,S)

- D1~3 : ISS101
- D4 : ISS193
- D5 : SG-5L(R)
- D6 : O2CZ10(X,Y)
- D7 : ERZ-MI0DK220
- D8 : ISS184

FINAL UNIT (X45-3390-10)

TK-730H(B) SCHEMATIC DIAGRAM

CONTROL UNIT (X57-3750-10)(A/3)

- IC101 TC4013BF
- IC102 L78LR05B-FA
- IC103 KCE04
- IC104,105 BU4094BF
- IC106 78312AGF3343BE
- IC107 TC74HC573AF
- IC108 27C256BQ-JBY2
- IC109 X24C04PI

- Q101,102 DTA114EK
- Q103,104,116 DTD114EK
- Q105,108~112,114,115 DTC114EK
- Q106 2SC2712(Y)
- Q107 2SD1757(K)

- D101 02CZ18(X,Y)
- D102 ISS181
- D103,105,106,111 ISS184
- D104 02CZ5.6(X,Y)
- D107~110 ISS226
- D112 02CZ15(X,Y)

KCH-3 (X54-3100-20)(A/2)
KCH-4 (X54-3110-20)(A/2)

(X54-)(B/2)

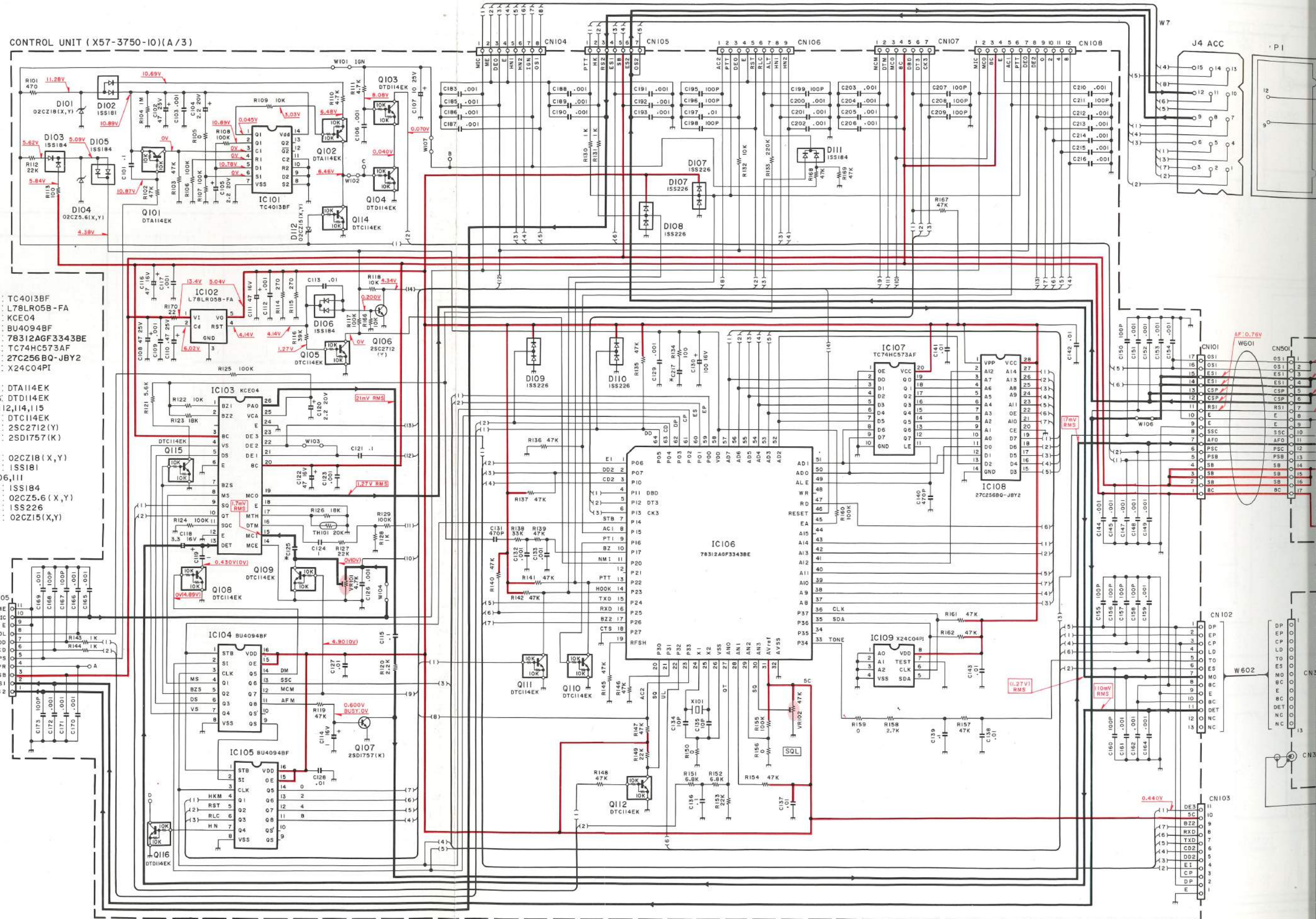

TK-730H(B) POWER SUPPLY BLOCK DIAGRAM

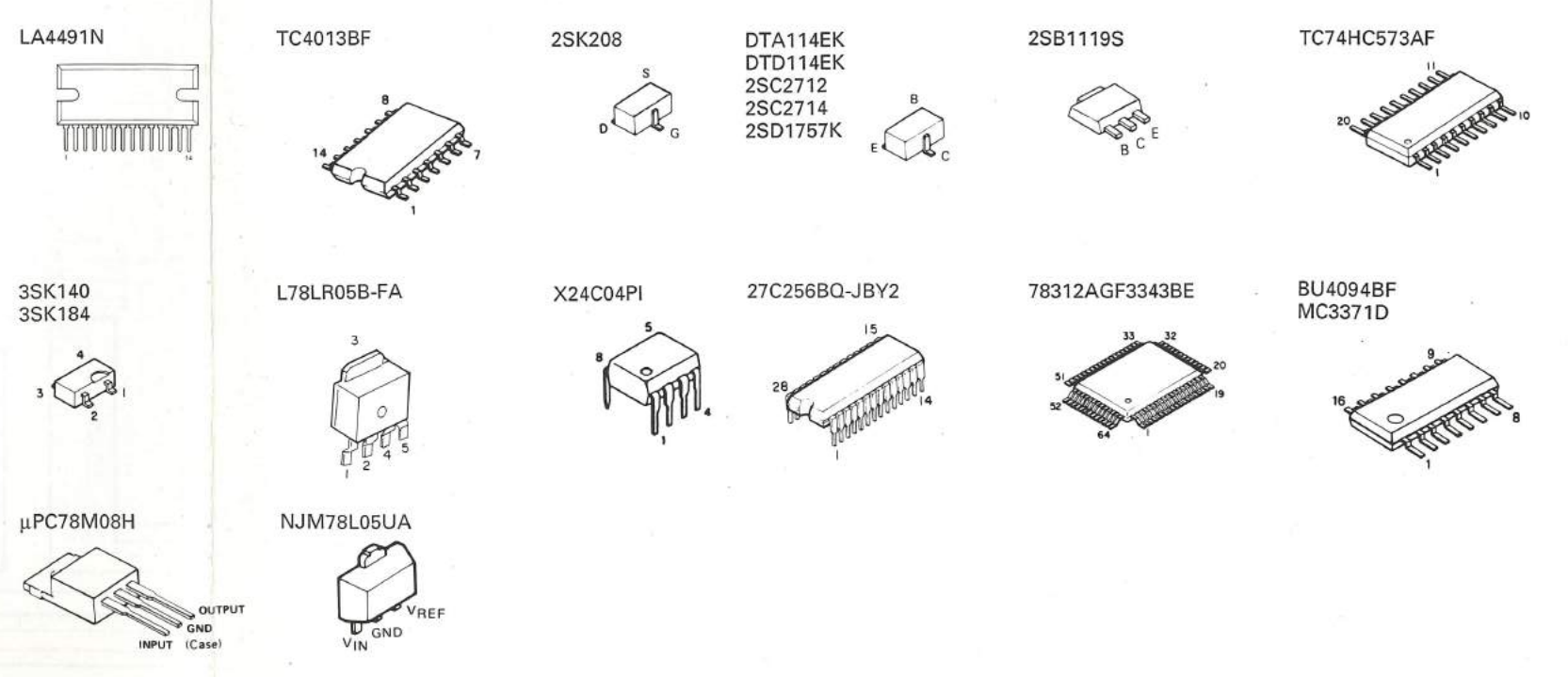
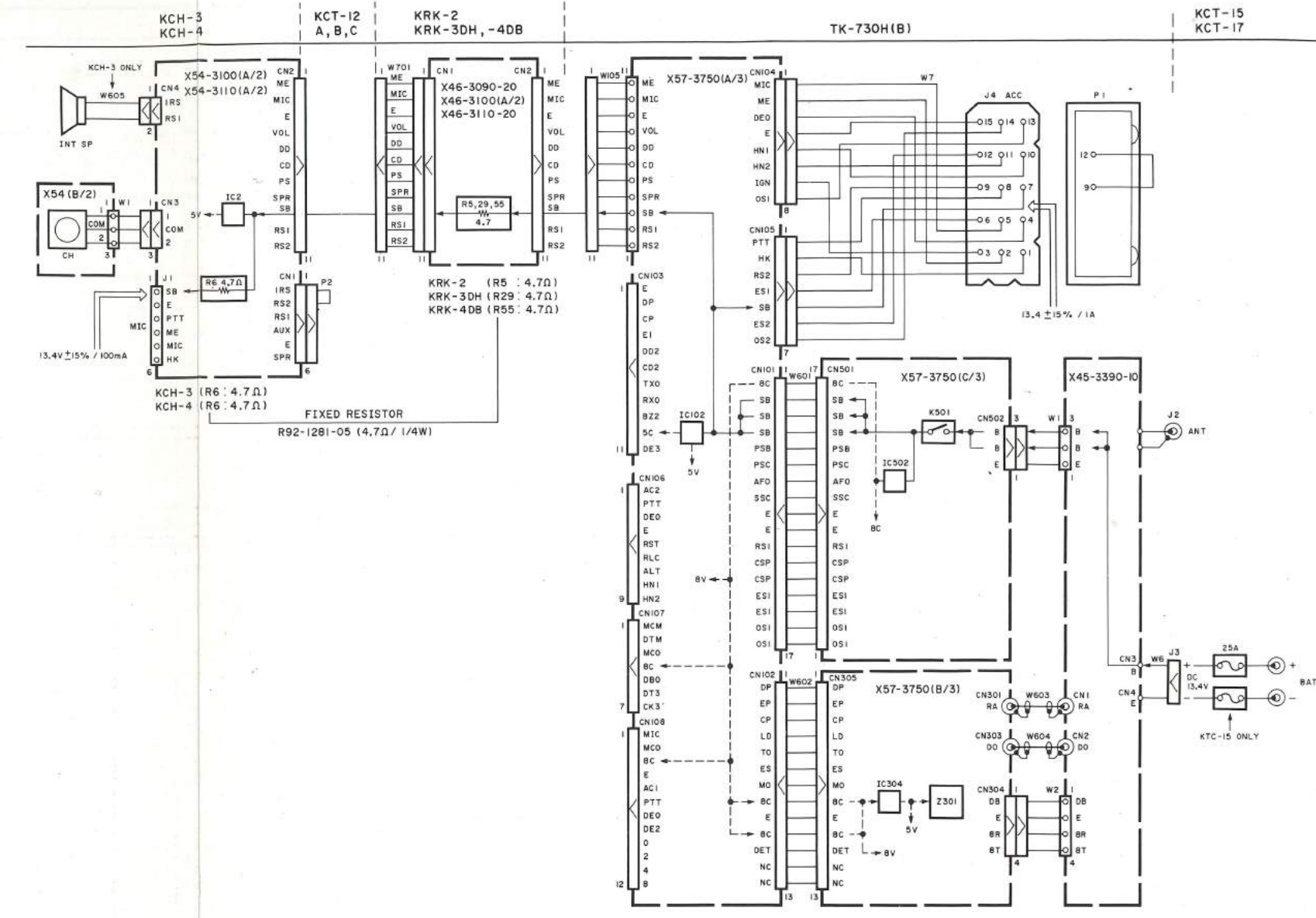
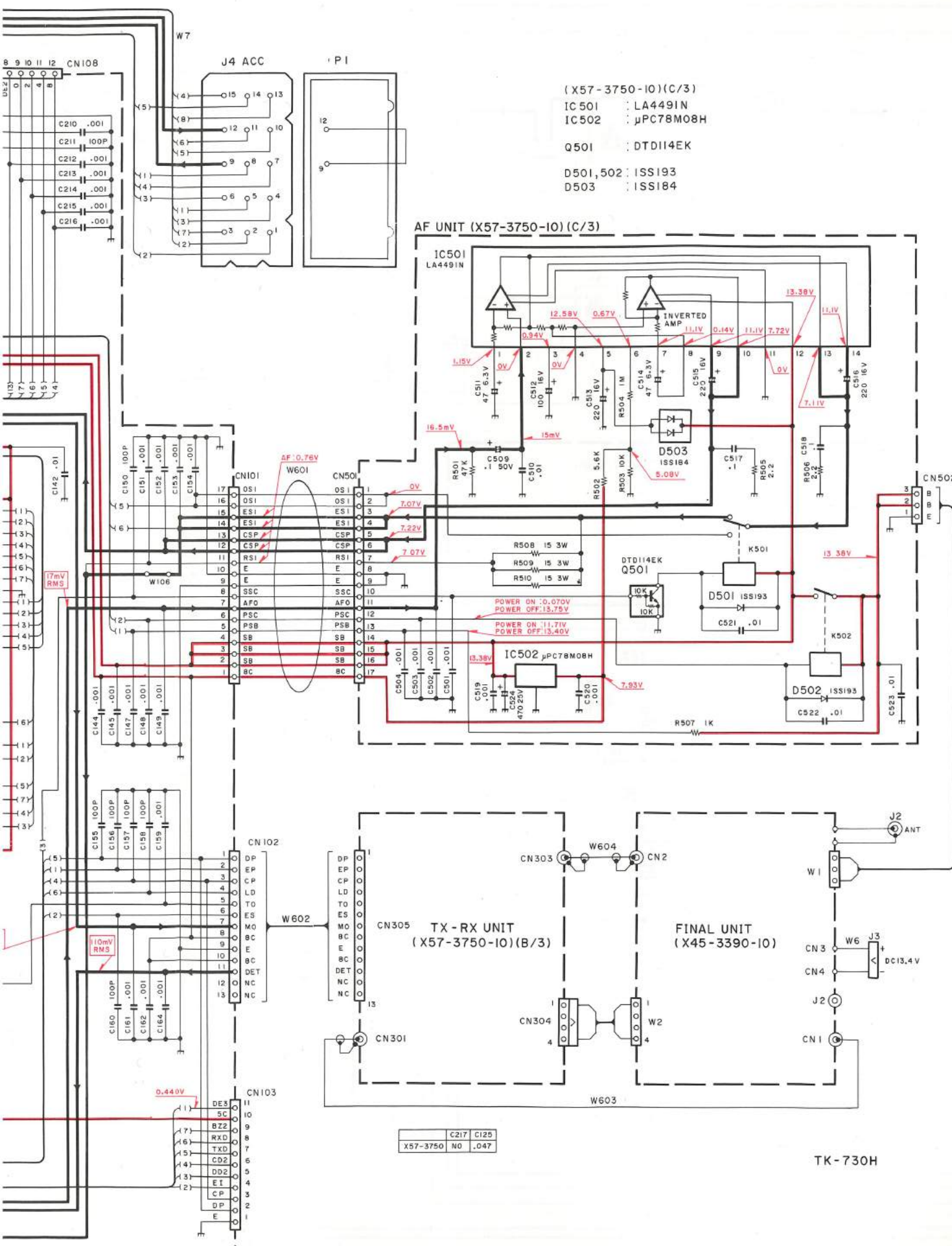

SPECIFICATIONS

GENERAL

Frequency Range	150 to 174MHz
Number of Channel	32 semi-duplex channels (KCH-3 basic front panel model modifiable to 99 channels with KCH-5, KCH-4 full featured front panel model modifiable to 160 channels with KCH-5)
Channel Spacing	30kHz (PLL channel step 5kHz)
Input Voltage	13.4V DC negative ground
Current Drain	0.6A on standby 2.2A on receive (at 13W) 25A on transmit
Duty Cycle	Transmitter 20%
Temperature Range	-30°C to +60°C (-22°F to +140°F)
Dimensions & weight	7.05" (179mm) W x 2.36" (60mm) H x 12.97" (329.5mm) D, 8.38lbs (3.8kg) : with KCH-3 or KCH-4

RECEIVER (Measurements made per EIA standard EIA-204-C)

RF Input Impedance	50Ω
Sensitivity (EIA 12dB SINAD)	0.25μV
Modulation Acceptance	±7kHz
Selectivity	-85dB
Intermodulation	-80dB
Spurious and Image Rejection	-90dB
Audio Power Output	13W at 4Ω less than 5% distortion
Frequency stability	±0.0005% from -30°C to +60°C (±0.0002% option)
Channel Frequency Spread	24MHz (150 to 174MHz)

TRANSMITTER (Measurements made per EIA standard EIA-152-B)

RF Power Output	110W adjustable to 45W
RF Output Impedance	50Ω
Spurious and Harmonics	-80dB
Modulation	F3E, F1D, F2D
FM Noise	-53dB
Microphone Impedance	Low impedance
Audio Distortion	Less than 2% at 1000Hz
Frequency Stability	±0.0005% from -30°C to +60°C (±0.0002% option)
Channel Frequency Spread	24MHz (150 to 174MHz)

APPLICABLE (MIL-STD)

	MIL810-C	MIL810-D
Low Pressure	500.1/Procedure 1	500.2/Procedure 1
High Temperature	501.1/Procedure 1,2	501.2/Procedure 1,2
Low Temperature	502.1/Procedure 1	502.2/Procedure 1,2
Temperature Shock	503.1/Procedure 1	503.2/Procedure 1
Solar Radiation	505.1/Procedure 1	505.2/Procedure 1
Rain	506.1/Procedure 2	506.2/Procedure 2
Humidity	507.1/Procedure 2	507.2/Procedure 2
Salt Fog	509.1/Procedure 1	509.2/Procedure 1
Dust	510.1/Procedure 1	510.2/Procedure 1
Vibration	514.2/Procedure 8,10	514.3/Procedure 1
Shock	516.2/Procedure 1,2,3,5	516.3/Procedure 1,3,4,5,6

DEPARTMENT OF AGRICULTURE, EIA (VIBRATION)

Meets department of agriculture, forest service specifications for VIBRATION, referencing EIA standard EIA-152B and EIA-204C.

KENWOOD CORPORATION

Alive Mitake, 2-5, 1-chome Shibuya, Shibuya-ku, Tokyo 150, Japan

KENWOOD U.S.A. CORPORATION

COMMUNICATIONS & TEST EQUIPMENT GROUP

P.O. BOX 22745, 2201 East Dominguez St., Long Beach, CA 90801-5745, U.S.A.

KENWOOD ELECTRONICS DEUTSCHLAND GMBH

Rembrücker Str. 15, 6056 Heusenstamm, Germany

KENWOOD ELECTRONICS BENELUX N.V.

Mechelsesteenweg 418 B-1930 Zaventem, Belgium

TRIO-KENWOOD FRANCE S.A.

13, Boulevard Ney, 75018 Paris, France

TRIO-KENWOOD U.K. LIMITED

KENWOOD House, Dwight Road, Watford, Herts., WD1 8EB United Kingdom

KENWOOD ELECTRONICS NEDERLAND B.V.

Amsterdamseweg 35, 1422 AC Uithoorn, The Netherlands

KENWOOD LINEAR S.p.A.

20125, Milano-via Arbe, 50, Italy

KENWOOD ESPAÑA S.A.

Bolivia, 239-08020 Barcelona, Spain

KENWOOD ELECTRONICS AUSTRALIA PTY. LTD.

(A.C.N. 001 499 074)

P.O. Box 504, 8 Figtree Drive, Australia Centre, Homebush, N.S.W. 2140, Australia

KENWOOD & LEE ELECTRONICS, LTD.

Unit 3712-3724, Level 37, Tower one Metroplaza, 223 Hing Fong Road, Kwai Fong, N.T., Hong Kong

KENWOOD ELECTRONICS CANADA INC.

6070 Kestrel Road, Mississauga, Ontario, Canada L5T 1S8