

TKR-720/N/A

SERVICE MANUAL

REVISED

© 1994-7 PRINTED IN JAPAN
B51-8088-10(N)750

This service manual is the same as the service manual (B51-8088-00) for TKR-720 (K,M,K2,M2) destinations except that this manual contains new items for (TKR-720N : M,M2, TKR-720A : M,M2) destinations.

Use it together with the previous service manual (B51-8088-00).

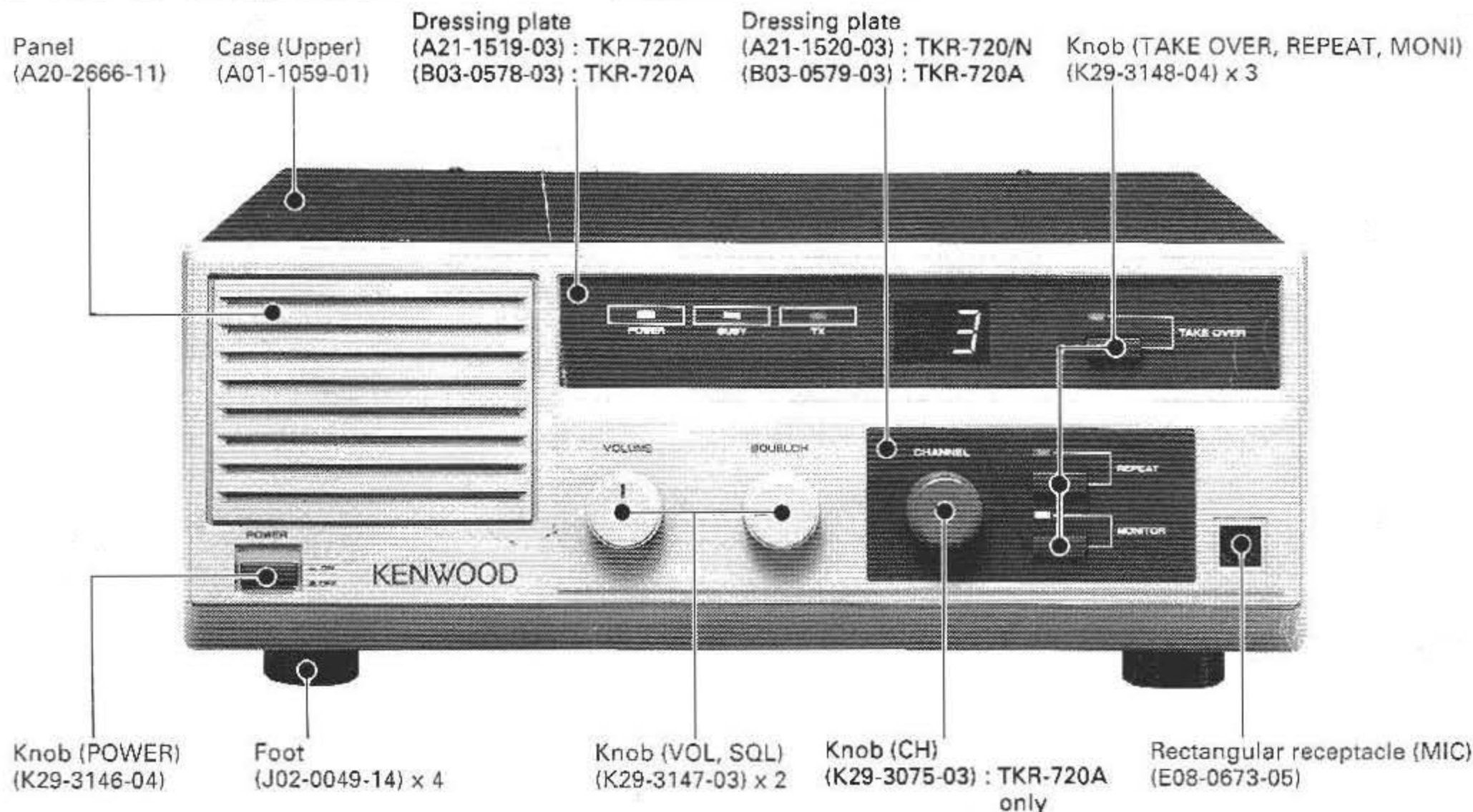

Photo is TKR-720A type.

CONTENTS

GENERAL	2	RX VCO : Z2 (X58-3290-XX)	68
SYSTEM SET-UP	4	TX VCO : Z5 (X58-3790-XX)	69
INSTALLATION	5	MIC AMP : Z7 (X59-3210-10)	70
CONVERSION	8	IF : Z8 (X59-3220-10)	71
DISASSEMBLY FOR REPAIR	11	BPF/VCA : Z9 (X59-3230-10)	72
BLOCK DIAGRAM	17	SIGNALING UNIT (X52-3140-10)	73
CIRCUIT DESCRIPTION	20	AVR UNIT (X43-3040-10)	76
SEMICONDUCTOR DATA	28	DRIVE UNIT (X45-3310-XX)	77
DESCRIPTION OF COMPONENTS	35	FINAL UNIT (X45-3320-XX)	78
PARTS LIST	37	DISPLAY UNIT (X54-3070-XX)	79
EXPLODED VIEW	58	TX-RX UNIT (X57-3760-XX)	81
PACKING	60	SCHEMATIC DIAGRAM	83
ADJUSTMENT	61	TERMINAL FUNCTION	87
PC BOARD VIEWS / CIRCUIT DIAGRAMS		KMC-9 (BASE MICROPHONE)	89
RX PLL : Z1, TX PLL : Z4 (X58-3140-XX)	67	SPECIFICATIONS	BACK COVER

GENERAL

INTRODUCTION

SCOPE OF THIS MANUAL

This manual is intended for use by experienced technicians familiar with similar types of commercial grade communications equipment. It contains all required service informations for the equipment and is current as of the publication date. Changes which may occur after publication are covered by either Service Bulletins of Manual Revisions. These are issued as required.

ORDERING REPLACEMENT PARTS

When ordering replacement parts or equipment information, the full part identification number should be included. This applies to all parts : components, kits, or chassis. If the part number is not known, include the chassis or kit number of which it is a part, and a sufficient description of the required component for proper identification.

PERSONNEL SAFETY

The following precautions are recommended for personnel safety :

- DO NOT transmit if someone is within two feet (0.6 meter) of the antenna.
- DO NOT transmit until all RF connectors are verified secure and any open connectors are properly terminated.
- SHUT OFF and DO NOT operate this equipment near electrical blasting caps or in an explosive atmosphere.
- All equipment should be properly grounded before power-up for safe operation.
- This equipment should be serviced by a qualified technician only.
- Be careful against electric hazard, for the commercial power supply is being applied to the internal circuitry of the radio even when the Power switch is OFF.

FCC COMPLIANCE AND TYPE NUMBERS

Type acceptance number	Frequency range	Compliance
ALHTKR-720-1	150 to 174MHz	Part 22, 74 and 90

1. POWER-UP

To push on the radio. The POWER indicator will illuminate to indicate power is ON.

2. TO RECEIVE

Operation	Procedure
1. Disable QT If so programmed.	Push on MONITOR switch.
2. Unsquench radio	Turn SQUELCH control counter-clockwise until noise is heard.
3. Set VOLUME control	Adjust VOLUME control for a normal listening level.
4. Set SQUELCH control	Advance SQUELCH control clockwise until noise just stops.
The radio will now receive all traffic on the selected channel.	
5. Enable QT If so programmed.	Press the MONITOR switch to OFF.
You will now hear messages for your system only.	

3. TO TRANSMIT (In case a microphone is connected)

Operation	Procedure
1. Disable QT	Depress MONITOR switch on front panel or microphone.
2. LISTEN	DO NOT TRANSMIT if channel is in use.
3. Key transmitter	Press and hold the microphone PTT switch. The Red LED on the front panel will glow indicating the transmitter is ON.
4. Transmit message	Hold microphone at about 2 inches distance and speak at a normal voice level. Keep transmissions brief.
5. Receive reply	Release the microphone PTT switch.
6. Enable QT at end of the conversation If so programmed.	Depress MONITOR to the out position.

GENERAL

4. DURING OPERATION OF REPEATER

Operation	Procedure
1. Enable repeat	Press the REPEAT switch to ON.
2. Start of repeat	When a signal including the object tone signal (provided that it has been programmed) is input and if its level is higher than the preset squelch level, a signal modulated by the set tone signal (provided that it has been programmed) and received audio signal is transmitted.
3. End of repeat	When the received signal disappears, the transmission is stopped after the set period of time. There indicator lights while the signal is transmitted.
4. Disable repeat	Press the REPEAT switch again to OFF.

PRE-INSTALLATION CONSIDERATIONS

1. UNPACKING

Unpack the radio from its shipping container and check for accessory items. If any item is missing, please contact KENWOOD immediately.

2. LICENSING REQUIREMENTS

Federal regulations require a station license for each radio installation (mobile or base) be obtained by the equipment owner. The licensee is responsible for ensuring transmitter power, frequency, and deviation are within the limits permitted by the station license.

Transmitter adjustments may be performed only by a licensed technician holding an FCC first, second or general class commercial radiotelephone operator's license. There is no license required to install or operate the radio.

3. PRE-INSTALLATION CHECKOUT

3-1. Introduction

Each radio is adjusted and tested before shipment. However, it is recommended that receiver and transmitter operation be checked for proper operation before installation.

3-2. Testing

The radio should be tested complete with all cabling and accessories as they will be connected in the final installation. Transmitter frequency, deviation, and power output should be checked, as should receiver sensitivity, squelch operation, and audio output. QT equipment operation should be verified.

4. PLANNING THE INSTALLATION

4-1. General

Inspect the vehicle and determine how and where the radio antenna and accessories will be mounted.

Plan cable runs for protection against pinching or crushing wiring, and radio installation to prevent overheating.

4-2. Antenna

When an outdoor antenna is to be installed, select an unobstructed position with good visibility.

The VSWR of the antenna should be no more than 2.

Select a coaxial cable with as small loss as possible, and its length should be as short as possible.

4-3. Radio

Install the radio on a rack using rack-mount brackets, or on a flat surface that can withstand its weight. Do not install the radio in a place subject to direct sunlight or near heating equipment. Avoid wet place, and install it in a well-ventilated place.

4-4. AC power supply

This unit has been designed for use exclusively with commercial AC power supply. As the rated current for transmission output attains about 2A, connect the unit to a wall outlet that can handle this current with margin.

SERVICE

This radio is designed for easy servicing. Refer to the schematic diagrams, printed circuit board views, and alignment procedures contained in this manual.

SYSTEM SET-UP

Preparation : Prepare an EEPROM writer, KPT-20 or KPT-50.

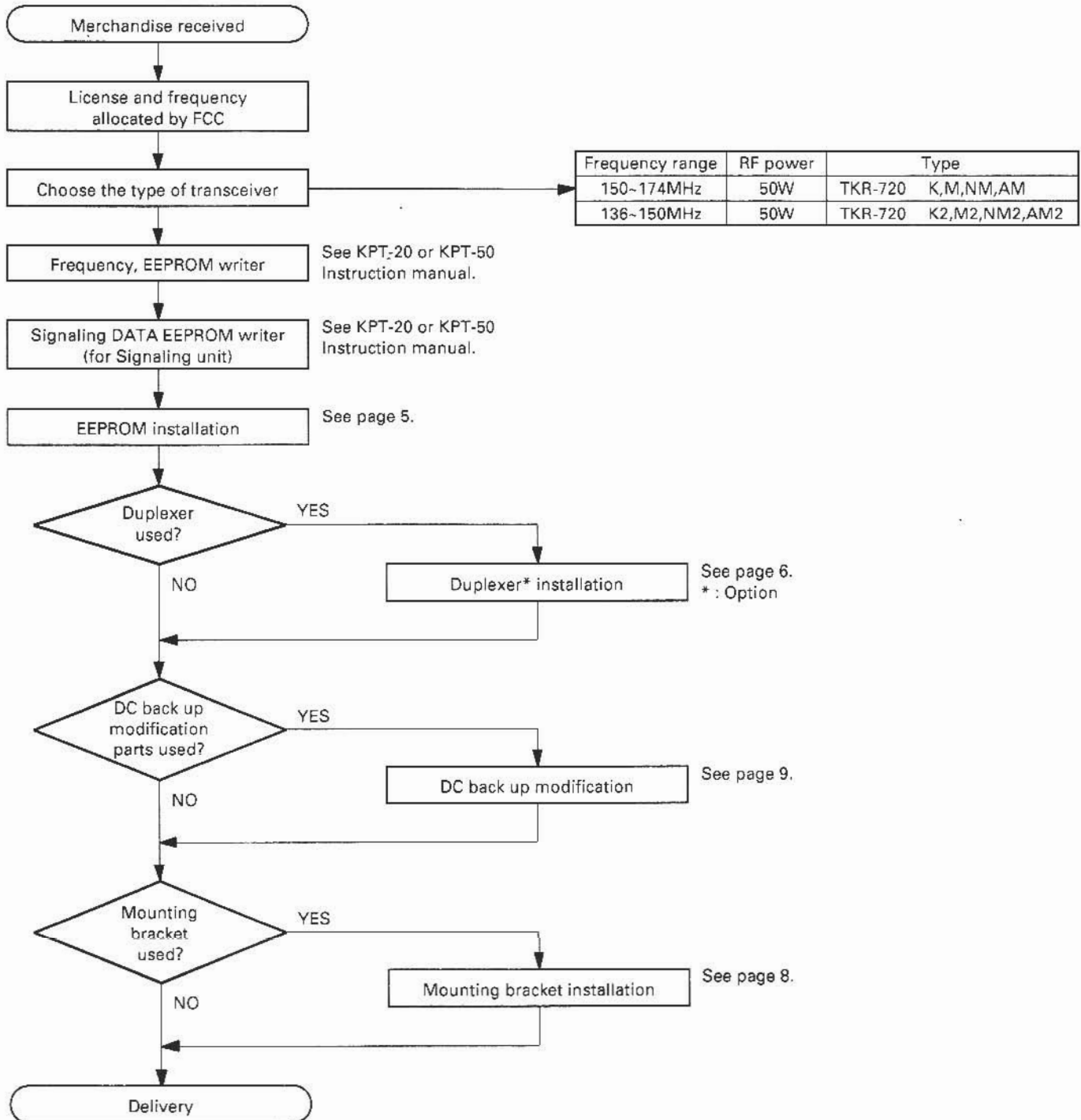

INSTALLATION

Installing the EEPROM of Signaling Unit

Note : EEPROM is inserted into the Signaling unit of the TKR-720. Install it after writing the data using the ROM writer (KPT-20 or KPT-50).

1. Remove the 10 screws (❶) holding the upper case to remove the upper case.

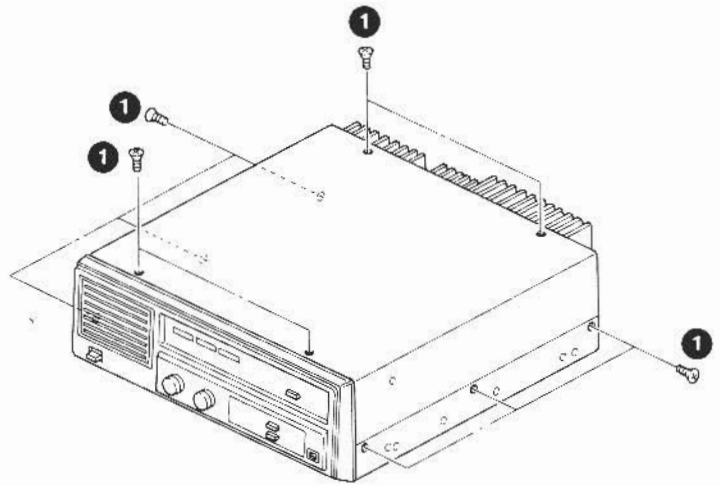

2. Remove the 11 screws (❷) retaining the shield cover to remove the shield cover.
3. Insert the EEPROM (❸) on which the data has been written into the IC socket (IC10) on the Signaling unit.

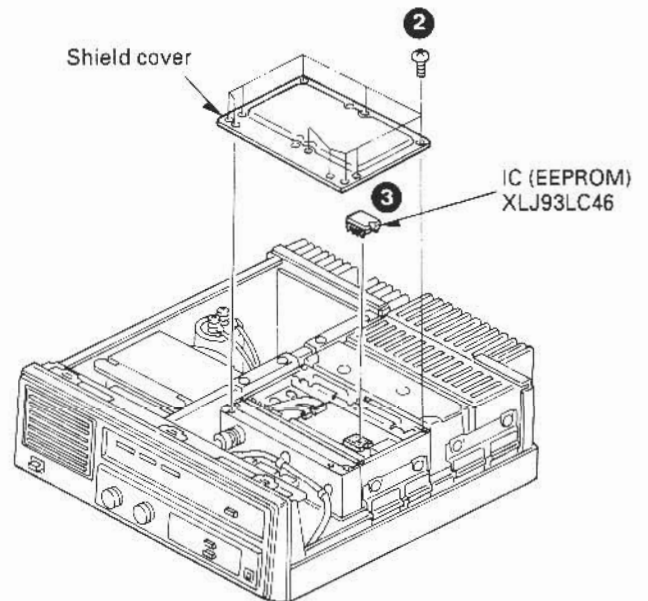

INSTALLATION

Installing the Duplexer

Note : When installing the duplexer in the TKR-720, use the either of the following products ;

1. CELWAVE (USA), 144 to 174MHz (PD636-6A)
2. Installation kit (KCT-11) : option

Installing fitting : J21-4339-03	1pc
M-M conversion receptacle : E04-0183-05	1pc
Lead with connector : E37-0120-08	3pc
Truss screw (M4 x 2) : N09-0704-05	6pc
Tapping screw (M3 x 8) : N87-3008-46	2pc

1. Remove the 10 screws (❶) holding the upper case to remove the upper case.
2. Remove the 4 screws (❷) holding the lower case to remove the lower case.
3. After removing the upper and lower cases, turn the set upside down, as shown in the figure (❸).
4. Remove the coaxial cables (❹) connected to the RX antenna connector.
5. Remove the bushing (❺) in the hole in the rear panel, insert the M-type receptacle (❻) into the hole (longer side facing in), and secure it with two tap-tight screws (❼).
6. Release the coaxial cable (❹) from the wire bands (❽ and ❾) and secure it with the wire bands (❿ and ⓫) on the opposite side.

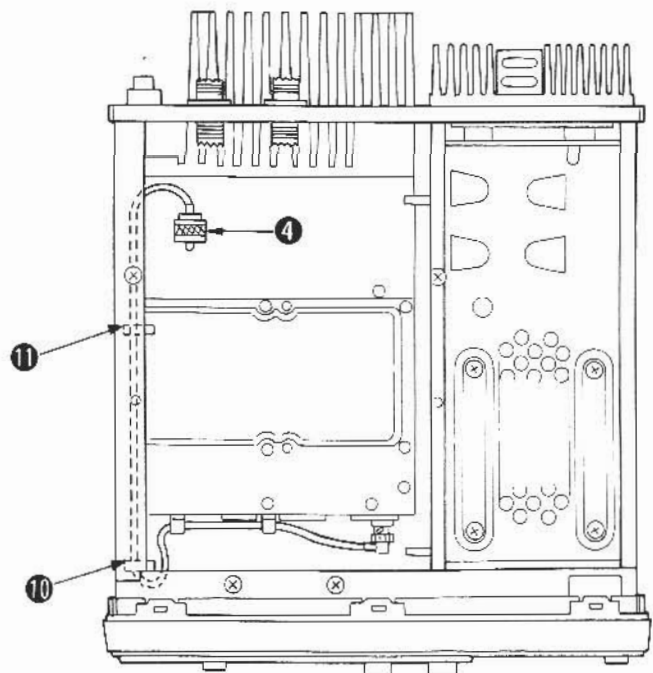
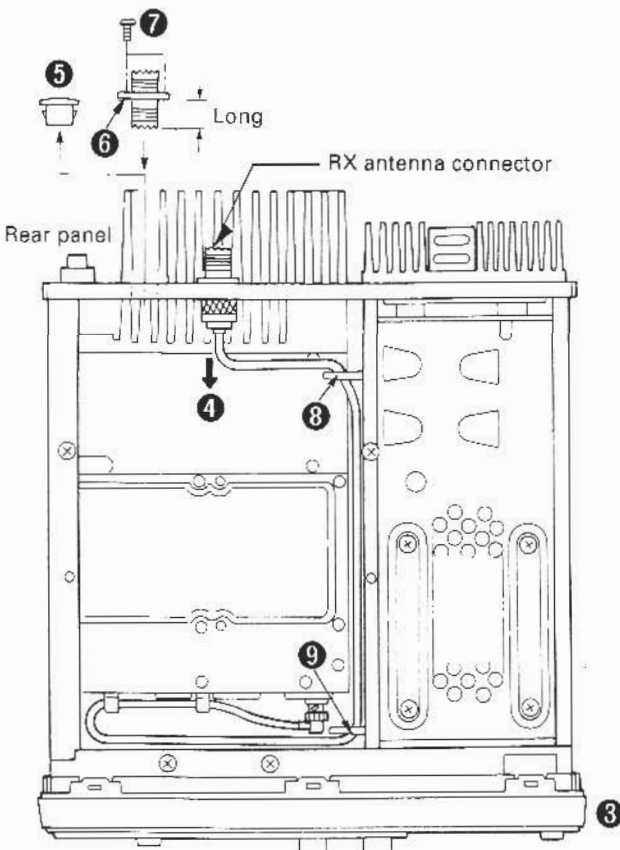
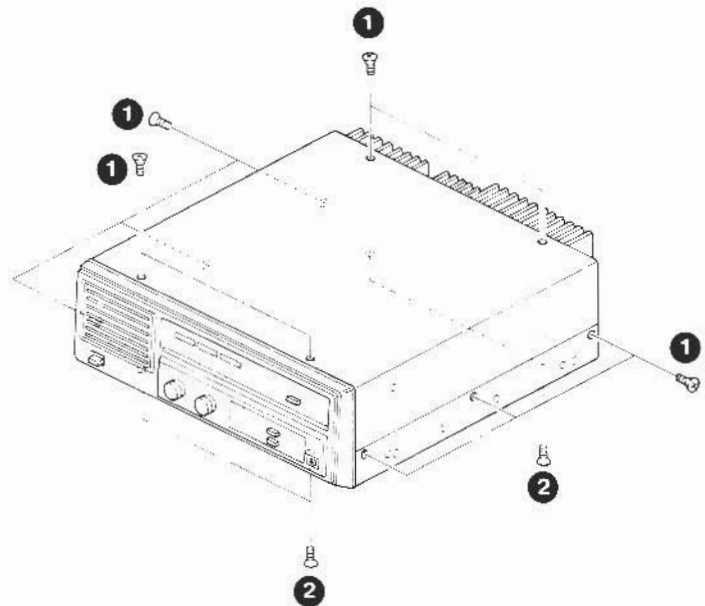

INSTALLATION

7. Secure the installation fitting (12) supplied with the KCT-11 to the duplexer (13) with two screws (14), and put it in position in the TKR-720 without securing it.
8. Connect the coaxial cable (4) to the RX connector of the duplexer. Connect the coaxial cables supplied with the KCT-11 to the TX ANT-(15) and duplexer TX connector (16) via the M-type receptacle (17). Connect another cable to the duplexer ANT connector (18) and TKR-720 duplexer antenna connector (19).
9. After connecting the coaxial cables, secure the duplexer (13) to the TKR-720 with four screws (20).

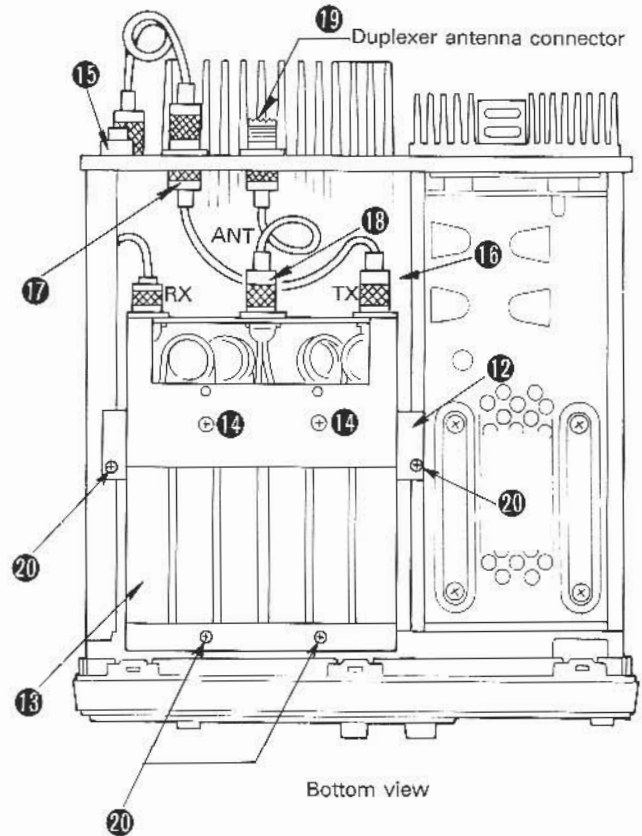

Note : The input/output connectors of the duplexer manufacture by CELWAVE are located as shown in the figure. Pay attention when connecting the connectors.

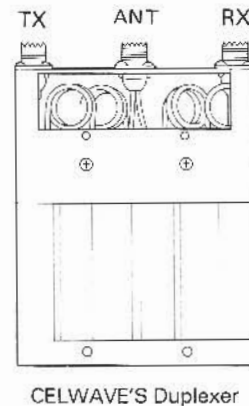

Note : When making adjustments after installing the duplexer, remove the front panel and hold down the sub-panel (21), then perform adjustments from the adjusting holes (22).

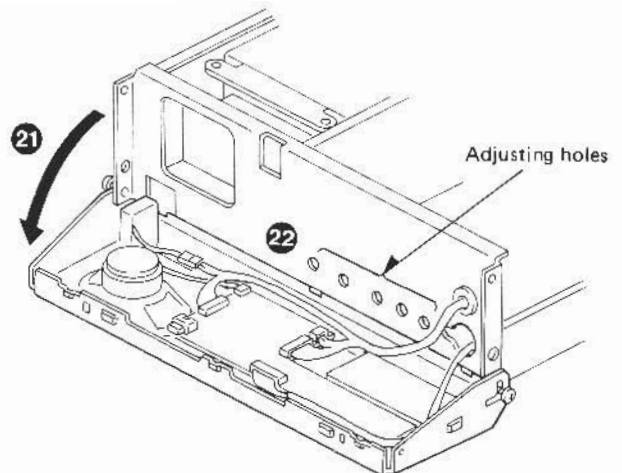

TKR-720/N/A

INSTALLATION / CONVERSION

Attaching the Rack-mount Brackets (for EIA racks)

The brackets and screws are optional.

Brackets : J21-4250-04 (Common for left and right)

Screw : N09-0704-05 (Use 2 screws per bracket)

1. Attach the 2 brackets (❶) using 4 screws (❷).

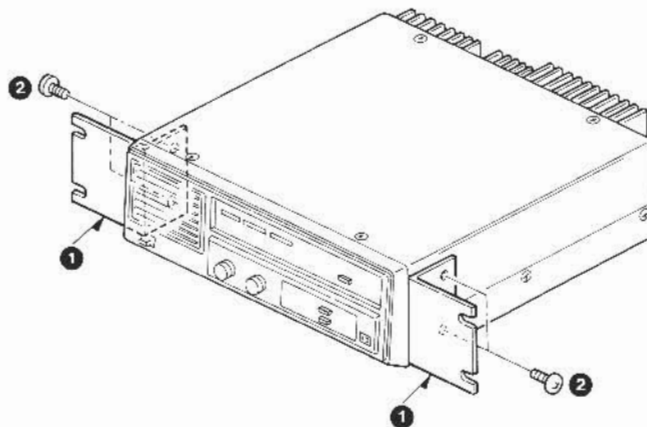

2. When the TKR-720 is to be mounted vertically :
Attach 4 brackets (❸), using 8 screws (❹), to be side of the bottom panel.

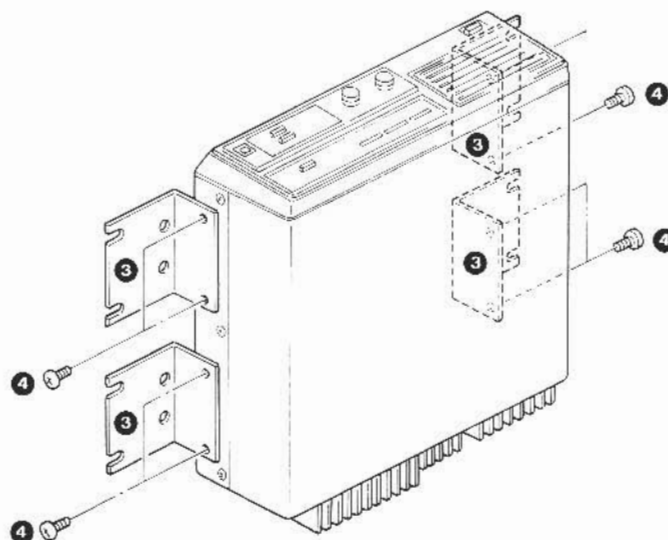

CONVERSION

Signaling Wait Mode Setting Method

• What is the signaling wait mode?

The KPT-20 or KPT-50 can write signaling codes into channels 1 to 16. The codes written in up to eight channels can be used at a time, and the codes written in channels 1 to 8 are effective. One or more signaling codes to be waited for in the repeater mode can be selected. They can be changed by W4 of the Signaling unit (X52-3140-10).

• Wait mode setting method

Ref. No.	Function	Mode	Setting
W4	Decode change in repeater mode	Short	Two or more codes
		Open	One code

Factory setting : Short

W4 part No. : E31-1448-05

If the signaling wait is one code (W4 : open), the TKR-720/N uses the code written in channel 1, and the TKR-720A uses the signaling code in the displayed channel. If several codes are waited for (W4 : short), the multiple signaling codes written in channels 1 to 8 can be waited for.

Note : This function is available in serial No. 504XXXXX or later, and IC8 (27C256QJESB) or later.

SIGNALING UNIT (X52-3140-10)

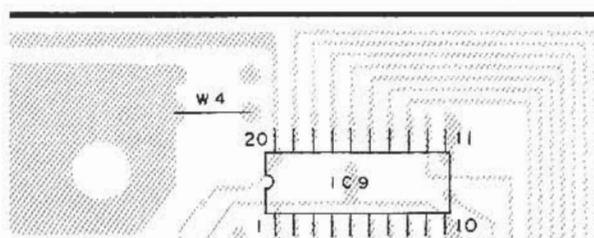

CONVERSION

Modification of the DC Switching Circuit (For Backup during a Power Failure)

: Excluding TKR-720A (M, M2)

The following parts (optional) are required for the circuit modification.

Diode (S25VB10)	1 pc.
DC cable (E30-2076-15)	1 pc.
Connector with lead wires (E31-3389-15) ...	1 pc.
Connector with lead wires (E31-3455-15) ...	1 pc.
Screw (N87-4014-46)	1 pc.

1. From the cover (**1**) attached to the rear panel, remove the 2 screws (**2**) and take off the cover.

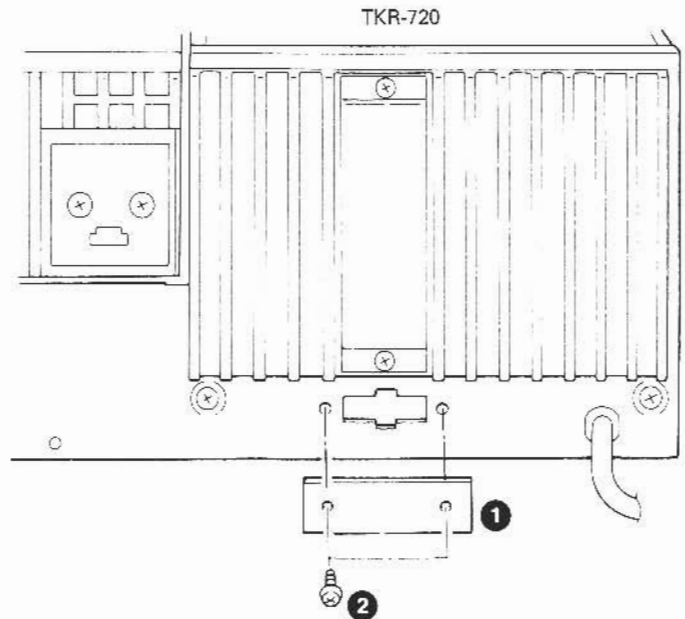

2. Insert the connector with lead wires (**3**) into the hole on the rear panel (**4**) (so that the red lead is on the right).
3. Place the diode (**5**) so that its notch faces the direction shown in the illustration, and attach it using a screw (**6**).
4. Disconnect the connector (**7**) from the OUT terminal of the AVR unit, and connect its lead wire to pin 1 of the diode (**5**).

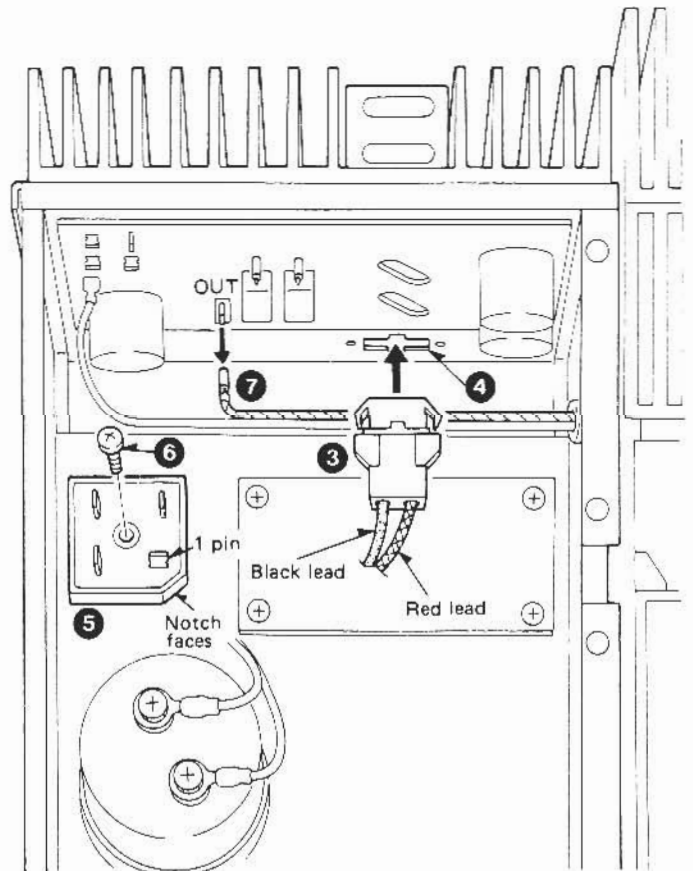

CONVERSION

5. Connect the optional connector with lead wires (**8**) to the OUT terminal of the AVR unit and to pin 3 of the diode.
6. Connect the red lead (**9**) of the optional connector with lead wires to pin 2 of the diode, and its black lead (**10**) to the negative (-) terminal of chemical capacitor C101. Do not disconnect the lead wire which has been connected to the C101 negative terminal, but connect the black lead to it.

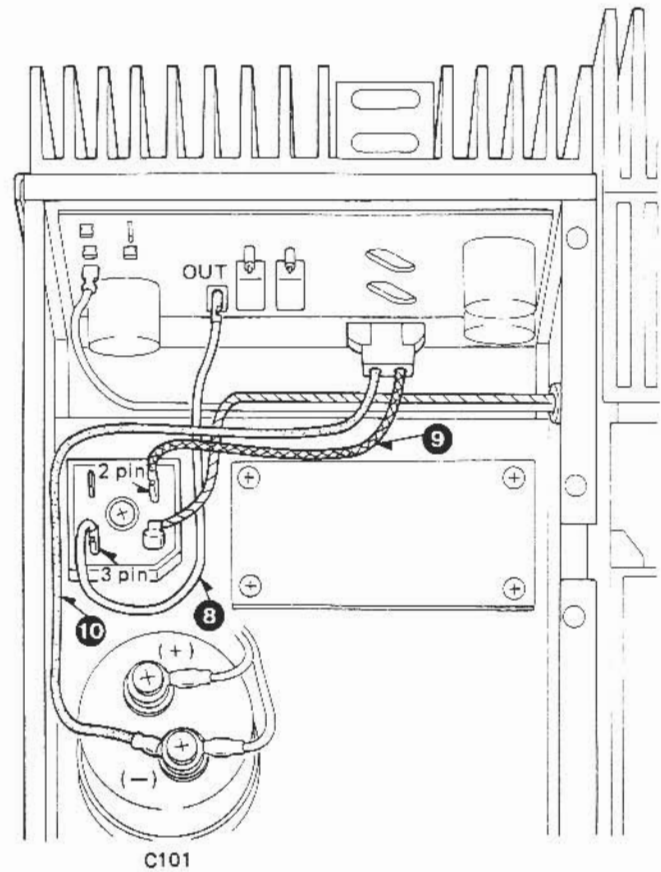

7. Connect the optional DC cable to the connector on the rear panel (**11**).

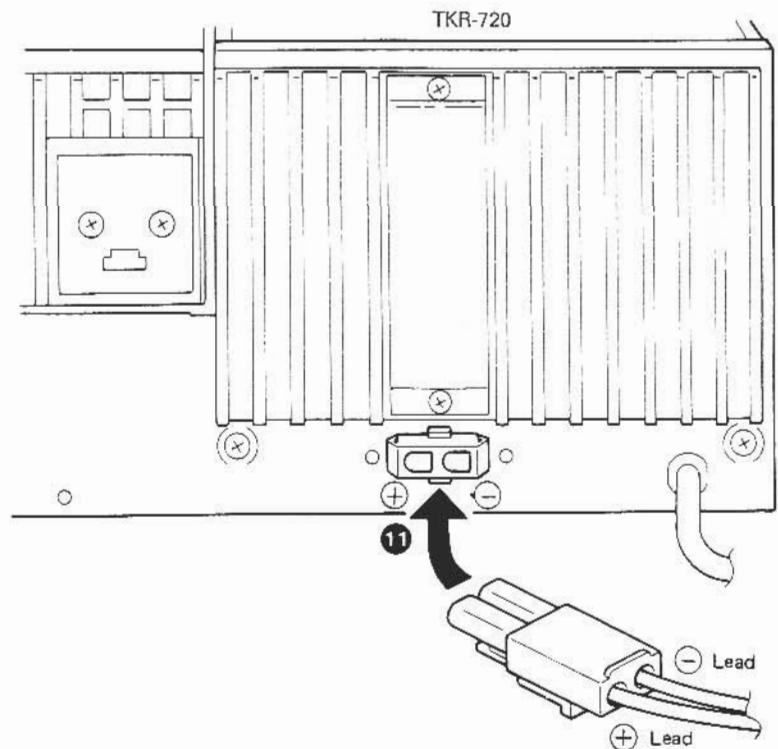

DISASSEMBLY FOR REPAIR

How to Remove the Case

1. Remove the 10 screws (1) holding the upper case to remove the upper case.
2. Remove the 4 screws (2) holding the lower case to remove the lower case.

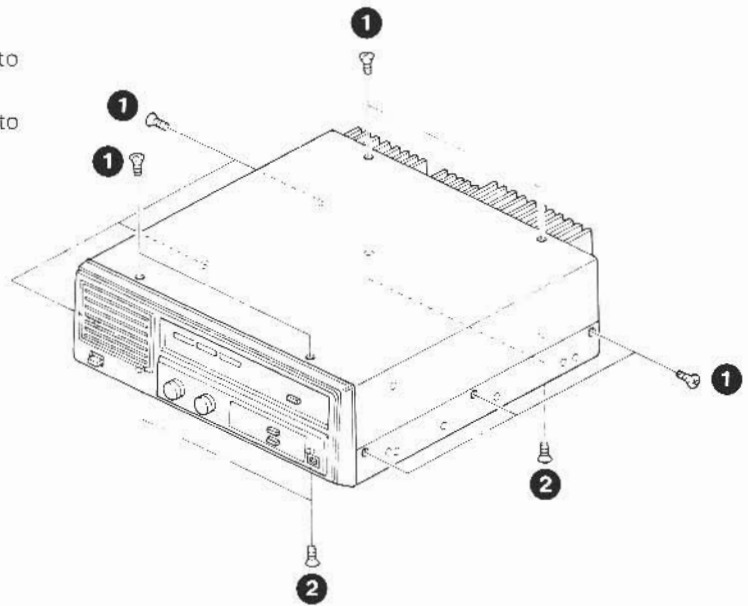

Disassembling the Transmitter/Receiver Section

1. How to remove the transmitter/receiver section

1. Remove the 4 connectors (CN1 to CN4) connected to the panel (Display unit) (1).
2. Remove the 3 screws (2) holding the transmitter/receiver section.
3. While lifting up on the transmitter/receiver section (3), remove the power supply connector (4) and the connector cable (5) connected to the frame, remove the screw (7) securing the transmitter/receiver section, and put the transmitter/receiver section back in place.
4. Remove the 4 screws (8) holding the transmitter/receiver section to the frame to remove the transmitter/receiver section.

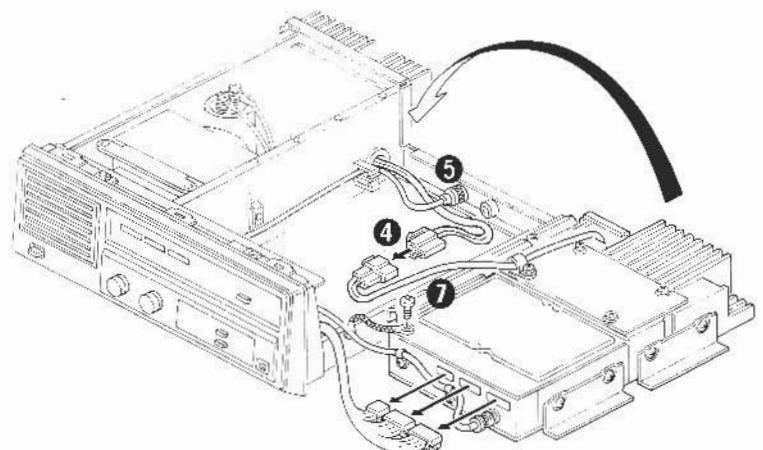
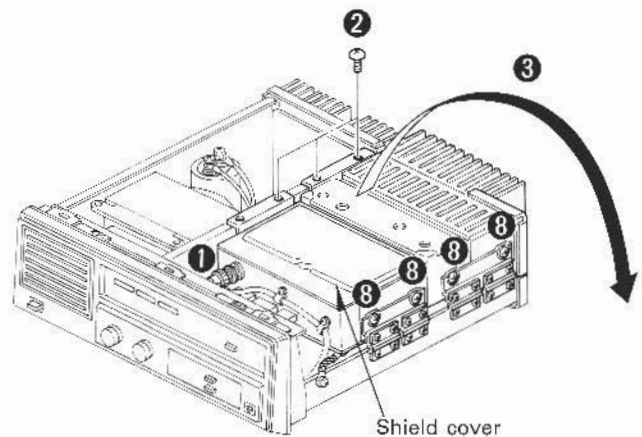

TKR-720/N/A

DISASSEMBLY FOR REPAIR

2. How to remove the TX-RX unit

1. Remove the 6 screws (1) retaining the shield cover to remove the shield cover.
2. Remove the 2 connectors (2) of the Signaling unit and the 6 screws (3) retaining the shield cover to remove the shield cover.
3. Remove the 6 screws (4) retaining the connectors CN2 to CN4.
4. Remove the 11 screws (5) attached on the bottom of the TX-RX unit to remove the shield cover.
5. Remove the 3 connectors CN1 (6), CN8 (7) and CN10 (8) connected to the TX-RX unit.
6. Remove the 4 screws (9) connected between the TX-RX unit and Final unit.
7. Remove the leaf spring fixing the two IC's to the frame with a screwdriver, etc. (10).
8. Remove the 11 screws (11) mounting the TX-RX unit to remove the TX-RX unit.

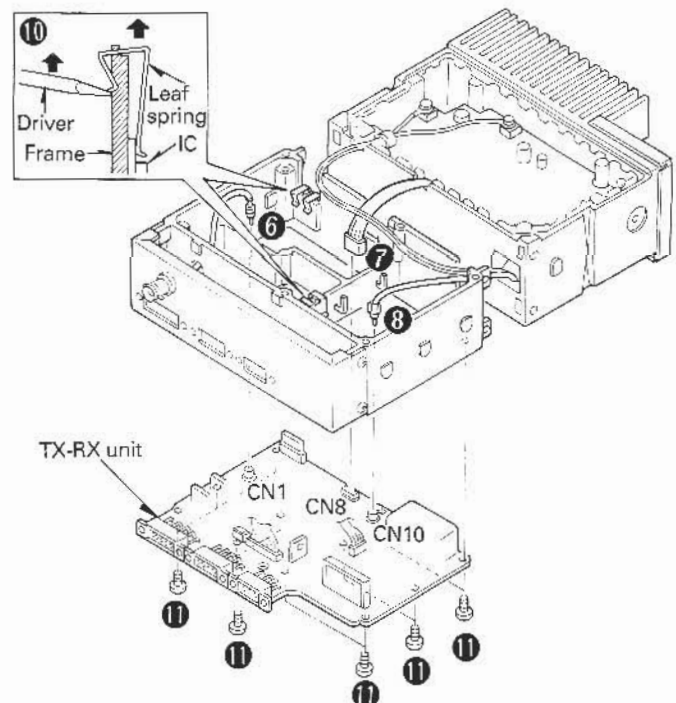
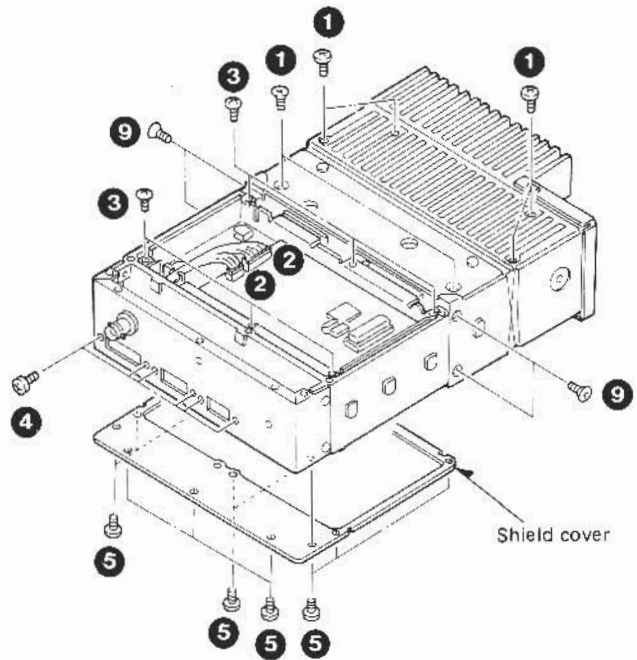

DISASSEMBLY FOR REPAIR

3. Disassembling the Final unit ass'y**• Final unit (X45-3320-XX) side**

1. Remove the soldered part (1) of the VHF connector and that (2) of the lead wire (coaxial cable installed through) from the final unit.
2. Remove the two screws (3) fixing the lead wires of the power connector.
3. Remove the screw (4) securing the cable holder.
4. Remove the two screws (5) fixing the transistor from the heat sink.
5. Remove the 14 screws (6) fixing the final unit from the heat sink to remove the final unit.
6. Remove the two screws (7) fixing the VHF connector to remove the connector from the heat sink.

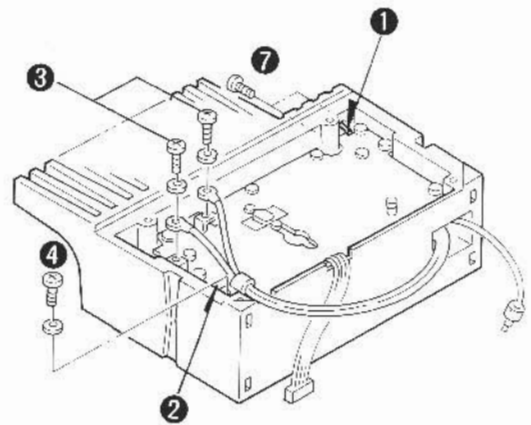

Final unit

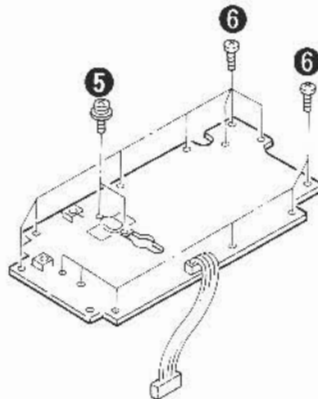
**4. Drive unit (X45-3310-XX) side**

1. Remove the 4 screws (1) retaining the shield cover to remove the shield cover.
2. Remove the soldered part (2) of the lead wire (coaxial cable installed through) from the drive unit.
3. Remove the two screws (3) fixing the module unit from the heat sink.
4. Remove the screw (4) fixing the transistor from the heat sink.
5. Remove the 8 screws (5) fixing the drive unit from the heat sink to remove the drive unit.

Note :When replacing only the module, remove the screws (3) and then remove the four soldered parts of the module terminals (6) to remove the module.

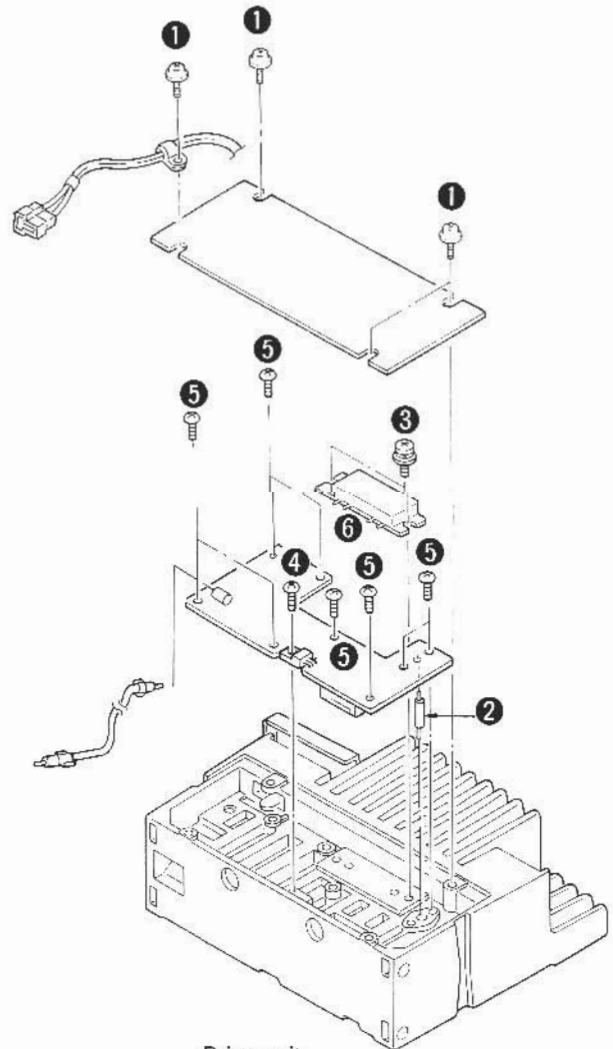

Drive unit

TKR-720/N/A

DISASSEMBLY FOR REPAIR

How to Remove the Panel

1. Pull off the VOLUME, SQUELCH and CHANNEL knobs (1). CHANNEL knob is TKR-720A only.
2. Release the 6 hooks (2) located on the upper and lower section, and holding the sub-panel by pushing them up with your finger. Then remove the sub-panel (3) by pulling it out toward the front.

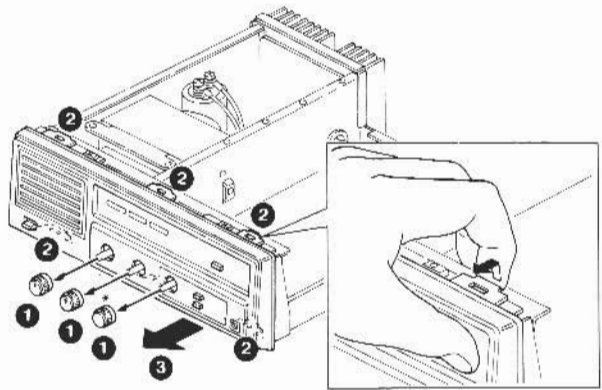

* : TKR-720A only

Disassembling the Sub-panel

1. TKR-720/N
Remove the 2 nuts and 2 washers holding the VOLUME and SQUELCH VRs (1).
TKR-720A
Remove the 3 nuts and 3 washers holding the VOLUME, SQUELCH and CHANNEL VRs (1).
Then remove the 2 screws (2) holding the POWER switch.
2. Remove 2 of the screws (3) holding the sub-panel, and loosen the other 2 screws (4), then tilt the sub-panel toward the front (5).
3. Remove the 5 connectors (6) connected to the Display unit, and remove the connector (7) connected to the POWER switch.
4. Remove the 2 remaining screws (8) holding the sub-panel to remove the sub-panel.

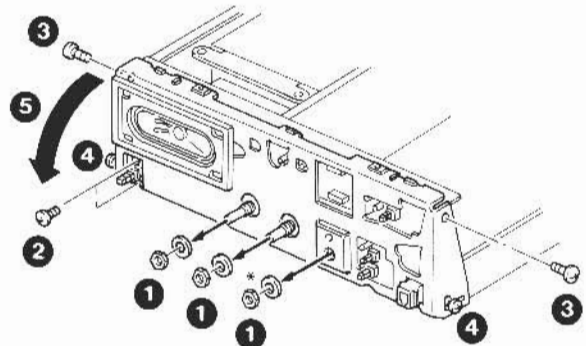

* : TKR-720A only

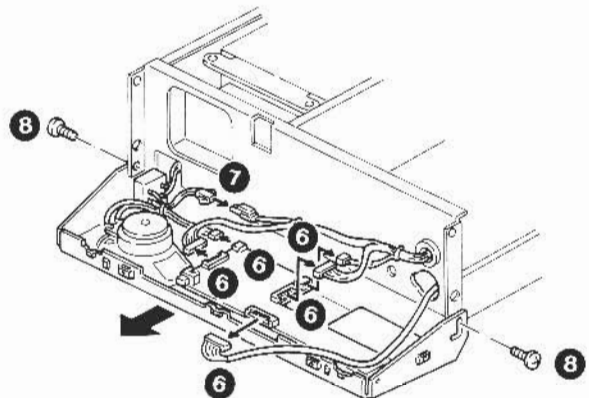

5. Remove the 9 screws (9) holding Display unit (A/4) and (B/4) to the sub-panel, and remove the Display unit (A/4) and (B/4).
6. Remove the 4 screws (10) holding the speaker to the sub-panel to remove the speaker.

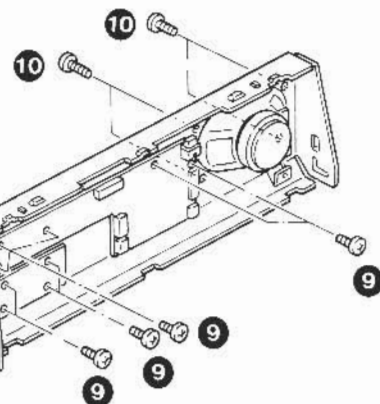

DISASSEMBLY FOR REPAIR

Disassembling the AVR Unit

1. How to remove the AVR unit (X43-3040-10) (A/2)

1. Remove the 8 connectors (1) connected to the AVR unit.
2. Remove the 4 screws (2) holding the AVR unit to the rear panel, and remove the AVR unit from the rear panel.

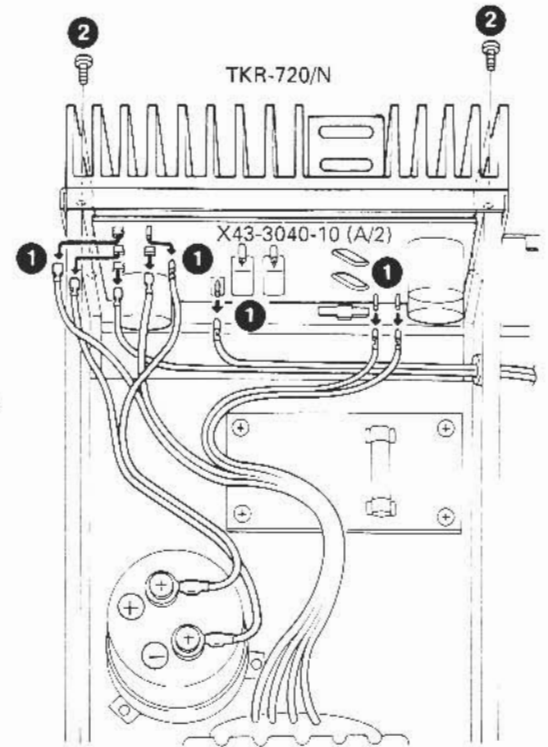
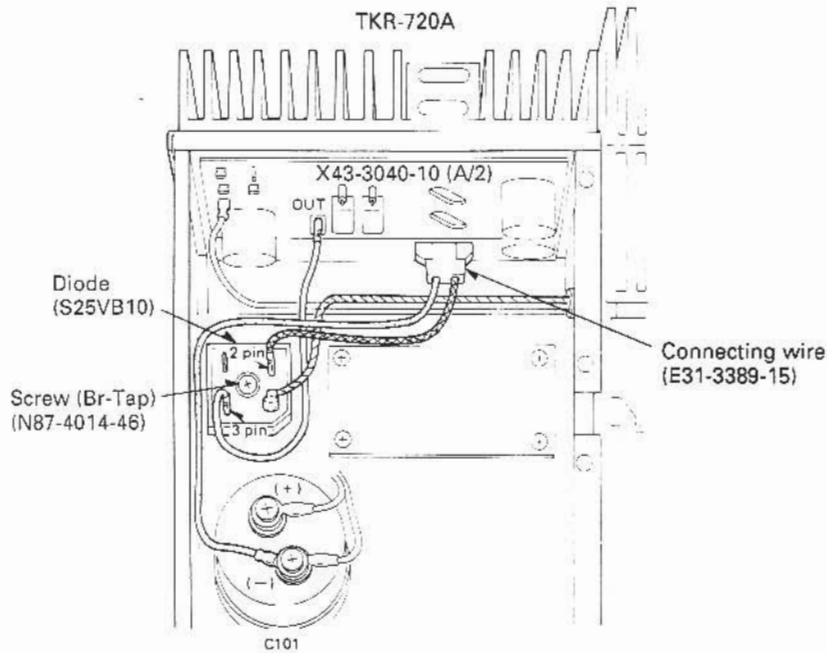

2. Disassembling the AVR unit (X43-3040-10) (A/2)

1. Remove the 4 screws (3) holding the AVR unit.
2. Desolder the 4 wires (4) connected to the bases and emitters of transistors Q5 and Q6.
3. Remove the 2 screws (5) on the radiation cover attached to the heat sink to remove the radiation cover.
4. Remove the 4 screws (6) of the transistors (Q5 and Q6) attached to the heat sink, and remove the AVR unit (A/2).

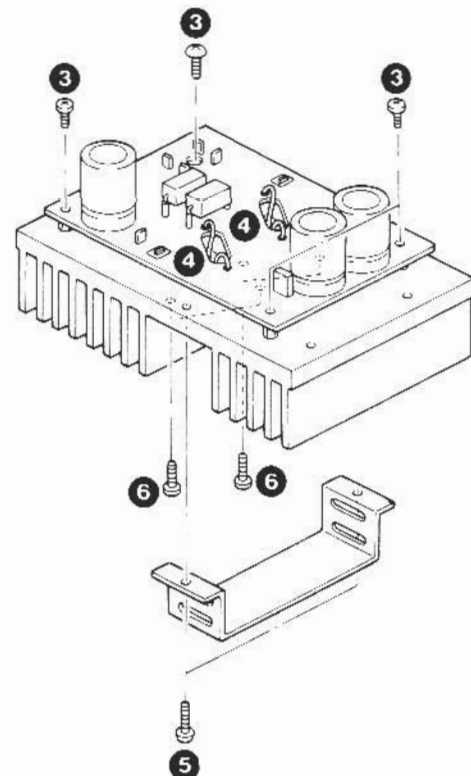

TKR-720/N/A

DISASSEMBLY FOR REPAIR

3. How to remove the AVR unit (X43-3040-10) (B/2) and the electrolytic capacitor (C101)

1. Remove the 4 wires (7) connected to the AVR unit.
2. Remove the 4 screws (8) holding the AVR unit to remove the AVR unit.
3. Remove the 3 screws (9) holding the electrolytic capacitor (C101).

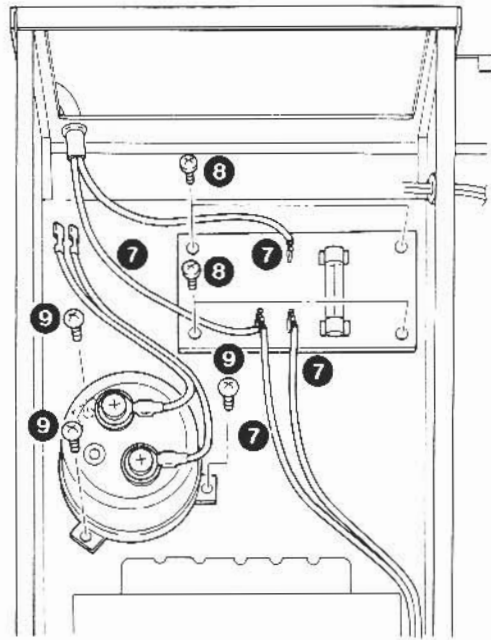

4. How to remove the power transformer

1. Remove the 4 screws (10) holding the power transformer to the bottom plate, and remove the power transformer.

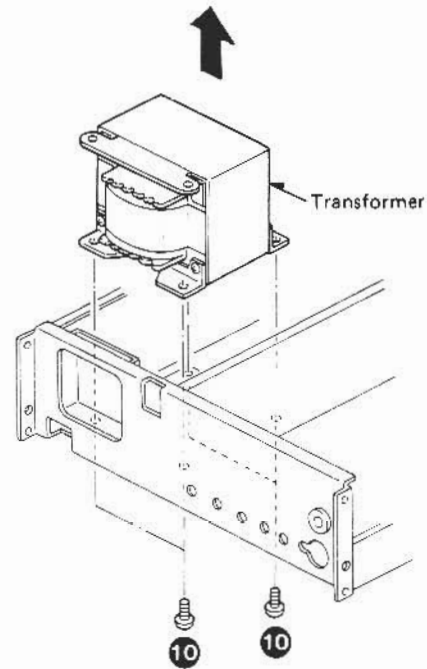

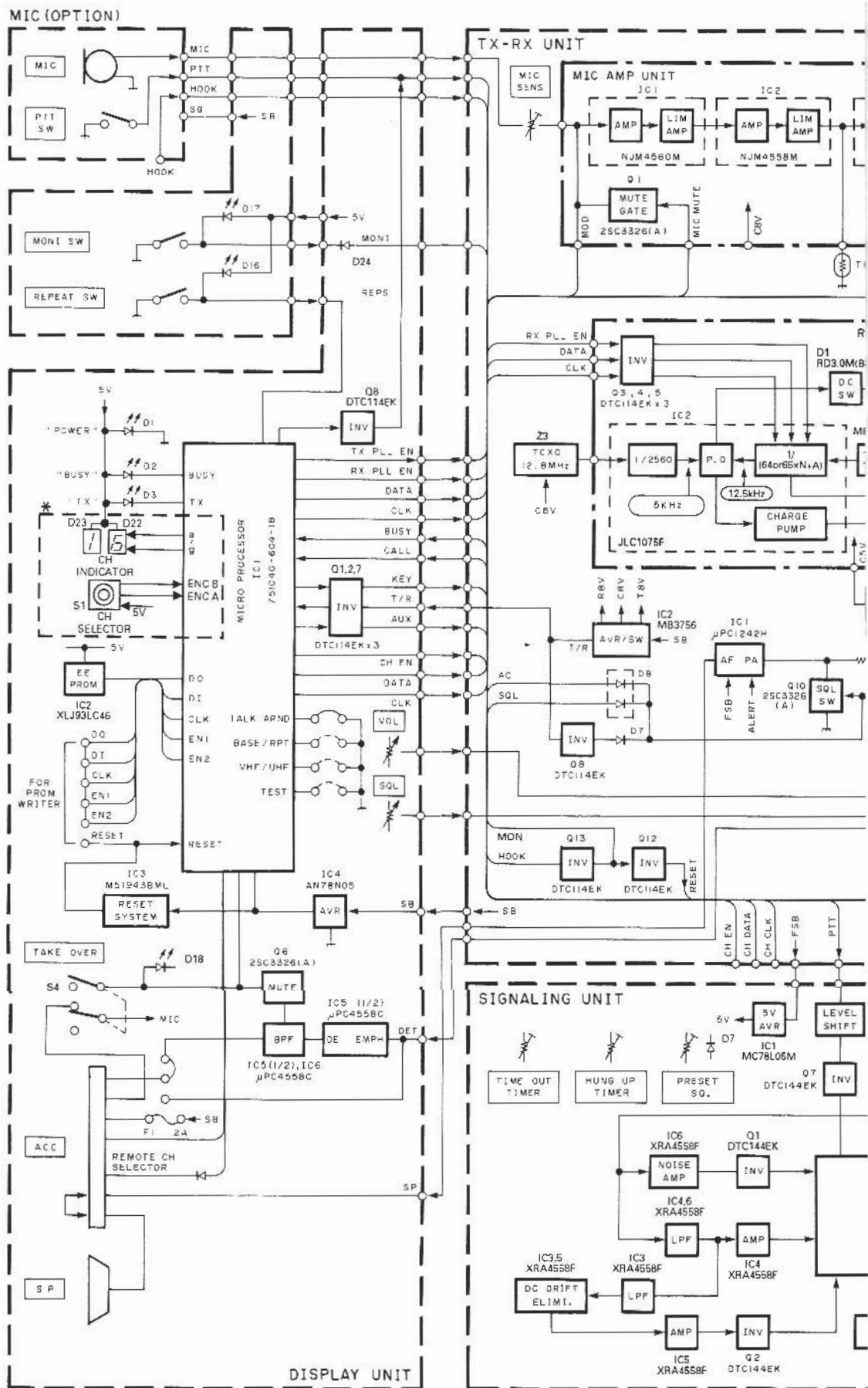

TKR-720/N/A

BLOCK DIAGRAM

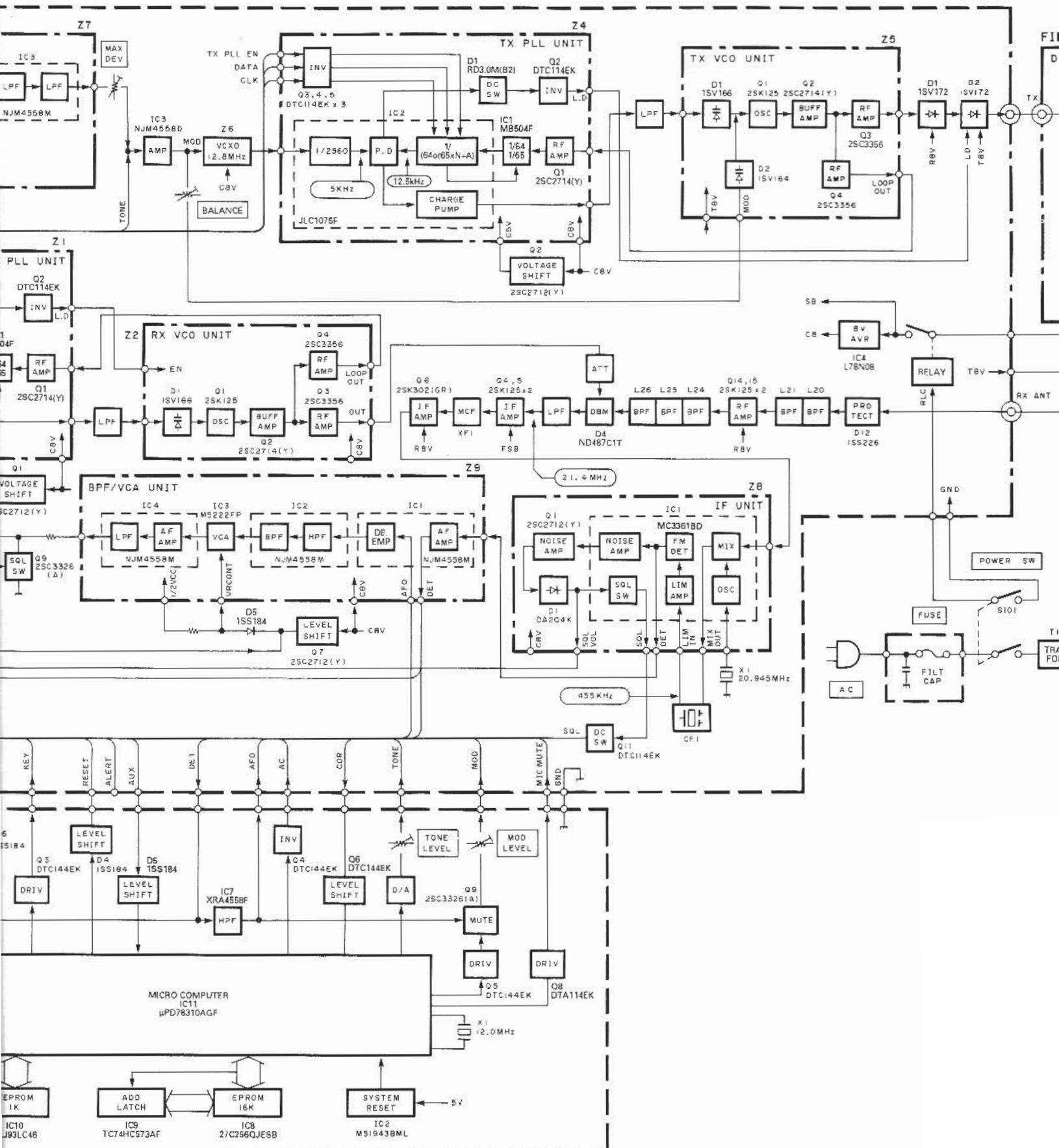

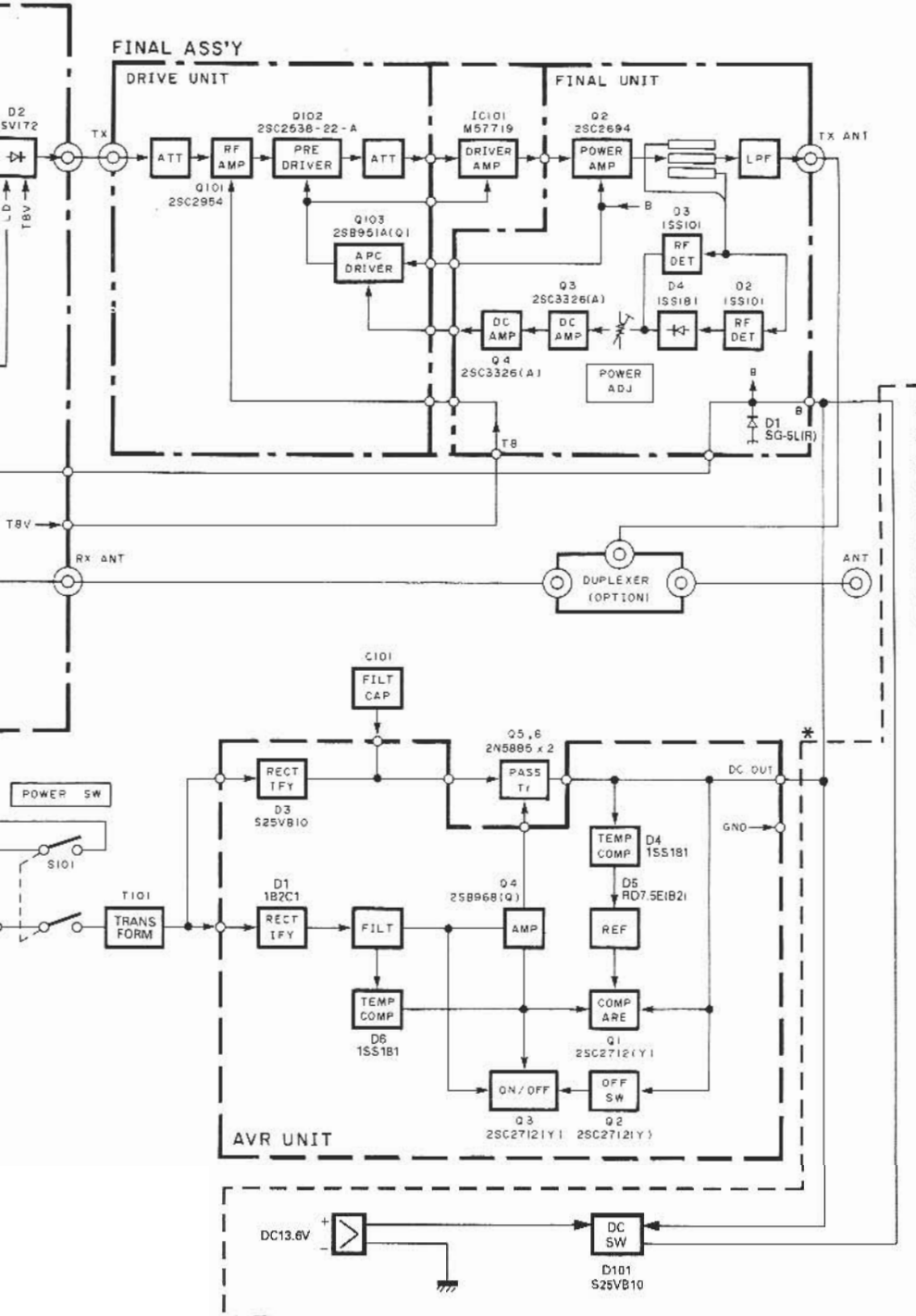

* [] TKR-720A only

TKR-720/N/A

CIRCUIT DESCRIPTION

Transmitter Circuit

The signal generated at the Transmitter Voltage Controlled Oscillator (TX VCO, Z5), which operates at the transmit frequency, is fed to a voltage amplifier Q101 (2SC2954) after going through a 3dB attenuator. The signal is further amplified by Q102 (2SC2538-22-A) and again fed through a 3dB attenuator before being applied to the driver module (IC101, M57719 or M57719L-24).

At IC101, the signal is power amplified and the output of IC101 is applied to the final power amplifier (Q2, 2SC2694). After power amplification at Q2, the signal is routed to the antenna connector after going through the antenna switching circuit and a 7-pole lowpass filter.

Q101 is biased for class B operation, which renders a low threshold, insuring a smooth operation from a very small signal level.

Q102 input circuit impedance is closely matched to the Q101 output impedance with low Q design in mind to obtain stable, board band operation. Incorporation of a low Q micro-strip line design permits transmitter operation without returning within its entire operating range.

Transmitter forward power is monitored at the Automatic Power Control (APC) detector (D3, 1SS101), located between the antenna switch and the lowpass filter, and this detector output is used for a comparison against the reference voltage at a differential amplifier (Q3 and Q4, 2SC3326A) after the level is set at VR1. The differential amplifier output drives the APC DC amplifier (Q103, 2SB951AQ), which in turn controls supply voltages to Q102 and IC101, to maintain constant output power.

To protect the transmitter power amplifier stages, there is a reflected power protection circuit.

The reflected power protection reduces the transmitter output power by controlling the differential amplifier, if a high VSWR condition is detected at the reflected power detector (D2, 1SS101).

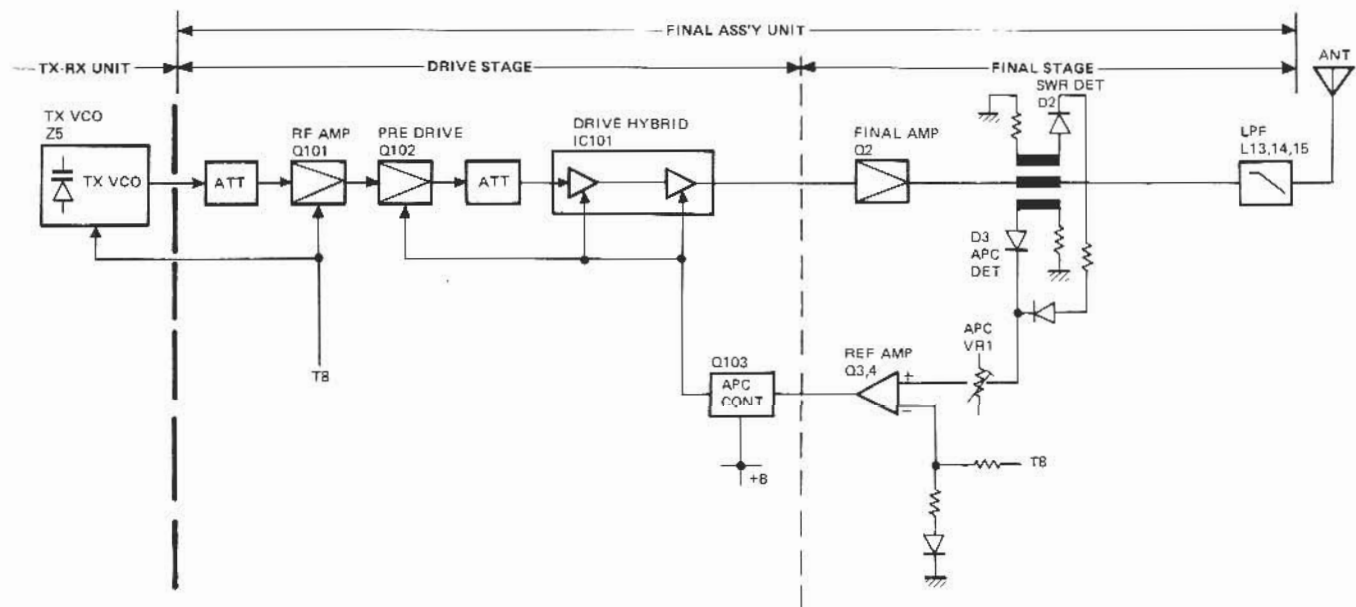

Fig. 1 Transmitter block diagram

CIRCUIT DESCRIPTION

Receiver Circuit

The surge voltage from the antenna is removed or absorbed by L27 and D12 (1SS226), and the receive signal is passed through the bandpass filter (L20, L21).

The signal is then amplified by an RF amplifier (Q14, 2SK125 and Q15, 2SK125 connected in parallel) and filtered again by bandpass filters (L24, L25 and L26). After amplification and filtering, the signal is applied to a double balanced modulator (DBM, D4, ND487C1T) for mixing with the first local signal generated at the common frequency synthesizer.

The heterodyning action of the first mixer produces a 21.4MHz first intermediate frequency (1st IF), which is applied to a 6-pole monolithic crystal filter (MCF, XF1) after being amplified by a buffer amplifier (Q4, 2SK125 and Q5, 2SK125 connected in parallel). The signal out of the MCF is further amplified by a 1st IF amplifier (Q6, 2SK302GR) and sent to the IF unit (Z8).

The signal applied to Z8 is mixed with a 20.945MHz signal at IC1 in Z8, which produces a 455kHz 2nd IF signal. The signal obtained at the 2nd mixer is filtered by a 455kHz ceramic filter (CF1) and amplified by limiting amplifier stages in IC1. The recovered audio signal from the incoming signal is also obtained at IC1 by a quadrature type FM detector. This recovered audio signal is then sent to the audio amplifier circuit and to the noise actuated squelch circuit.

In the receiver audio amplifier section, the recovered audio signal from Z8 is first applied to a bandpass filter/voltage controlled amplifier (BPF/VCA, Z9) unit. At this BPF/VCA unit, the signal is amplified and sent to pin 9 of CN6 as the DET signal. The signal is returned to Z9 by way of the Signaling unit. IC1 (NJM4558M) forms a lowpass filter and a highpass filter, and IC2 forms a bandpass filter and lowpass filter in Z9. The frequency components below 300Hz and above 3000Hz are attenuated in the above filter circuits.

The filtered audio signal is then applied to an electronic volume control (IC3, M5222FP), where the audio signal level is controlled by a DC voltage sent from the front panel volume control. The signal is then de-emphasized and sent to the audio power amplifier circuit (IC1, μ PC1242H) after going through squelch switches (Q9 and Q10, 2SC3326A).

The alert signal is also applied to IC1, when a specific signaling board, which requires an audible alert through the speaker, is installed. The signal, which is amplified by IC1, drives either the internal speaker or the optional external speaker and this selection is done through the accessory connector located on the Final unit.

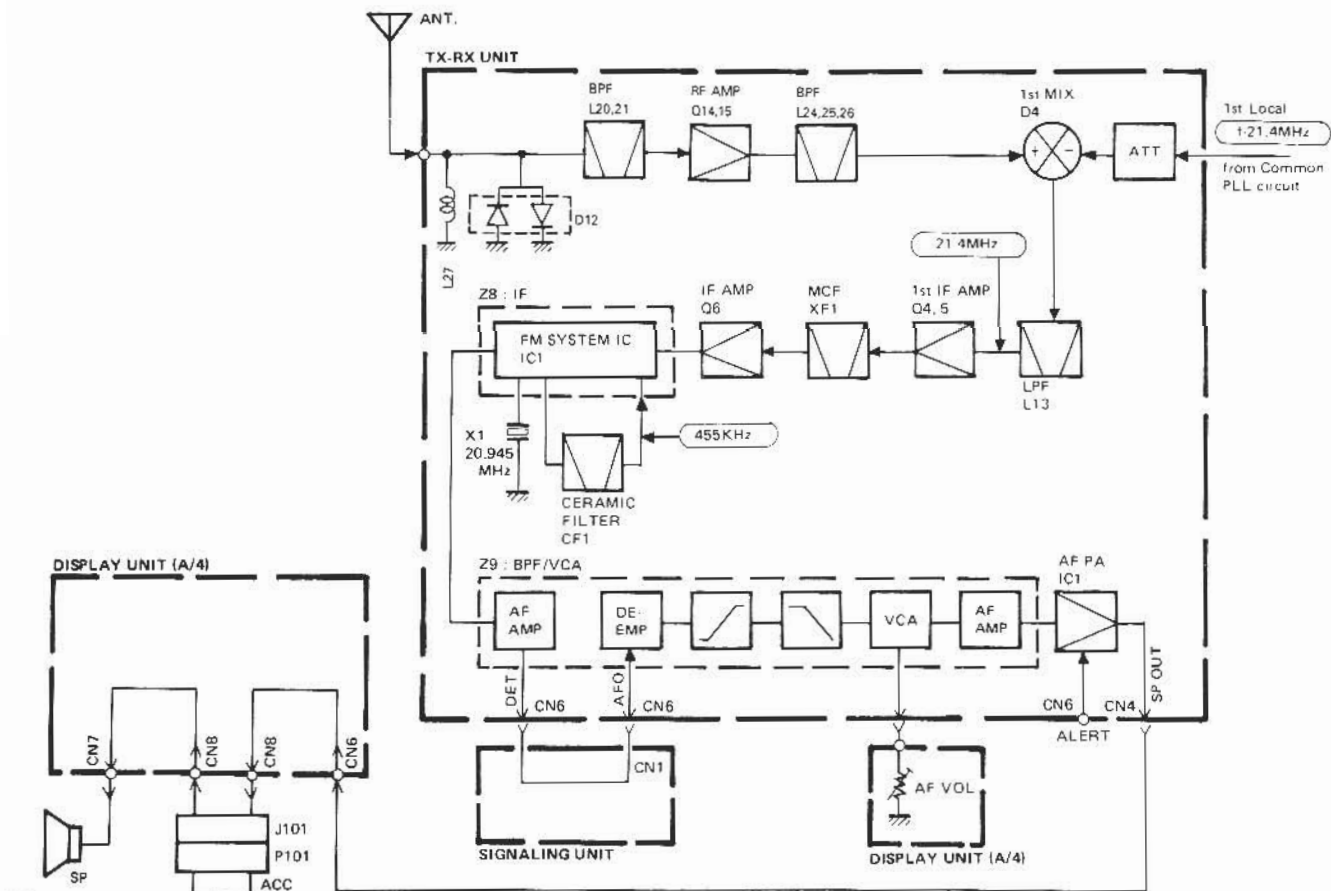

Fig. 2 Receiver block diagram

CIRCUIT DESCRIPTION

Squelch Circuit

The high frequency component of the recovered audio signal is fed to a noise amplifier within IC1 (MC3361BD) of Z8 and it is further amplified by an external noise amplifier (Q1, 2SC2712Y). The signal is then detected by a noise detector (D1, DA204K) and applied to the squelch switch in IC1. This detected noise is also routed to the squelch control (VR1) through the Display unit (C/4) for adjusting the noise squelch sensitivity.

The busy information is sent from the above IC1 (75104G-604-1B) in the Display unit in serial format to turn on or off the busy LED. The squelch switch output and the Audio Control (AC) signal from the signaling board are combined at D8 (1SS184) and applied to

squelch switch transistors Q9 (2SC3326A) and Q10 (2SC 3326A) along with the inverted signal of transmit/receive control signal. The squelch switch controls the input signal to the audio amplifier to mute or unmute the receive audio.

While the busy LED is being controlled only by the noise squelch circuit, the actual audio signal is controlled by the following signals and in order to unmute the audio, each signal must be in the condition as specified.

- SQL signal = Low
- R8 line = High
- T/R signal = High
- AC signal = Low

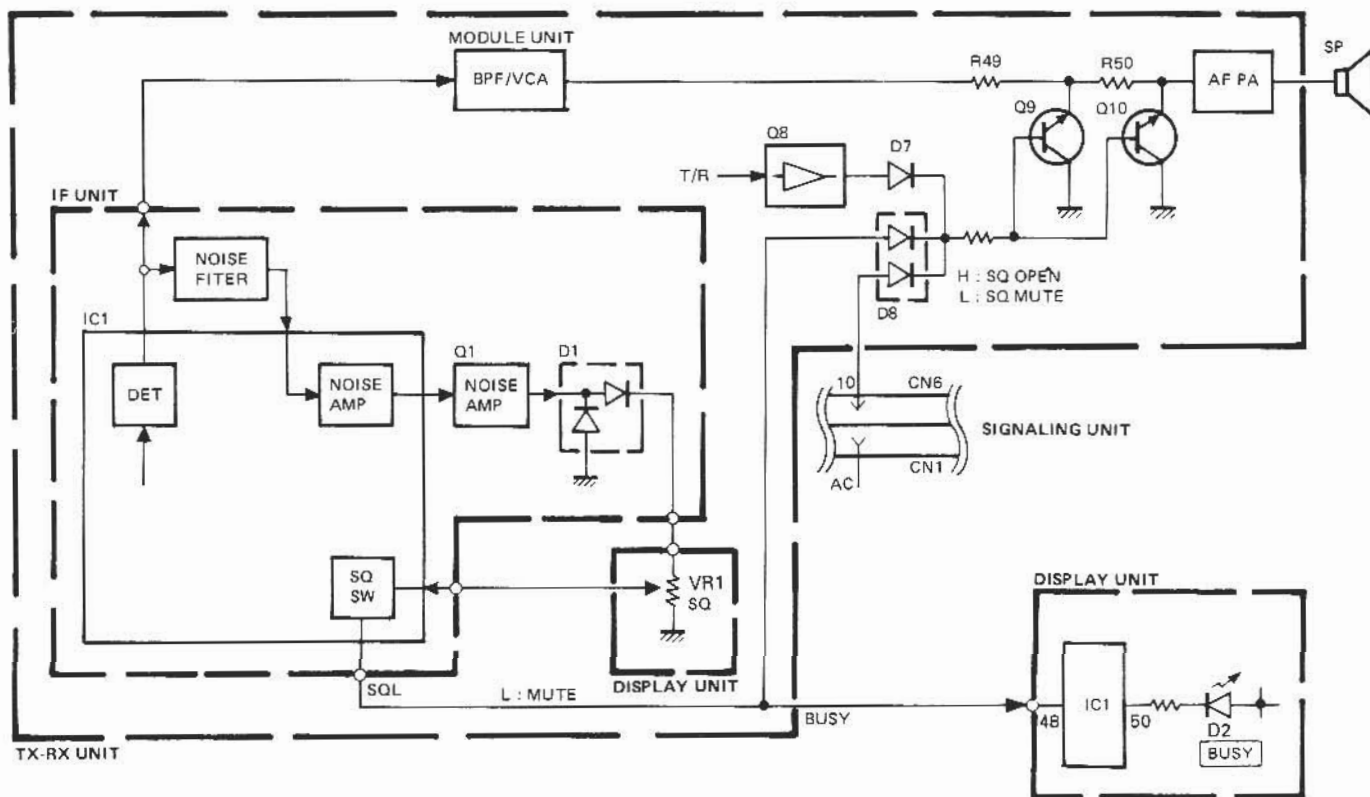

Fig. 3 Squelch circuit

CIRCUIT DESCRIPTION

RX Frequency Synthesizer

The RX frequency synthesizer consists of three major circuits. They are the temperature compensated crystal oscillator (TCXO, Z3), RX voltage controlled oscillator (RX VCO, Z2) and RX phase locked loop unit (RX PLL, Z1).

The TCXO is operating at 12.8MHz and its frequency stability is maintained within ± 2.5 ppm from -30°C to $+60^{\circ}\text{C}$. This output signal is fed to the frequency synthesizer IC (IC2, JLC1075F) in Z1. At IC2, this signal is divided by 2560 to become a 5kHz reference signal.

The output from the RX VCO operates at the frequency of the receiver first local signal and a portion of the signal is fed to a dual modulus counter formed by IC1 (MB504F) and IC2 in Z1. IC1 divides the incoming signal by 1/64 or 1/65 depending on the control line status sent from IC2. The output of the dual modulus counter is also a 12.5kHz and this signal is compared against the 12.5kHz reference signal in a phase comparator at IC2. The output signal from the phase comparator is then fed back to the RX VCO after going through a charge pump and a lowpass filter to maintain the RX VCO frequency.

If this RX frequency synthesizer phase locked loop becomes UNLOCK, the unlock condition is detected by IC2 and it prevents the transmitter frequency synthesizer from sending a transmitter signal to following amplifier stages in order to prevent an unauthorized transmission.

TX Frequency Synthesizer

The TX frequency synthesizer consists of three major circuits. They are the modulator/voltage controlled crystal oscillator (VCXO, Z6), TX voltage controlled oscillator (TX VCO, Z5) and TX phase locked loop unit (TX PLL, Z4).

The audio signal from the microphone amplifier and the Signaling unit is applied to the TX VCO (Z5) and the VCXO (Z6) operating at 12.8MHz to obtain an FM modulated signal. And its frequency stability is maintained within ± 2.5 ppm from -30°C to $+60^{\circ}\text{C}$. This output signal is fed to the frequency synthesizer IC (IC2, JLC1075F) in Z4. At IC2, this signal is divided by 2560 to become a 5kHz reference signal.

The output from the TX VCO operates at the frequency of the transmit signal and a portion of the signal is fed to a dual modulus counter formed by IC1 and IC2 in Z4. IC1 divides the incoming signal by 1/64 and 1/65 depending on the control line status sent from IC2. The output of the dual modulus counter is also a 12.5kHz and this signal is compared against the 12.5kHz reference signal in a phase comparator at IC2. The output signal from the phase comparator is then fed back to the TX VCO after going through a charge pump and a lowpass filter to maintain the TX VCO frequency.

If this TX frequency synthesizer phase locked loop becomes UNLOCK, the unlock condition is detected by IC2 and it prevents the transmitter frequency synthesizer from sending a transmitter.

Microphone Amplifier

The audio signal originating at the microphone is applied to a microphone amplifier unit (Z7) after going through a microphone sensitivity control (VR1).

The signal is amplified and voltage limited by IC1 and IC2 in Z7, then applied to an active lowpass filter/pre-emphasis network (IC3).

The processed audio signal is sent to the modulator/voltage controlled crystal oscillator (VCXO, Z6) and voltage controlled oscillator (TX VCO, Z5) in the transmitter frequency synthesizer via IC3.

CIRCUIT DESCRIPTION

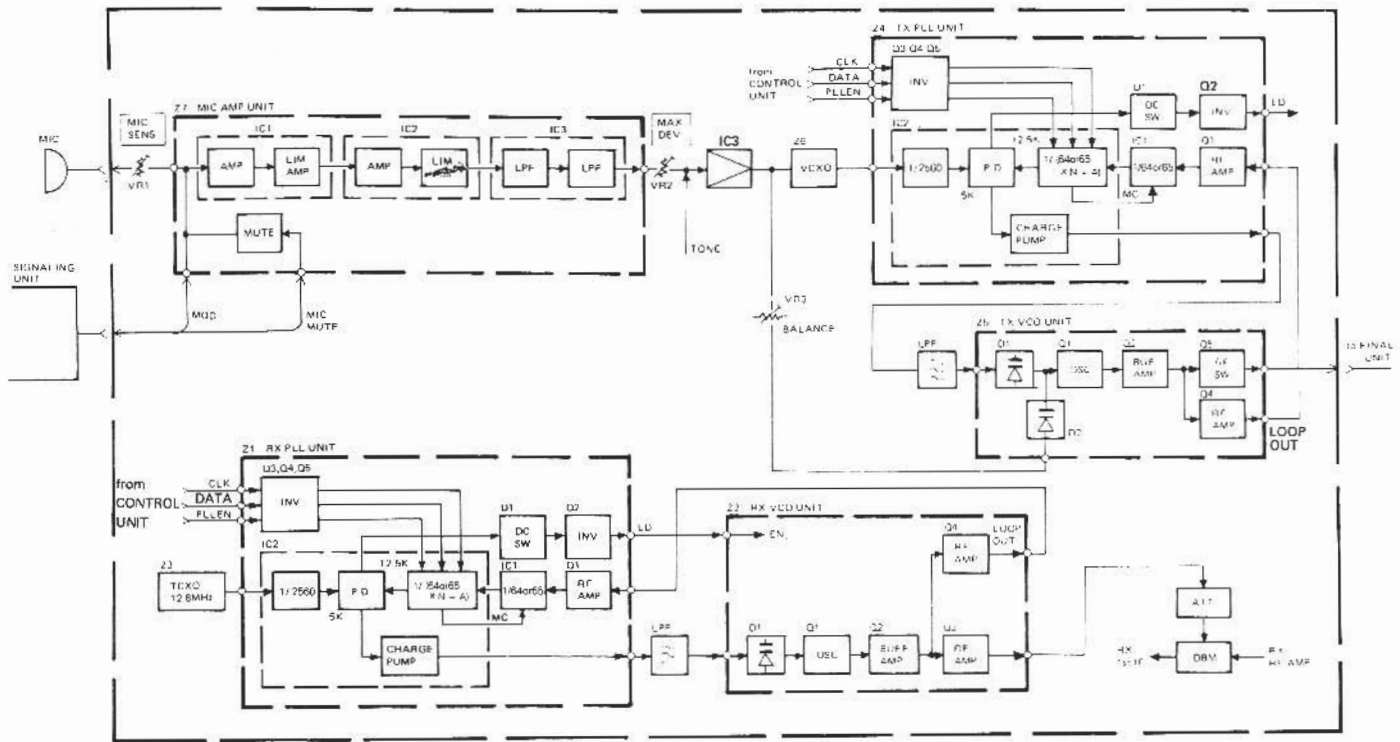

Fig. 4 PLL & Modulation circuit block diagram

Reset Circuit

Upon initial power up, the line voltage gradually increases and this causes the reset system (IC3) to generate a reset pulse. This reset pulse is applied to the microprocessor (IC1) to insure the initialization of the circuit.

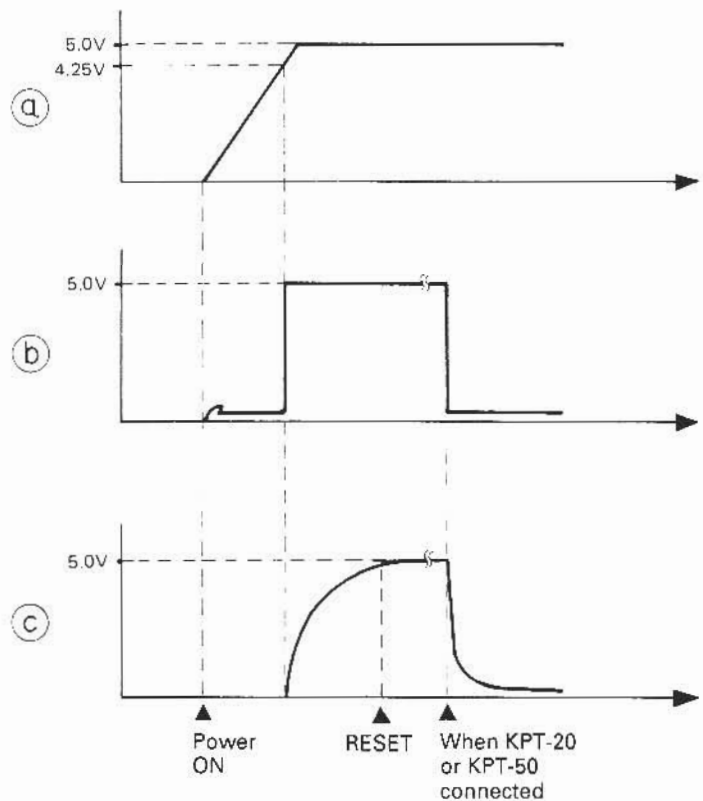
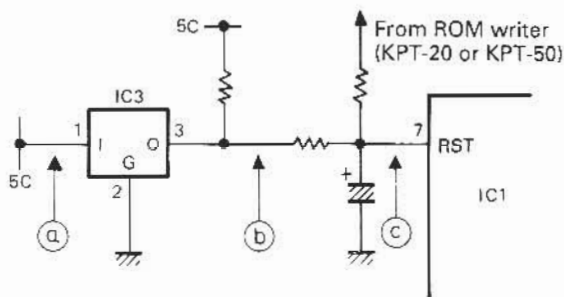

Fig. 5 Reset circuit block diagram

CIRCUIT DESCRIPTION

EEPROM Programming

Programming of data into the EEPROM (IC2) in the Display unit is done by connecting the KPT-20 or KPT-50 programmer to the transceiver by cable provided with the KPT-20 or KPT-50. When the programmer is connected to CN1 in the Display unit, this causes microprocessor IC1 to go into reset condition. In the reset condition, the output ports of IC1 becomes high impedance and are isolated from the data transfer lines. This permits data transfers between the programmer and the EEPROM.

Signaling Unit

• Decoder operation

The receive audio signal from the receiver section is fed to the Signaling unit. A part of this signal is returned to the receive audio amplifier circuit and fed to mute circuit after going through an active high-pass filter, in which any frequencies below 300Hz are removed. The mute circuit control a transfer audio signal by microprocessor. The other part of the audio signal is fed through a fifth-order active low-pass filter, of which the cut-off frequency is set at 220Hz, to discriminate the QT and DQT signals from other audio signals.

The QT tone obtained from the above filtered audio signal is applied to the microprocessor (IC11) as an analog signal for tone detection after being amplified by IC4 (2/2).

The DQT code is passed through a low-pass filter IC3 (2/2), of which the cut-off frequency is 140Hz, and the circuit consists of IC3 (1/2) and IC5 (1/2), where the DC drift component (low frequency) is removed from the signal. The signal is then amplified by IC5 (2/2). The amplified signal is applied to IC1 after waveform shaping by Q2.

IC11 sends an audio control signal (AC) to the AC terminal of CN1 through an inverter (Q4) according to the status of the incoming signal. If the incoming QT tone or DQT code matches the data stored, the AC terminal of CN1 is forced to become "LOW" to unmute the receive audio circuit.

• Monitor circuit

The RESET terminal of CN1 is connected to the MONITOR and MIC MONITOR circuits in the repeater.

The RESET terminal signal level goes to "HIGH" state, if either the MONITOR switch is on or the microphones MONITOR switch is on, causing pin 4 (RESET) of IC11 to become "HIGH". In this condition, the AC terminal of CN1 is held "LOW", enabling only the noise actuated squelch operation.

• Encoder operation

In the transmit mode, the PTT terminal of CN1 becomes "LOW" and this information is inverted to "HIGH" by Q7 before being applied to IC11. Upon receipt of this PTT signal or when the programmed tone has been decoded at the time of the REPEAT operation, IC11 starts the encode function. The encode signal is sent out from output ports, A/D 0 through A/D 7, of IC11 in a binary format and is fed to a ladder network resistor (CP1) for Digital-to-Analog signal conversion. The output signal from CP1, which is either the QT tone or the DQT code, is routed to the TONE terminal of CN1 after going through a level control for modulating the transmit signal.

• Local/Repeater operation

When the REPEAT switch on the front panel of the main body is set to ON, the repeater operation is engaged, while when this switch is set to OFF, the full-duplex transceiver operation is engaged.

• Preset squelch operation

The squelch circuit for the repeater operation which is independent from the main body consists of noise conditioner IC6 (1/2), waveform shaper Q1, microprocessor IC11 and squelch sensitivity adjuster VR1.

The preset squelch level, the hangup timer time and the time-out timer time are compared in IC11 respectively with the voltages at pins 30, 29 and 28 set by VR1, VR2 and VR3 with the reference of the voltage at pin 31 of IC11 and are thus subject to software control.

CIRCUIT DESCRIPTION

TAKEOVER Switch

The TAKEOVER switch is used to isolate the remote control. (The remote control is isolated when the TAKEOVER switch is pressed.)

The following table shows the functions and specifications of the accessory connector terminals, together with the control terminals that are subject to the TAKEOVER control.

• **Accessory connector (J101)**

No.	Name	Functions & Specifications	Terminal subject to TAKEOVER control
1	HK	External hook terminal / Set this terminal to GND level before using external PTT. Unlike MIC HOOK, no monitor function is provided. (TKR-720/N only)	○
2	LG	Line input GND / Used for No. 5 (LI).	
3	DI	Direct modulation input terminal / External input terminal for QT and DQT : $\pm 750\text{Hz DEV}$ at approx. 600Ω input impedance, 0.2Vp-p . Degree of modulation is to be adjusted externally.	
4	DO	Direct detection output / Direct output of detected (unfiltered) signal : Output impedance $10\text{k}\Omega$. Output level : -10dBs at $\pm 3\text{kHz DEV}$, 1kHz .	
5	LI	Line input / Input terminal for external modulation. Standard modulation is provided at 600Ω , 0.24dBm . Same as MIKE level except for input level.	○
6	SG	Speaker output GND / GND for output to external speaker. Used for No. 12 (SO).	
7	SB	+13.6V external power output / Power supply for external equipment. Up to 1A.	
8	PT	External PTT input / Transmission is started at GND level if No. 1 (HK) is at GND level.	○
9	SI	Internal speaker input / Usually connected to No. 12 (SO) via jumper wire.	
10	LO	Line output / Used for output of received signal, for standard modulation at 600Ω , -10dBm , -6dB/oct , 300Hz to 3kHz . Interlocked with No.13 (CO).	○
11	GN	DC GND / GND for DC power supply.	
12	SO	Speaker output / Output terminal for external speaker.	
13	CO	Internal preset squelch output / Provides an output interlocked with internal preset squelch, or a tone squelch output when writing tone. When receiving signal, this output is at low level (open collector) with 10mA sink current.	
14	NC	Unused.	
15	NC	Unused.	

CIRCUIT DESCRIPTION

AVR Circuit

This power supply uses a tapped secondary transformer to maintain low voltage between the pass transistor collectors and emitters (Q5 and Q6) for excellent efficiency. Control and operating voltages are rectified and supplied independently for good ripple characteristics.

Temperature compensation for the regulator Zener diode D5 and error amplifier transistor Q4 is provided by silicon diodes D4 and D6.

At initial POWER-ON Q3 is ON to turn-down Q4 base voltage. This prevents a surge voltage from being output when no load is connected. As C5 charges, Q2 turns ON to shut Q3 OFF. Q4 is thereafter fully ON.

If the load is shorted, comparator Q1 is turned OFF and current proportional only to that in the initial turn-on circuit is output. When the output is shorted, the output current drops to 1A. This circuit protects the pass transistors, transformer and full wave bridge rectifies from thermal damage.

Changing between AC and DC is done with the DC switch (D101) for the TKR-720A only. The output from the AVR unit and the DC input from the external power input terminals are changed automatically.

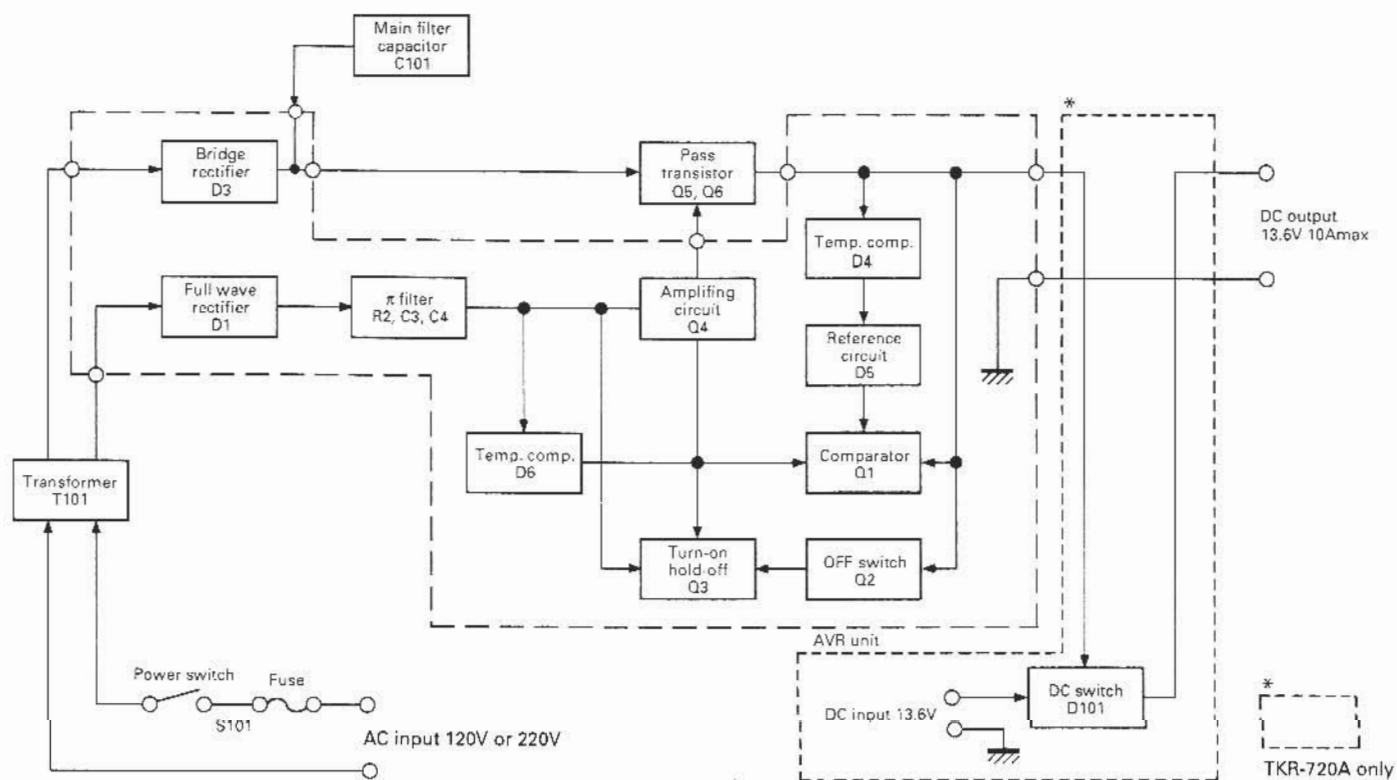
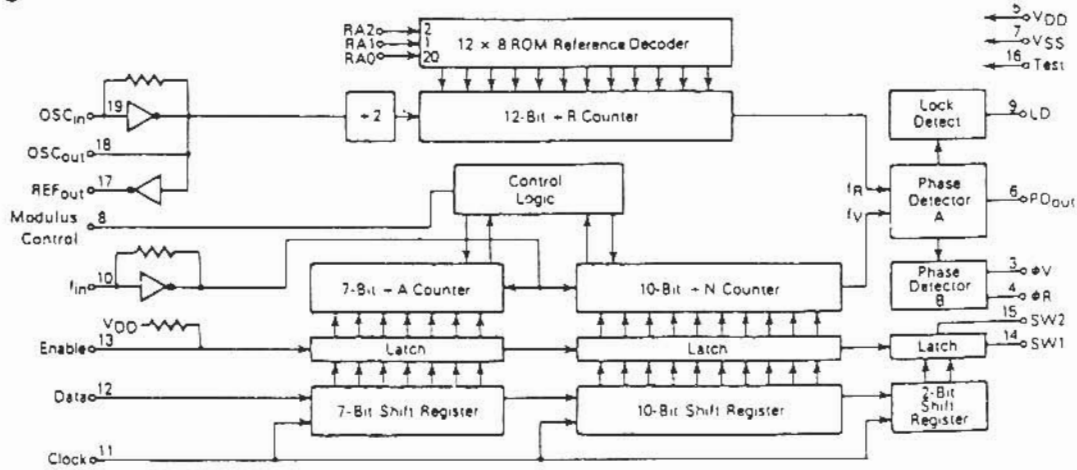

Fig. 6 AVR circuit block diagram

SEMICONDUCTOR DATA

JLC1075F : PLL system (TX PLL, RX PLL IC2)

• Block diagram



Reference Address Code			Total Divide Value
RA2	RA1	RA0	
0	0	0	8
0	0	1	64
0	1	0	128
0	1	1	256
1	0	0	1160
1	0	1	2560
1	1	0	1024
1	1	1	2048

• Terminal connection diagram

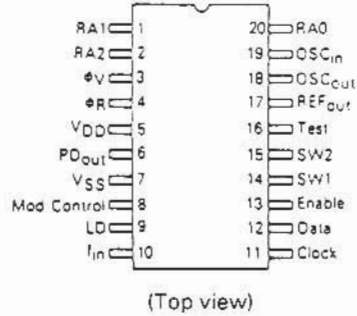

M51943BML : Reset system (Signaling unit IC2), Precision reference (Display unit IC3)

• Terminal connection diagram

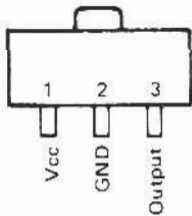

• Block diagram

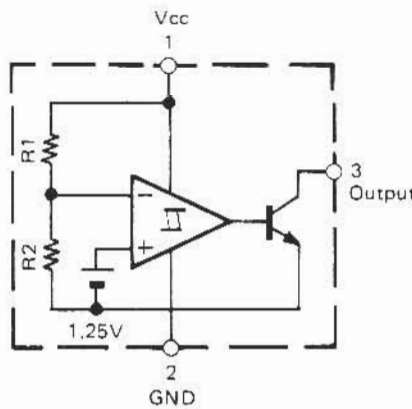

• Timing chart

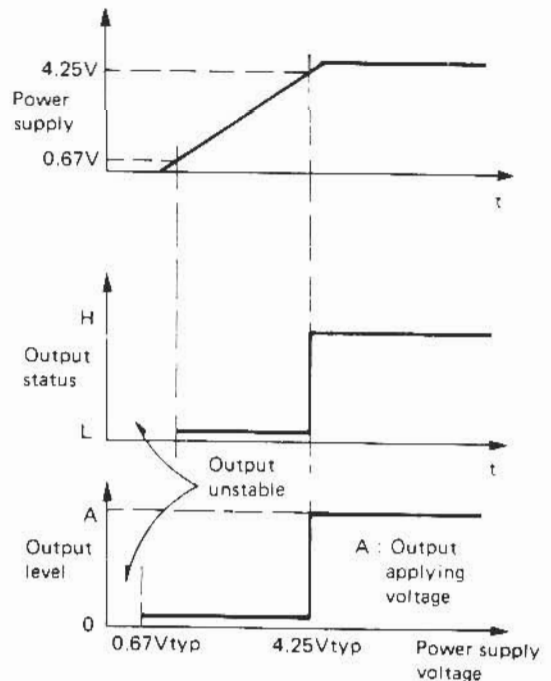

SEMICONDUCTOR DATA

M5222FP : Electronic attenuator (BPF/VCA IC3)

• Terminal connection diagram

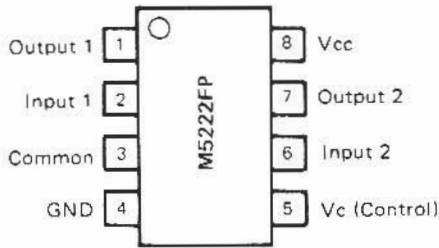

• Equivalent circuit

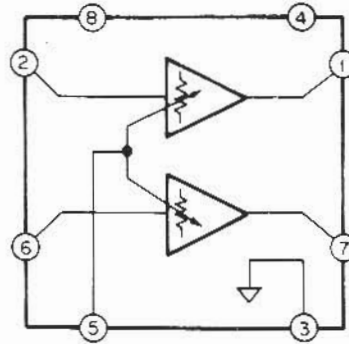

M57719, M57719L-24 : RF amplifier, TX driver (Final unit ass'y IC101)

• Terminal connection diagram

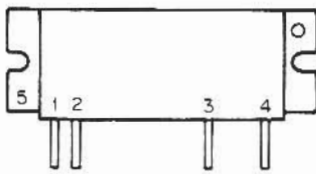

- 1 : Input
- 2 : Pre-drive + B
- 3 : Bias + B
- 4 : Final + B
- 5 : Output
- 6 : GND

• Block diagram (M57719)

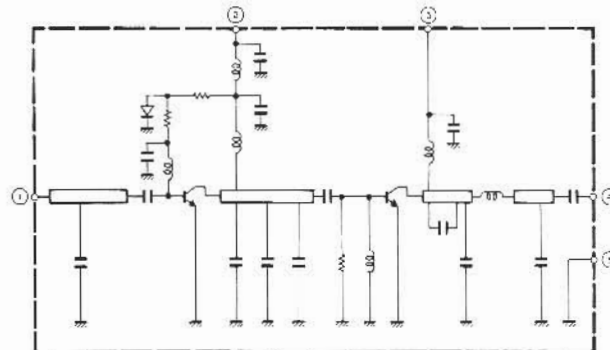

• Block diagram (M57719L-24)

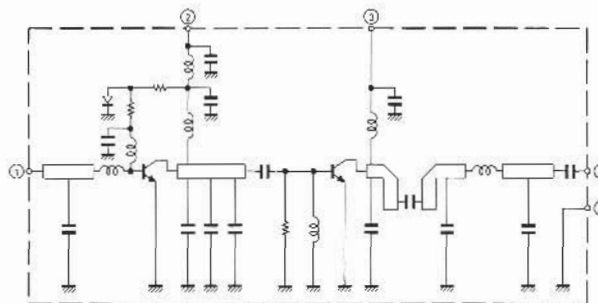

• Electrical characteristics

Symbol	Item	Condition	Rating (M57719)			Rating (M57719L-24)			Unit
			Min.	Typ.	Max.	Min.	Typ.	Max.	
PO	Output power	f = 145~174MHz (M57719)	14	16		14	16		W
η_T	Total efficiency	f = 136~150MHz (M57719L-24)	40	45		40	45		%
	2nd spurious	Vcc = 12.5V			-25			-25	dB
	Spurious after 3rd.	Pin = 0.2W			-35			-35	dB
p in	Input SWR	Zg = ZL = 50 Ω			4			4	-
p out	Output SWR			1.8			2		-

SEMICONDUCTOR DATA

MB504F : Prescaler (TX PLL, RX PLL IC1)

• Terminal connection diagram

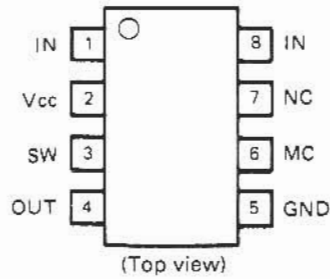

• Function table

SW	MC	Divide value
H	H	32
H	L	33
L	H	64
L	L	65

Note : SW terminal
 H : Vcc, L : Open
 MC terminal
 H : 2.0V~Vcc, L : GND~0.8V

• Explanation of terminal functions

Pin No.	Symbol	Function
1	IN	Input.
2	Vcc	Power supply.
3	SW	Dividing ratio select pin.
4	OUT	Output.
5	GND	Ground.
6	MC	Module set pin.
7	NC	Not connection.
8	IN	Compensated input.

MB3756 : Voltage regulator (TX-RX unit IC2)

• Electrical characteristics

Item	Symbol	Condition	Rating			Unit
			Min.	Typ.	Max.	
Input voltage range	V _{IN}		10.6	-	18	V
Output voltage	V _O		7.8	8.2	8.6	V
Input stability		11V ≤ V _{IN} ≤ 18V	-	20	100	mV
Load stability		(V _{O1} , V _{O1}) 1mA ≤ I _L ≤ 100mA	-	15	80	mV
		(V _{O2}) 1mA ≤ I _L ≤ 200mA	-	20	100	mV
Voltage difference between outputs	ΔV _O		-	10	50	mV
Peak output load	I _{sc}	(V _{O1} , V _{O1})	-	200	-	mA
		(V _{O2})	-	350	-	mA
Output voltage short-circuit current (Active 'L')	V _{O1} (L)	V _{ic} = 0.8V	0	-	0.2	V
	V _{O2} (L)	V _{ic} = 0.8V	7.8	8.2	8.6	V
Output voltage short-circuit current (Active 'H')	V _{O1} (H)	V _{ic} = 2.0V	7.8	8.2	8.6	V
	V _{O2} (H)	V _{ic} = 2.0V	0	-	0.2	V

(T_J = 25°C, V_{IN} = 14, R_{L0} = R_{L1} = 200Ω, R_{L2} = 100Ω)

• Terminal connection diagram

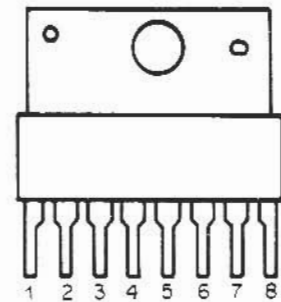

• Equivalent circuit

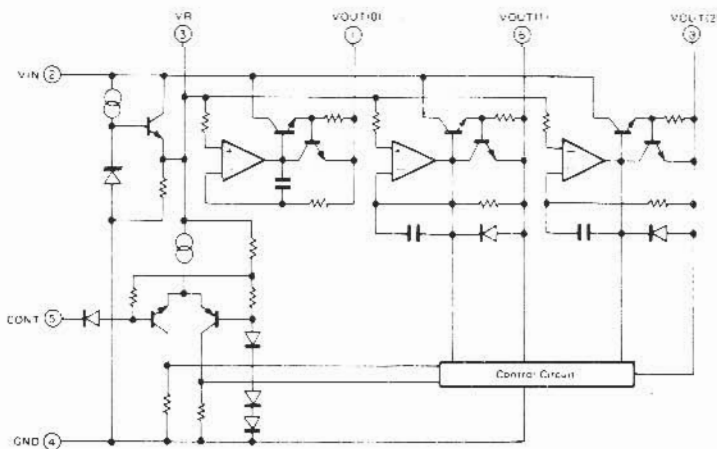

MC3361BD : IF system (IF IC1)

• Block diagram

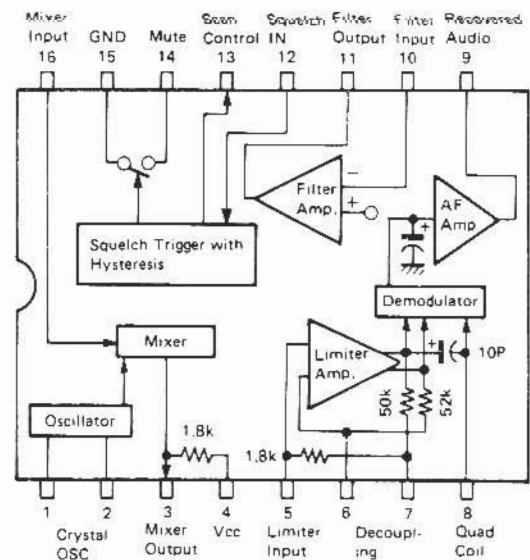

SEMICONDUCTOR DATA

XLJ93LC46 : EEPROM (Signaling unit IC10, Display unit IC2)

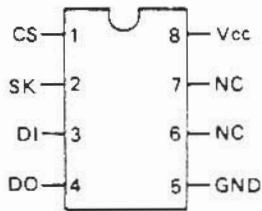

(Top view)

- CS : Chip Select
- SK : Serial Data Clock
- DI : Serial Data Input
- DO : Serial Data Output
- Vcc : Power Supply
- GND : Ground
- NC : Not Connected

• Instruction set for XLJ93LC46

Instruction	SB	Op code	Address	Data	Comments
READ	1	10	A5A4A3A2A1A0		Read Register A5A4A3A2A1A0
WRITE	1	01	A5A4A3A2A1A0	D15~D0	Write Register A5A4A3A2A1A0
ERASE	1	11	A5A4A3A2A1A0		Erase Register A5A4A3A2A1A0
EWEN	1	00	11XXXX		Erase/Write Enable
EWDS	1	00	00XXXX		Erase/Write Disable
ERAL	1	00	10XXXX		Erase All Registers

XLJ93LC46 has 6 instructions as shown. Note that the MSB of any given instruction is a "1" and is viewed as a start bit in the interface sequence. The next 8 bits carry the op code and the 6-bit address for 1 of 64, 16-bit registers.

• Timing chart (Continued)

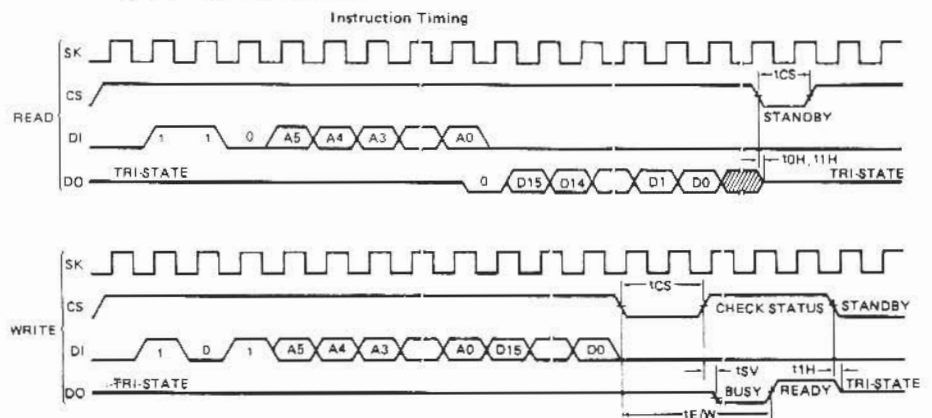

μPC1242H : AF power amplifier (TX-RX unit IC1)

• Block diagram

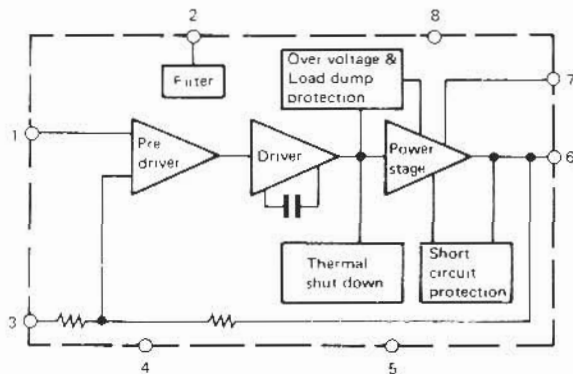

- 1 : Input
- 2 : Ripple filter
- 3 : N.F.B.
- 4 : GND
- 5 : GND
- 6 : Output
- 7 : Bootstrap
- 8 : Vcc

• Electrical characteristics

Item	Symbol	Condition	Rating			Unit
			Min.	Typ.	Max.	
DC current	I _{CC}	v _{in} = 0	25	45	80	mA
Output power	P _O	T.H.D = 10%	5.0	5.8		W
		R _L = 2Ω, T.H.D = 10%		9.2		W
Distortion	T.H.D.	P _O = 0.5W		0.1	1.0	%
		R _L = 2Ω, P _O = 1W		0.4		%
Max. output power	P _{OM}			9.5		W
Voltage gain	A _v	P _O = 0.5W	49	51.5	54	dB
Noise output voltage	v _n	R _G = 10kΩ		1.4	4	mV _{rms}

(T_a = 25°C, V_{CC} = 13.2V, f = 1kHz, R_L = 4Ω)

SEMICONDUCTOR DATA

μPD78310AGF : Microprocessor (Signaling unit IC11)

• Terminal connection diagram

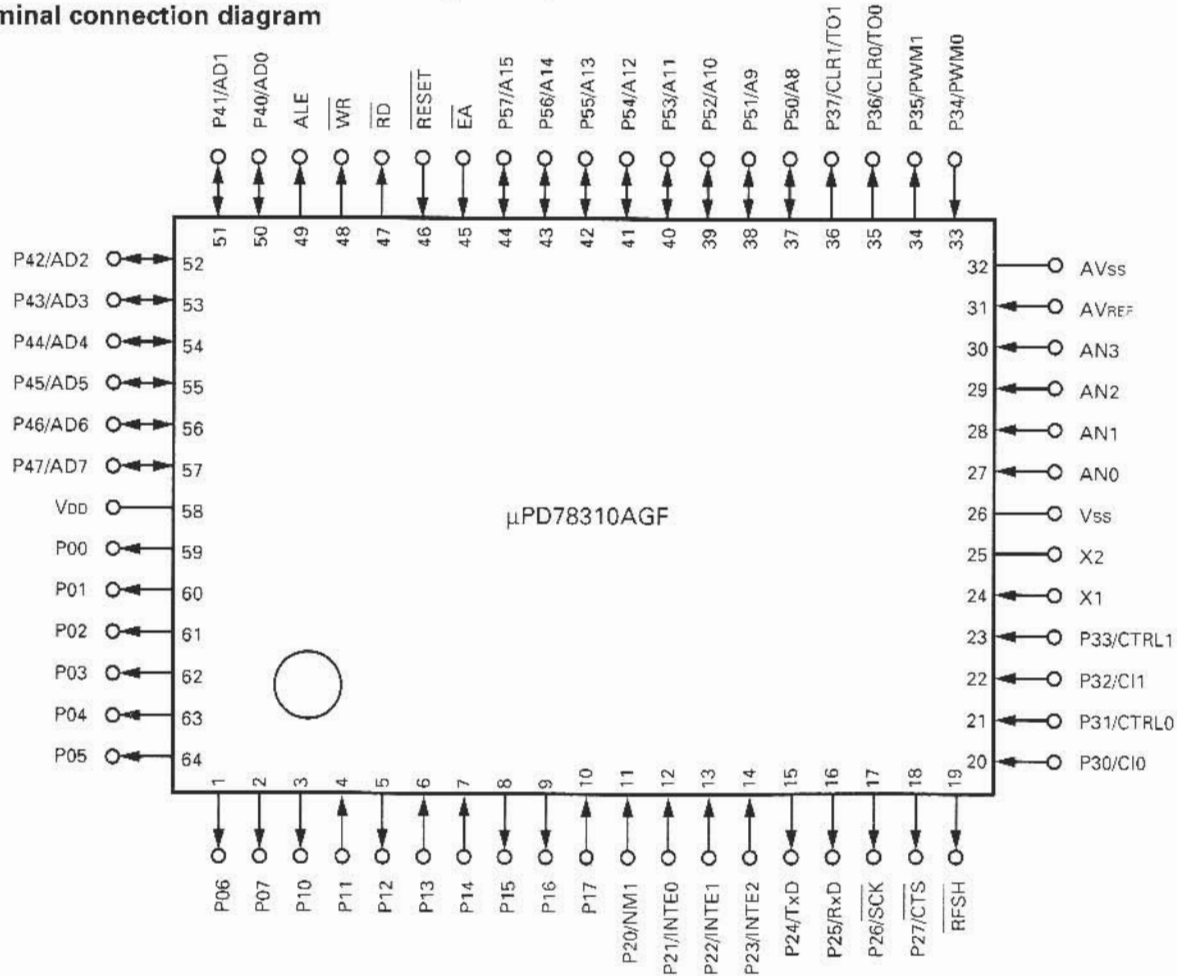

• Explanation of terminal functions

No.	Port	I/O	Signal name	No.	Port	I/O	Signal name
1, 2	P06, P07	O	A/D6, A/D7 (R-2R)	24, 25	X1, X2	-	X'tal
3	P10	O	Key	26	Vss	-	GND
4	P11	I	Reset	27	AN0	I	CTCSS IN
5	P12	O	AC	28	AN1	I	TOT VR
6	P13	I	LOC/REP	29	AN2	I	HUNG UP TIMER VR
7	P14	I	PTT	30	AN3	I	P-SQ VR
8	P15	O	TOR	31	AVREF	-	+5V
9	P16	O	TONE DET	32	AVss	-	GND
10	P17	I	DQT	33	P34/PWM0	I	DO (EEPROM)
11	P20/NM1	I	Check	34	P35/PWM1	O	DI (EEPROM)
12	P21/INTE0	I	CH CLK	35	P36/CLR0/TO0	O	CLK (EEPROM)
13	P22/INTE1	I	CH DATA	36	P37/CLR1/TO1	O	CS (EEPROM)
14	P23/INTE2	I	CH EN	37~44	P50/A8~P57/A15	CONT.	A8~A15 (EPROM)
15	P24/TxD	O	Not use.	45	EA	CONT.	External access
16	P25/RxD	O	Mute	46	RESET	CONT.	Power on reset
17	P26/SCK	O	COR	47	RD	CONT.	READ (EPROM)
18	P27/CTS	O	Test	48	WR	CONT.	WRITE (EPROM)
19	RFSH	CONT.	Refresh	49	ALE	CONT.	Address latch enable
20	P30/CI0	I	P-SQ	50~57	P40/AD0~P47/AD7	CONT.	AD0~AD7 (EPROM)
21	P31/CTRL0	I	W2	58	VDD	-	+5V
22	P32/CI1	I	W1	59~64	P00~P05	O	A/D0~A/D5 (R-2R)
23	P33/CTRL1	I	W4				

SEMICONDUCTOR DATA

• Block diagram

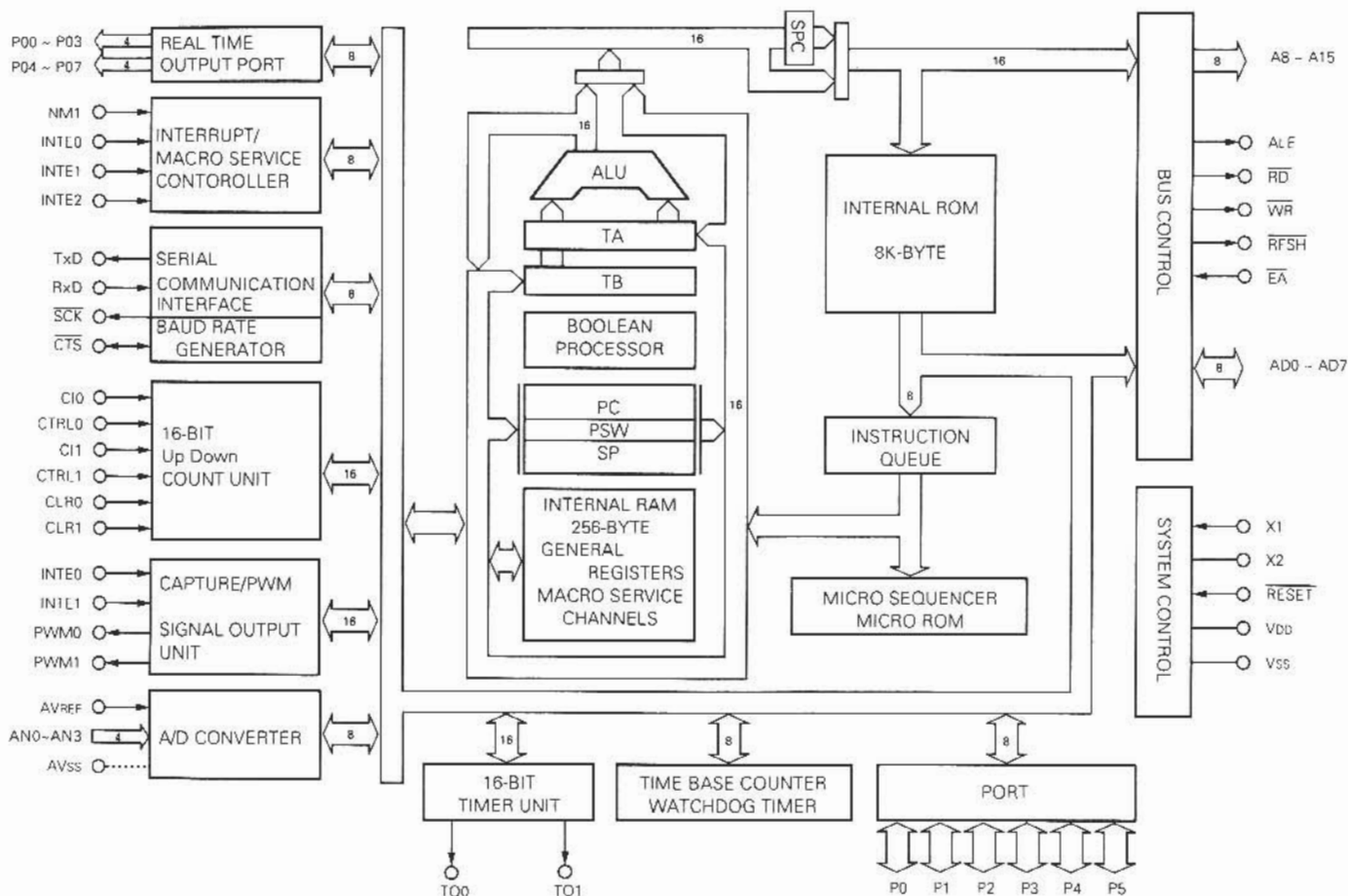

2SC2694 : Power amplifier (Final unit Q2)

• Terminal connection diagram

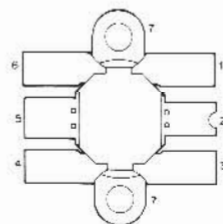

- 1 : Emitter
- 2 : Collector
- 3 : Emitter
- 4 : Emitter
- 5 : Base
- 6 : Emitter
- 7 : Flange

• Electrical characteristics

(Tc = 25°C)

Item	Symbol	Condition	Rating			Unit
			MIN.	TYP.	MAX.	
Collector - base breakdown voltage	V _{BRICBO}	I _c = 20mA, I _E = 0	35			V
Emitter - base breakdown voltage	V _{BRIEBO}	I _E = 20mA, I _c = 0	4			V
Collector - emitter breakdown voltage	V _{BRICEO}	I _c = 0.1A, R _{BE} = ∞	17			V
Collector cut-off current	I _{CBO}	V _{CB} = 15V, I _E = 0			5	mA
Emitter cut-off current	I _{EBO}	V _{EB} = 3V, I _c = 0			5	mA
DC current amplification factor	h _{FE}	V _{CE} = 10V, I _c = 1A	10	50	180	-
Output power	P _o	f = 175MHz, V _{CC} = 12.5V,	70	75		W
Collector efficiency	η _C	P _{in} = 15W	60	70		%

SEMICONDUCTOR DATA

75104G-604-1B : Microprocessor (Display unit IC1)

• Terminal connection diagram

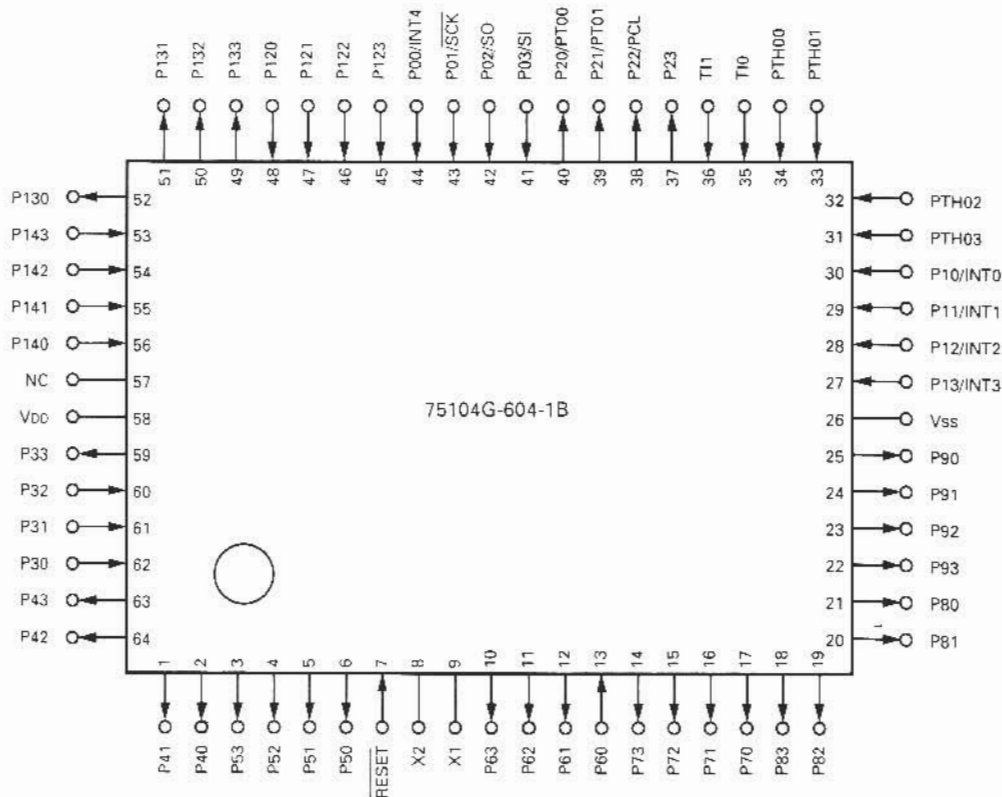

• Explanation of terminal functions

No.	Port	I/O	Signal name	No.	Port	I/O	Signal name
1, 2	P41, P40	O	LED (D23) b, a segment. (Active 'H') TKR-720A only	37	P23	O	TX PLL EN. (Active 'H')
3	P53	O	GND. (Active 'L')	38	P22/PCL	O	T/R. (Active 'L')
4~6	P52~P50	O	LED (D23) g~e segment. (Active 'H') TKR-720A only	39	P21/PT1	O	PTT. (Active 'L').
7	RESET	I	System reset input.	40	P20/PT0	-	No connection.
8, 9	X2, X1	-	Crystal.	41	P03/SI	I	PTT (Remote).
10	P63	O	CS (EEPROM). (Active 'L')	42	P02/SO	I	MON (Remote).
11	P62	O	CLK (EEPROM). (Active 'L')	43	P01/SCK	I	GND.
12	P61	O	DI (EEPROM). (Active 'L')	44	P00/INT4	I	TAKEOVER switch.
13	P60	I	DO (EEPROM).	45	P123	I	MONI switch.
14	P73	O	CH CLK. (Active 'L')	46	P122	I	REPEAT switch.
15	P72	O	CH DATA. (Active 'L')	47	P121	I	KEY.
16	P71	O	PLL EN. (Active 'H')	48	P120	I	BUSY.
17	P70	O	CH EN. (Active 'L')	49	P133	O	TX LED. (Active 'H')
18~21	P83~P80	O	LED (D22) d~a segment. (Active 'H') TKR-720A only	50	P132	O	BUSY LED. (Active 'H')
22	P93	O	GND. (Active 'L')	51	P131	-	No connection.
23~25	P92~P90	O	LED (D22) g~e segment. (Active 'H') TKR-720A only	52	P130	-	Not use.
26	Vss	-	GND.	53	P143	I	T.A/Not use.
27	P13/INT3	I	GND.	54	P142	I	Base/Rep.
28	P12/INT2	I	GND.	55	P141	I	VHF/UHF.
29	P11/INT1	I	ENC-A.	56	P140	I	Not use/Test.
30	P10/INT0	I	ENC-B.	57	NC (Vpp)	-	No connection.
31	PTH03	I	F3.	58	VDD	-	+5V.
32	PTH02	I	F2.	59	P33	O	AUX. (Active 'L')
33	PTH01	I	F1.	60	P32	I	CALL.
34	PTH00	I	F0.	61	P31	I	Serial input.
35	T10	I	GND.	62	P30	I	Serial output.
36	T11	I	GND.	63, 64	P43, P42	O	LED (D23) d, c segment. (Active 'H') TKR-720A only

DESCRIPTION OF COMPONENTS

AVR UNIT (X43-3040-10)

Ref. No.	Parts No.	Descriptions
Q1-Q3	2SC2712(Y)	DC amplifier
Q4	2SB968(Q)	DC amplifier
Q5, Q6	2N5885	DC amplifier
D1	1B2C1	Rectifier
D3	S25VB10	Rectifier
D4	1SS181	Temperature compensate
D5	RD7.5E(B2)	Voltage reference
D6	1SS181	Temperature compensate

DRIVE UNIT (X45-3310-XX)

Ref. No.	Parts No.	Descriptions
Q101	2SC2954	RF amplifier
Q102	2SC2538-22-A	RF amplifier
Q103	2SB951A(Q)	DC amplifier
D101, 102	1SS181	Voltage reference

FINAL UNIT (X45-3320-XX)

Ref. No.	Parts No.	Descriptions
Q2	2SC2694	RF power amplifier
Q3, 4	2SC3326(A)	DC amplifier
D1	SG-5L(R)	Reverse polarity protection
D2, 3	1SS101	RF detector
D4	1SS181	Current steering
D5	1SS181	Voltage reference

2SC2782 (TOSHI-BA)

FINAL UNIT ASS'Y (X60-3230-XX)

Ref. No.	Parts No.	Descriptions
IC101	M57719 M57719L-24	RF amplifier (TX driver)

SIGNALING UNIT (X52-3140-10)

Ref. No.	Parts No.	Descriptions
IC1	MC78L05M	Voltage regulator 5V
IC2	M51943BML	Reset system
IC3	XRA4558F	Data recovery, active filter
IC4	XRA4558F	Active filter
IC5	XRA4558F	Data recovery
IC6, 7	XRA4558F	Active filter
IC8	27C256QJESB	EPROM
IC9	TC74HC573AF	Data latch
IC10	XLJ93LC46	EEPROM
IC11	μPD78310AGF	Microprocessor
Q1	DTC144EK	Level translator
Q2	DTC144EK	Inverter
Q3-7	DTC144EK	DC switch
Q8	DTA114EK	DC switch
Q9	2SC3326(A)	Audio amplifier
Q10	2SJ106(GR)	Audio amplifier
D1, 2	1SS184	Current steering
D3	HSM88AS	Voltage clamp
D4-6	1SS184	Current steering
D7	B30-0838-05	LED (Red)
D8	MTZ8.2JB	Voltage reference

DISPLAY UNIT (X54-3070-XX)

Ref. No.	Parts No.	Descriptions
IC1	75104G-604-1B	Microprocessor
IC2	XLJ93LC46	EEPROM
IC3	M51943BML	Precision reference
IC4	AN78N05	Voltage regulator 5V
IC5	μPC4558C	Audio amplifier
IC6	μPC4558C	Active filter
Q1, 2	DTC114EK	DC switch
Q3	2SA1162(Y)	Digital switch
Q6	2SC3326(A)	AF switch
Q7, 8	DTC114EK	DC switch
D1	B30-0855-05	LED (Red)
D2	B30-0856-05	LED (Green)
D3	B30-0855-05	LED (Red)
D4-6	1SS184	Voltage clamp
D7, 8	1SS181	Current steering
D10, 11	1SS181	Current steering
D13	1SS181	Current steering
D16	B30-0857-05	LED (Yellow)
D17	B30-0856-05	LED (Green)
D18	B30-0857-05	LED (Yellow)
D19, 21	1SS272	Current steering
D22, 23	B38-0308-05	LED display assy
D24	1SS133	Current steering

TKR-720/N/A

DESCRIPTION OF COMPONENTS

TX-RX UNIT (X57-3760-XX)

Ref. No.	Parts No.	Descriptions
IC1	μPC1242H	AF power amplifier
IC2	MB3756	Voltage regulator
IC3	NJM4558D	AF amplifier
IC4	L78N08	Voltage regulator
Q1, 2	2SC2712(Y)	Voltage shift
Q4, 5	2SK125	IF amplifier
Q6	2SK302(GR)	IF amplifier
Q7	2SC2712(Y)	level translator
Q8	DTC114EK	Inverter
Q9, 10	2SC3326(A)	Audio mute switch
Q11	DTC114EK	DC switch
Q12, 13	DTC114EK	Inverter
Q14, 15	2SK125	FiF amplifier
D1, 2	1SV172	TX VCO output mute
D4	ND487C1T	Double balanced modulator
D5~11	1SS184	Current steering
D12	1SS226	Voltage clamp

RX PLL : Z1, TX PLL : Z4 (X58-3140-XX)

Ref. No.	Parts No.	Descriptions
IC1	MB504F	Prescaler
IC2	JLC1075F	PLL system(or JLC1075DW)
Q1	2SC2714(Y)	RF amplifier
Q2~5	DTC114EK	Inverter
D1	RD3.0M(B2)	Level shifter

RX VCO : Z2 (X58-3290-XX)

Ref. No.	Parts No.	Descriptions
Q1	2SK125	Oscillator
Q2	2SC2714(Y)	Buffer amplifier
Q3, 4	2SC3356	Buffer amplifier
D1	1SV166	Tuning

TX VCO : Z5 (X58-3790-XX)

Ref. No.	Parts No.	Descriptions
Q1	2SK125	Oscillator
Q2	2SC2714(Y)	Buffer amplifier
Q3, 4	2SC3356	RF amplifier
D1	1SV166	Tuning
D2	1SV164	Modulator

MIC AMP : Z7 (X59-3210-10)

Ref. No.	Parts No.	Descriptions
IC1	NJM4560M	Mic amplifier/Limiter
IC2	NJM4558M	Limiter
IC3	NJM4558M	Active filter
Q1	2SC3326(A)	Muting switch

IF : Z8 (X59-3220-10)

Ref. No.	Parts No.	Descriptions
IC1	MC3361BD	IF system
Q1	2SC2712(Y)	Noise amplifier
D1	DA204K	Noise detector

BPF/VCA : Z9 (X59-3230-10)

Ref. No.	Parts No.	Descriptions
IC1	NJM4558M	Audio amplifier
IC2	NJM4558M	Active filter
IC3	M5222FP	Electronic attenuator
IC4	NJM4558M	Active filter

PARTS LIST

× New Parts

Parts without Parts No. are not supplied.

Les articles non mentionnés dans le Parts No. ne sont pas fournis.

Teile ohne Parts No. werden nicht geliefert.

TKR-720/N/A

Ref. No. 参照番号	Address 位置	New Parts 新	Parts No. 部品番号	Description 部品名/規格	Desti- nation 仕向	Re- marks 備考
TKR-720/N/A						
1	1A		A01-1059-01	CASE (UPPER)		
2	3A		A01-1060-01	CASE (LOWER)		
3	2C		A13-0684-11	FRAME		
4	3A		A20-2666-11	PANEL		
5	3A		A21-1519-03	DRESSING PLATE	KK2MM2	
5	3A		A21-1519-03	DRESSING PLATE		NMM2
6	3A		A21-1520-03	DRESSING PLATE(REPEAT, MONI)	KK2MM2	
6	3A		A21-1520-03	DRESSING PLATE(REPEAT, MONI)		NMM2
7	2A		A22-0758-01	SUB PANEL		
8	2B		A22-0759-02	SUB PANEL		
9	2H		A23-1508-12	REAR PANEL		
10	2A		A40-0623-02	BOTTOM PLATE (AVR)		
11	2A		A50-0409-03	SIDE PLATE		
12	2B		A50-0410-13	SIDE PLATE		
5	3A		B03-0578-03	DRESSING PLATE	AM AM2	
6	3A		B03-0579-03	DRESSING PLATE	AM AM2	
13	3A		B11-0461-04	FILTER		
			B42-3348-04	LABEL(TX)		
			B42-3349-04	LABEL(RX)		
			B42-3394-14	LABEL(COMPLIANCE NO.)	K	
			B42-3452-04	LABEL(T1.6A 250V)	MM2NM	
			B42-3452-04	LABEL(T1.6A 250V)	AM AM2	
			B42-3452-04	LABEL(T1.6A 250V)	NM2	
14	3F		B44-2163-04	LABEL(UPC)		
15	1F	*	B58-1011-00	CAUTION	NM NM2	
16	2B	*	B72-0118-14	MODEL NAME PLATE	K	
16	2B	*	B72-0119-14	MODEL NAME PLATE	K2	
16	2B		B72-0140-04	MODEL NAME PLATE	MNMAM	
16	2B		B72-0141-04	MODEL NAME PLATE	M2 AM2	
16	2B		B72-0141-04	MODEL NAME PLATE	NM2	
17	1A		B41-0659-14	CAUTION LABEL		
18	1F		B46-0409-40	WARRANTY CARD	KK2	
19	1F		B62-0066-10	INSTRUCTION MANUAL		
C101	1A		C90-2084-05	ELECTRO CAP(AL) 68000UF 25VV		
			E31-3435-05	CONNECTING WIRE		
			E31-3437-15	CONNECTING WIRE (SP)		
			E31-3438-05	CONNECTING WIRE (RED)		
			E31-3439-15	CONNECTING WIRE (BLACK)		
			E31-3446-05	CONNECTING WIRE (2P) POWER SW		
			E40-5197-05	PIN CONNECTOR (7P)		
			E40-5198-05	PIN CONNECTOR (9P)		
			E40-5199-05	PIN CONNECTOR (11P)		
20	2B		E04-0183-05	RF COAXIAL RECEPTACLE(M-M)		
21	2C		E04-0172-05	RF COAXIAL RECEPTACLE(BNC)		
22	2C		E31-3469-05	CONNECTING WIRE (1P-1P)		
23	1B		E30-2125-05	AC POWER CORD	KK2	
23	1B		E30-2153-15	AC POWER CORD	MM2NM	
23	1B		E30-2153-15	AC POWER CORD	AM AM2	
23	1B		E30-2153-15	AC POWER CORD	NM2	
P101	2B		E31-3228-05	SHORT PLUG(ACCESSORY)		
W101	2B		E31-3390-05	CONNECTING WIRE		
W102			E31-3474-15*	CONNECTING WIRE (9P, 5P)		

L:Scandinavia

Y:PX(Far East, Hawaii)

Y:AAFES(Europe)

K:USA

T:England

X:Australia

P:Canada

E:Europe

M:Other Areas

TKR-720 : K,M,K2,M2

TKR-720N : M,M2

TKR-720A : M,M2

⚠ indicates safety critical components.

PARTS LIST

* New Parts

Parts without Parts No. are not supplied.

Les articles non mentionnés dans le Parts No. ne sont pas fournis.

Teile ohne Parts No. werden nicht geliefert.

TKR-720/N/A

Ref. No. 参照番号	Address 位置	New Parts 新	Parts No. 部品番号	Description 部品名 / 規格	Desti- nation 仕向	Re- marks 備考
W103 W106 W107	2B 3C		E31-3473-15 E37-0056-05 E31-3341-05	CONNECTING WIRE (11P) CONNECTING CABLE(BNC-M) CONNECTING WIRE (CH)	AM AM2	
24	1B, 2E		F05-1623-05	FUSE (1.6A)	MM2NM	
24	1B, 2E		F05-1623-05	FUSE (1.6A)	AM AM2	
24	1B, 2E		F05-1623-05	FUSE (1.6A)	NM2	
24	1B, 2E		F06-3024-05	FUSE (3A)	KK2	
25	2E		F51-0017-05	FUSE (15A)	AM AM2	
26	1B		F07-0878-04	COVER (REAR PANEL)	KK2M	
26	1B		F07-0878-04	COVER (REAR PANEL)	M2 NM	
26	1B		F07-0878-04	COVER (REAR PANEL)	NM2	
27	1D		F07-0881-04	COVER (HEAT SINK)		
28	2C		F11-1068-03	SHIELDING COVER (UPPER)		
29	2C		F11-1108-03	SHIELDING COVER(TX,RX FRONT)		
30	1C, 3C		F11-1109-03	SHIELDING COVER(TX,RX UPP/LOW)		
32	2C		G02-0570-04	LEAF SPRING		
33	3A		G09-0405-05	SPRING (VOL, SOL, CH)		
34	2A		G13-0895-04	CUSHION(SP)		
35	3B, 2A		G13-0912-14	CUSHION(PANEL)		
36	3E		H13-0820-04	PACKING FIXTURE		
38	3F		H52-0072-04	ITEM CARTON BOX		
39	1E		H10-2649-02	POLYSTYRENE FOAMED FIX(FRONT)		
40	2F		H10-2650-02	POLYSTYRENE FOAMED FIX(REAR)		
41	2F		H20-1414-03	PROTECTION COVER		
42	2E		H25-0029-04	PROTECTION BAG (60X110)		
43	2F		H25-0105-04	PROTECTION BAG (AC CORD)		
44	3E		H25-0103-04	PROTECTION BAG (DC CORD)	AM AM2	
45	3A		J02-0049-14	FOOT		
46	2B		J19-1433-05	LEAD HOLDER		
47	2D, 3D		J21-4243-04	MOUNTING HARDWARE (TX,RX)		
48	1C, 2C		J21-4244-04	MOUNTING HARDWARE (TX,RX)		
50	2A		J21-4246-04	MOUNTING HARDWARE		
51	2D		J21-4253-04	MOUNTING HARDWARE (HEAT SINK)		
52	2B		J42-0442-05	BUSHING (REAR PANEL)		
53	1B		J42-0489-05	BUSHING (AC CORD)		
54	2C		J42-0452-05	BUSHING		
55	2B		J42-0455-05	BUSHING		
56	2D, 3D		J50-0401-05	HINGE		
57	2A, 2B		J61-0023-05 J61-0307-05	WIRE BAND WIRE BAND		
60	3A		K29-3075-03	KNOB (CH)	AM AM2	
61	2A		K29-3146-04	KNOB (POWER)		
62	3A		K29-3147-03	KNOB (VOL, SOL)		
63	2B, 3B		K29-3148-04	KNOB (TAKE, REPEAT, MONI)		
T101	1A		L01-8341-05	POWER TRANSFORMER	KK2	
T101	1A		L01-8347-05	POWER TRANSFORMER	MM2NM	
T101	1A		L01-8347-05	POWER TRANSFORMER	AM AM2	
T101	1A		L01-8347-05	POWER TRANSFORMER	NM2	
65	2B		N19-0631-05	FLAT WASHER(LEAD HOLDER)		
A	2A, 2B		N09-0704-05	SCREW		
B	2C, 2D		N09-2030-05	SCREW		
C	2B, 2D		N32-3005-46	FLAT HEAD MACHINE SCREW(HING)		
D	1A, 3B		N33-3006-45	OVAL HEAD MACHINE SCREW(CASE)		

L:Scandinavia

K:USA

P:Canada

TKR-720 : K,M,K2,M2

TKR-720N : M,M2

TKR-720A : M,M2

Y:PX(Far East, Hawaii)

T:England

E:Europe

Y:AAFES(Europe)

X:Australia

M:Other Areas

⚠ indicates safety critical components.

PARTS LIST

× New Parts

Parts without Parts No. are not supplied.

Les articles non mentionnés dans le Parts No. ne sont pas fournis.

Teile ohne Parts No. werden nicht geliefert.

TKR-720/N/A
DC BACK UP
MOUNTING BRACKET
AVR UNIT (X43-3040-10)

Ref. No. 参照番号	Address 位置	New Parts 新	Parts No. 部品番号	Description 部品名 / 規格	Desti- nation 仕 向	Re- marks 備考
B	2B, 2C		N35-3006-46	BINDING HEAD MACHINE SCREW		
F	1B		N35-3008-46	BINDING HEAD MACHINE (AVR HEAT		
G	1C		N35-2606-41	BINDING HEAD MACHINE (SIGNAL)		
H	2B, 3C		N87-2606-46	BRAZIER HEAD TAPTITE SCREW		
I	2A, 2D		N87-3008-46	BRAZIER HEAD TAPTITE SCREW		
J	1A		N87-4006-46	BRAZIER HEAD TAPTITE SCR(C101)		
K	3A		N87-4010-46	BRAZIER HEAD TAPTITE SCR(FOOT)		
S101	2A		S40-2450-05	PUSH SWITCH(POWER)		
SP101	3A		T07-0227-25	LOUDSPEAKER		
70	1B, 2B		X43-3040-10	AVR UNIT		
71	1C		X52-3140-10	SIGNALING UNIT		
72	2B, 3B		X54-3070-12	DISPLAY UNIT		KK2MM2
72	2B, 3B		X54-3070-12	DISPLAY UNIT		NMNM2
72	2B, 3B	*	X54-3070-14	DISPLAY UNIT		AM AM2
73	3C		X57-3760-10	TX.RX UNIT		KMAM
73	3C		X57-3760-11	TX.RX UNIT		K2M2
73	3C		X57-3760-11	TX.RX UNIT		AM2
73	3C	*	X57-3760-12	TX.RX UNIT		NM
73	3C	*	X57-3760-13	TX.RX UNIT		NM2
74	1D		X60-3230-10	FINAL UNIT ASSY		KMAM
74	1D		X60-3230-11	FINAL UNIT ASSY		K2M2
74	1D		X60-3230-11	FINAL UNIT ASSY		AM2
74	1D	*	X60-3230-12	FINAL UNIT ASSY		NM
74	1D	*	X60-3230-13	FINAL UNIT ASSY		NM2
DC BACK UP						
76	3B		E30-2076-15	DC CORD (DC BACK UP)		AM AM2
78	1B		E31-3389-15	CONNECTING WIRE(DC BACK UP)		AM AM2
			E31-3455-15	CONNECTING WIRE(DC BACK UP)		AM AM2
S	1A		N87-4014-46	BRAZIER HEAD TAPTITE SCREW		AM AM2
D101	1B		S25VB10	DIODE (DC BACK UP)		AM AM2
MOUNTING BRACKET						
			J21-4250-04	MOUNTING BRACKET		
			N09-0704-05	SCREW		
AVR UNIT (X43-3040-10)						
C1 ,2			CK73FB1H102K	CHIP C 1000PF K		
C3 ,4			C90-0814-05	ELECTRO 4700UF 25WV		
C5			CE04EW1A470M	ELECTRO 47UF 10WV		
C6 ,7			CK73FB1H102K	CHIP C 1000PF K		
C8 -11			CK73BB1H104K	CHIP C 0.10UF K		
C12			CK73FB1H102K	CHIP C 1000PF K		
C13			C90-0814-05	ELECTRO 4700UF 25WV		
C14 -16			CK73FB1H102K	CHIP C 1000PF K		
C17 -20			CK73BB1H104K	CHIP C 0.10UF K		
C101, 102			C91-1075-05	CERAMIC 470PF		
C103			C91-1098-05	CERAMIC 4700PF AC400V		
CN1 ,2			E23-0462-05	TERMINAL		
CN3 ,4			E23-0611-05	TERMINAL		
CN5 -7			E23-0159-05	TERMINAL		
A3	1B		R01-0965-03	HEAT SINK		

L:Scandinavia

K:USA

P:Canada

Y:PX(Far East, Hawaii)

T:England

E:Europe

Y:AAFES(Europe)

X:Australia

M:Other Areas

TKR-720 : K,M,K2,M2
TKR-720N : M,M2
TKR-720A : M,M2

⚠ indicates safety critical components.

PARTS LIST

× New Parts

Parts without Parts No. are not supplied.

Les articles non mentionnés dans le Parts No. ne sont pas fournis.

Teile ohne Parts No. werden nicht geliefert.

AVR UNIT (X43-3040-10)
DRIVE UNIT (X45-3310-XX)

Ref. No. 参照番号	Address 位置	New Parts 新	Parts No. 部品番号	Description 部品名/規格	Desti- nation 仕向	Re- marks 備考
A5	1B		F07-0849-04	COVER		
A9 -12	1B		F20-1106-05 F29-0432-05	INSULATOR INSULATOR		
A1 ,2			J13-0055-15	FUSE HOLDER		
A4	1B		J21-4247-04	MOUNTING HARDWARE		
A6 -8	1B		J32-0906-14	BOSS		
E	1B		N35-3006-46	BINDING HEAD MACHINE SCREW		
I	1B		N87-3008-46	BRAZIER HEAD TAPTITE SCREW		
L	1B		N35-3012-46	BINDING HEAD MACHINE SCREW		
M	1B		N87-4016-46	BRAZIER HEAD TAPTITE SCREW		
R2			RS14AB3A4R7J	FL-PROOF RS 4.7 J 1W		
R3 -5			RD41FB2B273J	CARBON 27K J 1/8W		
R6 ,7			R92-0619-05	FIXED RESISTOR 0.05 5W		
R8			RD41FB2B152J	CARBON 1.5K J 1/8W		
R9			RD41FB2B102J	CARBON 1K J 1/8W		
R10 -12			RD41FB2B391J	CARBON 390 J 1/8W		
R13			RD41FB2B683J	CARBON 68K J 1/8W		
R14			RD41FB2B822J	CARBON 8.2K J 1/8W		
VR1			R12-0440-05	TRIMMING POT.680		
VR2			R12-8406-05	TRIMMING POT.1M		
D1			1B2C1	DIODE		
D3	1B		S25VB10	DIODE		
D4			1SS181	CHIP DIODE		
D5			RD7.5B(B2)	CHIP ZENER DIODE		
D6			1SS181	CHIP DIODE		
Q1 -3			2SC2712(Y)	CHIP TRANSISTOR		
Q4			2SB968(Q)	CHIP TRANSISTOR		
Q5 ,6	1B		2N5885	TRANSISTOR		
DRIVE UNIT (X45-3310-XX) 10 : K,M,AM,NM 11 : K2,M2,AM2,NM2						
C101			CC73FCH1H680J	CHIP C 68PF J		
C102,103			CK73FB1H102K	CHIP C 1000PF K		
C104			CC73FCH1H220J	CHIP C 22PF J		
C105			CC73FCH1H560J	CHIP C 56PF J		
C106,107			CK73FB1H102K	CHIP C 1000PF K		
C108			CC73FCH1H180J	CHIP C 18PF J		
C110			CK73FB1H102K	CHIP C 1000PF K		
C111			CK73FB1H473K	CHIP C 0.047UF K		
C112			C90-2021-05	ELECTRO 10UF 25WV		
C113			CK73FB1H102K	CHIP C 1000PF K		
C114			CK73BB1H473K	CHIP C 0.047UF K		
C115			C90-2021-05	ELECTRO 10UF 25WV		
C116-118			CK73FB1H102K	CHIP C 1000PF K		
C119			C90-2044-05	ELECTRO 1UF 25WV		
C120			C90-2086-05	ELECTRO 22UF 20WV	K2 M2	
C120			C90-2086-05	ELECTRO 22UF 20WV	AM2NM2	
CN101			E04-0159-05	RF COAXIAL CABLE RECEPTACLE		
CN102			E40-0608-05	PIN CONNECTOR (6P)		
L101			L40-6872-80	SMALL FIXED INDUCTOR		
L102			L34-0742-05	COIL(5T)		
L103,104			L34-1087-05	COIL(5T)		
R101			RK73FB2A271J	CHIP R 270 J 1/10W		
R102			RK73FB2A180J	CHIP R 18 J 1/10W		

L:Scandinavia

K:USA

P:Canada

Y:PX(Far East, Hawaii)

T:England

E:Europe

Y:AAFES(Europe)

X:Australia

M:Other Areas

TKR-720 : K,M,K2,M2

TKR-720N : M,M2

TKR-720A : M,M2

⚠ indicates safety critical components.

PARTS LIST

* New Parts

Parts without Parts No. are not supplied.

Les articles non mentionnés dans le Parts No. ne sont pas fournis.

Teile ohne Parts No. werden nicht geliefert.

DRIVE UNIT (X45-3310-XX)

FINAL UNIT (X45-3320-XX)

Ref. No. 参照番号	Address 位置	New Parts 新	Parts No. 部品番号	Description 部品名 / 規格	Desti- nation 仕 向	Re- marks 備考
R103			RK73FB2A180J	CHIP R 18 J 1/10W	KMAMNM	
R103			RK73FB2A330J	CHIP R 33 J 1/10W	K2M2	
R103			RK73FB2A330J	CHIP R 33 J 1/10W	AM2NM2	
R104			RK73FB2A470J	CHIP R 47 J 1/10W		
R105			RK73FB2A152J	CHIP R 1.5K J 1/10W		
R106			RK73FB2A220J	CHIP R 22 J 1/10W		
R107			RK73FB2A470J	CHIP R 47 J 1/10W		
R108			RK73FB2A152J	CHIP R 1.5K J 1/10W		
R109			RK73FB2A331J	CHIP R 330 J 1/10W		
R110			RS14DB3A100J	FL-PROOF RS 10 J 1W		
R111			RD14BB2E271J	RD 270 J 1/4W	KMAMNM	
R111			RD14BB2E151J	RD 150 J 1/4W	K2 M2	
R111			RD14BB2E151J	RD 150 J 1/4W	AM2NM2	
R112			RD14BB2E180J	RD 18 J 1/4W	KMAMNM	
R112			RD14BB2E390J	RD 39 J 1/4W	K2 M2	
R112			RD14BB2E390J	RD 39 J 1/4W	AM2NM2	
R113			RD14BB2E271J	RD 270 J 1/4W	KMAMNM	
R113			RD14BB2E151J	RD 150 J 1/4W	K2 M2	
R113			RD14BB2E151J	RD 150 J 1/4W	AM2NM2	
R114			RK73FB2A102J	CHIP R 1.0K J 1/10W		
D101,102			1SS181	DIODE		
IC101			M57719	IC(POWER MODULE/ 145-175MHz)	KMAMNM	
IC101			M57719L-24	IC(POWER MODULE/ 136-150MHz)	K2M2	
IC101			M57719L-24	IC(POWER MODULE/ 136-150MHz)	AM2NM2	
Q101			2SC2954	TRANSISTOR		
Q102			2SC2538-22-A	TRANSISTOR		
Q103			2SB951A(Q)	TRANSISTOR		
FINAL UNIT (X45-3320-XX) 11 : K,M,AM,NM 12 : K2,M2,AM2,NM2						
C1			CM73F2H220J	CHIP C 22PF J		
C2			CM73F2H470J	CHIP C 47PF J	K2 M2	
C2			CM73F2H470J	CHIP C 47PF J	AM2NM2	
C3			CM73F2H240J	CHIP C 24PF J	KMAMNM	
C3			CM73F2H270J	CHIP C 27PF J	K2M2	
C3			CM73F2H270J	CHIP C 27PF J	AM2NM2	
C5			CM73F2H471J	CHIP C 470PF J		
C7			CM73F2H121J	CHIP C 120PF J	KMAMNM	
C7			CM73F2H181J	CHIP C 180PF J	K2M2	
C7			CM73F2H181J	CHIP C 180PF J	AM2NM2	
C10 ,11			CM73F2H221J	CHIP C 220PF J		
C14 ,15			CM73F2H151J	CHIP C 150PF J		
C20			CE04EWTE221M	ELECTRO 220UF 25WV		
C21			C90-2021-05	ELECTRO 10UF 25WV		
C22			CK73EB1H473K	CHIP C 0.047UF K		
C23			CK73EB1H102K	CHIP C 1000PF K		
C25			CM73F2H121J	CHIP C 120PF J	KMAMNM	
C25		*	CM73F2H161J	CHIP C 160PF J	K2 M2	
C25		*	CM73F2H161J	CHIP C 160PF J	AM2NM2	
C27			CM73F2H471J	CHIP C 470PF J		
C28			CM73F2H101J	CHIP C 100PF J	KMAMNM	
C28			CM73F2H121J	CHIP C 120PF J	K2M2	
C28			CM73F2H121J	CHIP C 120PF J	AM2NM2	
C29 ,30			CM73F2H360J	CHIP C 36PF J	KMAMNM	
C29 ,30			CM73F2H390J	CHIP C 39PF J	K2M2	
C29 ,30			CM73F2H390J	CHIP C 39PF J	AM2NM2	

L:Scandinavia

K:USA

P:Canada

Y:PX(Far East, Hawaii)

T:England

E:Europe

Y:AAFES(Europe)

X:Australia

M:Other Areas

TKR-720 : K,M,K2,M2

TKR-720N : M,M2

TKR-720A : M,M2

△ indicates safety critical components.

PARTS LIST

× New Parts

Parts without Parts No. are not supplied.

Les articles non mentionnés dans le Parts No. ne sont pas fournis.

Teile ohne Parts No. werden nicht geliefert.

**FINAL UNIT (X45-3320-XX)
SIGNALING UNIT (X52-3140-10)**

Ref. No. 参照番号	Address 位 置	New Parts 新	Parts No. 部 品 番 号	Description 部 品 名 / 規 格	Desti- nation 仕 向	Re- marks 備 考
C31			CM73F2H471J	CHIP C 470PF J		
C32			CM73F2H180J	CHIP C 18PF J	KMAMNM	
C32			CM73F2H220J	CHIP C 22PF J	K2M2	
C32			CM73F2H220J	CHIP C 22PF J	AM2NM2	
C33			CM73F2H510J	CHIP C 51PF J	K2M2	
C33			CM73F2H510J	CHIP C 51PF J	AM2NM2	
C33 ,34			CM73F2H390J	CHIP C 39PF J	KMAMNM	
C34			CM73F2H470J	CHIP C 47PF J	K2M2	
C34			CM73F2H470J	CHIP C 47PF J	AM2NM2	
C35			CM73F2H180J	CHIP C 18PF J	KMAMNM	
C36			CC73FCH1H0R5C	CHIP C 0.5PF C		
C37			CK73FB1H102K	CHIP C 1000PF K		
C38			CC73FCH1H050C	CHIP C 5PF C		
C39 ,40			CK73FB1H102K	CHIP C 1000PF K		
C42 -44			CK73FB1H102K	CHIP C 1000PF K		
C47 -49			CK73FB1H102K	CHIP C 1000PF K		
A1			E29-0468-14	TERMINAL(ANT)		
CN2 ,3			E23-0491-15	TERMINAL		
CN4			E40-5166-05	PIN CONNECTOR(6P)		
W1			E31-3273-05	CONNECTING WIRE(5P)		
W8			E33-1855-00	FINISHED WIRE SET		
L1			L34-0951-05	COIL(2.5T)	K2 M2	
L1			L34-0951-05	COIL(2.5T)	AM2NM2	
L1			L34-1039-05	COIL(1.5T)	KMAMNM	
L2			L39-0421-04	COIL		
L4			L34-0452-05	COIL(6T)		
L6			L92-0110-05	FERRITE BEAD		
L9 ,10			L34-1139-05	COIL(0.5T)		
L12			L33-0649-05	CHOKER COIL		
L13 ,14			L34-1232-15	COIL(3.5T)		
L15			L34-1231-15	COIL(1.5T)		
L16			L40-1092-14	SMALL FIXED INDUCTOR		
L18			L34-1231-15	COIL (1.5T)		
L21			L39-0421-04	COIL		
R3			RS14AB3A101J	FL-PROOF RS 100 J 1W		
R5			RS14DB2H151J	FL-PROOF RS 150 J 1/2W		
R6			RS14DB2H181J	FL-PROOF RS 180 J 1/2W		
R7			RK73FB2A561J	CHIP R 560 J 1/10W		
R9			R92-0670-05	CHIP R 0 OHM		
R10			RK73FB2A472J	CHIP R 4.7K J 1/10W		
R11			RK73FB2A101J	CHIP R 100 J 1/10W		
R12			RK73FB2A103J	CHIP R 10K J 1/10W		
R13			RK73FB2A822J	CHIP R 8.2K J 1/10W		
R17			RK73FB2A222J	CHIP R 2.2K J 1/10W		
VR1			R12-3430-05	TRIMMING POT.(10K)		
D1			SG-5L(R)	DIODE		
D2 ,3			1SS101	DIODE		
D4 ,5			1SS181	DIODE		
Q2			2SC2694	TRANSISTOR		
Q3 ,4			2SC3326(A)	TRANSISTOR		
SIGNALING UNIT (X52-3140-10)						
C1			CE04NW1E220M	ELECTRO 22UF 25WV		
C2 ,3			CK73FB1H103K	CHIP C 0.010UF K		

L:Scandinavia

K:USA

P:Canada

Y:PX(Far East, Hawaii)

T:England

E:Europe

Y:AAFES(Europe)

X:Australia

M:Other Areas

TKR-720 : K,M,K2,M2

TKR-720N : M,M2

TKR-720A : M,M2

⚠ indicates safety critical components.

PARTS LIST

* New Parts

Parts without Parts No. are not supplied.

Les articles non mentionnés dans le Parts No. ne sont pas fournis.

Teile ohne Parts No. werden nicht geliefert.

SIGNALLING UNIT (X52-3140-10)

Ref. No. 参照番号	Address 位置	New Parts 新	Parts No. 部品番号	Description 部品名 / 規格	Desti- nation 仕向	Re- marks 備考
C4			CE04NW1C470M	ELECTRO 47UF 16WV		
C5			C92-0004-05	ELECTRO 1.0UF 16WV		
C6			CK73FB1H103K	CHIP C 0.010UF K		
C7			CC73FCH1H101J	CHIP C 100PF J		
C8			C92-0011-05	CHIP TAN 10UF 4WV		
C9			CK73BB1E333K	CHIP C 0.033UF K		
C10			CK73FB1H332K	CHIP C 3300PF K		
C11			CK73BB1H683K	CHIP C 0.068UF K		
C12			CK73FB1H152K	CHIP C 1500PF K		
C13			CK73BB1H104K	CHIP C 0.10UF K		
C14 ,15			CK73FB1H103K	CHIP C 0.010UF K		
C16			C92-0011-05	CHIP TAN 10UF 4WV		
C17			C92-0003-05	CHIP TAN 0.47UF 25WV		
C18 ,19			CC73FCH1H100D	CHIP C 10PF D		
C20			CK73FB1H183K	CHIP C 0.018UF K		
C21			CK73FB1H102K	CHIP C 1000PF K		
C22			CK73BB1E473K	CHIP C 0.047UF K		
C23			CK73BB1E333K	CHIP C 0.033UF K		
C24 ,25			C92-0004-05	ELECTRO 1.0UF 16WV		
C26 -28			CC73FCH1H101J	CHIP C 100PF J		
C29			CK73FB1H103K	CHIP C 0.010UF K		
C30			C92-0011-05	CHIP TAN 10UF 4WV		
C31			CK73FB1H103K	CHIP C 0.010UF K		
C32			C92-0004-05	ELECTRO 1.0UF 16WV		
C33			CK73BB1H104K	CHIP C 0.10UF K		
C34			C92-0004-05	ELECTRO 1.0UF 16WV		
C35 -38			CK73FB1H153K	CHIP C 0.015UF K		
C39			C92-0502-05	ELECTRO 0.33UF 35WV		
C40 ,41			C92-0004-05	ELECTRO 1.0UF 16WV		
C42			CK73FB1H103K	CHIP C 0.010UF K		
C43 -46			CK73FF1E104Z	CHIP C 0.1UF Z		
CN1			E02-2010-05	IC SOCKET (8P)		
CN2			E02-2015-05	IC SOCKET (28P)		
CN3			E40-3256-05	PIN CONNECTOR(12P)		
			E40-3248-05	PIN CONNECTOR(4P)		
			E40-3247-05	PIN CONNECTOR(3P)		
TP1 ,2			E23-0467-05	TERMINAL		
W1 ,2			E31-1448-05	WIRE		
W4			E31-1448-05	WIRE		
W104			E31-3254-05	CONNECTING WIRE		
W105			E31-3255-05	CONNECTING WIRE		
X1			L77-1374-05	CRYSTAL RESONATOR (12MHZ)		
CP1			R90-0598-05	MULTI-COMP 10K/20K		
R1			RK73FB2A100J	CHIP R 10 J 1/10W		
R2			RK73FB2A473J	CHIP R 47K J 1/10W		
R3			RK73FB2A102J	CHIP R 1.0K J 1/10W		
R4 ,5			RK73FB2A473J	CHIP R 47K J 1/10W		
R6 ,7			RK73FB2A273J	CHIP R 27K J 1/10W		
R8			RK73FB2A684J	CHIP R 680K J 1/10W		
R9			R92-0670-05	CHIP R 0 OHM		
R10			RK73FB2A104J	CHIP R 100K J 1/10W		
R11 -13			RK73FB2A683J	CHIP R 68K J 1/10W		
R14			RK73FB2A753J	CHIP R 75K J 1/10W		

L:Scandinavia

K:USA

P:Canada

Y:PX(Far East, Hawaii)

T:England

E:Europe

Y:AAFES(Europe)

X:Australia

M:Other Areas

TKR-720 : K,M,K2,M2

TKR-720N : M,M2

TKR-720A : M,M2

⚠ indicates safety critical components.

PARTS LIST

× New Parts

Parts without Parts No. are not supplied.

Les articles non mentionnés dans le Parts No. ne sont pas fournis.

Teile ohne Parts No. werden nicht geliefert.

SIGNALING UNIT (X52-3140-10)

DISPLAY UNIT (X54-3070-XX)

Ref. No. 参照番号	Address 位置	New Parts 新	Parts No. 部品番号	Description 部品名 / 規格	Desti- nation 仕 向	Re- marks 備考
R15			RK73FB2A563J	CHIP R 56K J 1/10W		
R16 -19			RK73FB2A473J	CHIP R 47K J 1/10W		
R20			RK73FB2A123J	CHIP R 12K J 1/10W		
R21			RK73FB2A153J	CHIP R 15K J 1/10W		
R22 ,23			RK73FB2A103J	CHIP R 10K J 1/10W		
R24 ,25			RK73FB2A394J	CHIP R 390K J 1/10W		
R26			RK73FB2A473J	CHIP R 47K J 1/10W		
R27 -29			RK73FB2A124J	CHIP R 120K J 1/10W		
R30			RK73FB2A183J	CHIP R 18K J 1/10W		
R31			RK73FB2A221J	CHIP R 220 J 1/10W		
R32 ,33			RK73FB2A393J	CHIP R 39K J 1/10W		
R34			RK73FB2A225J	CHIP R 2.2M J 1/10W		
R35 -37			RK73FB2A473J	CHIP R 47K J 1/10W		
R38			R92-0670-05	CHIP R 0 ΩHM		
R39 -41			RK73FB2A473J	CHIP R 47K J 1/10W		
R42 -45			RK73FB2A102J	CHIP R 1.0K J 1/10W		
R46 -50			RK73FB2A473J	CHIP R 47K J 1/10W		
R51			RK73FB2A223J	CHIP R 22K J 1/10W		
R52			RK73FB2A331J	CHIP R 330 J 1/10W		
R53			RK73FB2A394J	CHIP R 390K J 1/10W		
R54			RK73FB2A474J	CHIP R 470K J 1/10W		
R55			RK73FB2A622J	CHIP R 6.2K J 1/10W		
R56			RK73FB2A563J	CHIP R 56K J 1/10W		
R57			RK73FB2A683J	CHIP R 68K J 1/10W		
R58			RK73FB2A153J	CHIP R 15K J 1/10W		
R59 ,60			RK73FB2A222J	CHIP R 2.2K J 1/10W		
R61			RK73FB2A104J	CHIP R 100K J 1/10W		
R62 ,63			RK73FB2A473J	CHIP R 47K J 1/10W		
R64			RK73FB2A102J	CHIP R 1.0K J 1/10W		
R65			RK73FB2A471J	CHIP R 470 J 1/10W		
R66			RK73FB2A473J	CHIP R 47K J 1/10W		
VR1 -5			R12-3099-05	TRIMMING POT.47K		
D1 ,2			1SS184	CHIP DIODE		
D3			HSM88AS	CHIP DIODE		
D4 -6			1SS184	CHIP DIODE		
D7			B30-0838-05	LED		
D8			MTZ8.2JB	ZENER DIODE		
IC1			MC78L05M	IC(VOLTAGE REGULATOR/ +5V)		
IC2			M51943BML	IC(SYSTEM RESET)		
IC3 -7			XRA4558P	IC(OP AMP X2)0rBA4558P		
IC8			27C256QJESB	EPROM		
IC9			TC74HC573AF	IC(8 bit LATCH)		
IC10			XLJ93LC46	EEPROM		
IC11			UPD78310AGP	IC(MICROPROCESSOR)		
Q1 -7			DTC144EK	DIGITAL TRANSISTOR		
Q8			DTA114BK	DIGITAL TRANSISTOR		
Q9			2SC3326(A)	CHIP TRANSISTOR		
Q10			2SJ106(GR)	CHIP FET		
DISPLAY UNIT (X54-3070-XX) 12 : K,K2,M,M2,NM,NM2 14 : AM,AM2						
D1			B30-0855-05	LED(RBD)		
D2			B30-0856-05	LED(GREEN)		
D3			B30-0855-05	LED(RBD)		
D16			B30-0857-05	LED(YELLOW)		

L:Scandinavia

K:USA

P:Canada

Y:PX(Far East, Hawaii)

T:England

E:Europe

Y:AAFES(Europe)

X:Australia

M:Other Areas

TKR-720 : K,M,K2,M2

TKR-720N : M,M2

TKR-720A : M,M2

⚠ indicates safety critical components.

PARTS LIST

× New Parts

Parts without Parts No. are not supplied.

Les articles non mentionnés dans le Parts No. ne sont pas fournis.

Teile ohne Parts No. werden nicht geliefert.

DISPLAY UNIT (X54-3070-XX)

Ref. No. 参照番号	Address 位置	New Parts 新	Parts No. 部品番号	Description 部品名 / 規格	Desti- nation 仕 向	Re- marks 備考
D17 D18 D22 ,23			B30-0856-05 B30-0857-05 B38-0308-05	LED(GREEN) LED(YELLOW) LED ASSY	AM AM2	
C1 C2 ,3 C4 C5 C6			CK73FB1H102K CC73FGH1H330J CS15E1C010M CK73FB1H103K CE04NW1E470M	CHIP C 1000PF K CHIP C 33PF J TANTAL 1.0UF 16WV CHIP C 0.010UF K ELECTRO 47UF 25WV		
C7 ,8 C9 C10 C11 C12			CK73FB1H103K CE04CW1E220M CE04CW1A101M CK73FB1H102K CS15E1C010M	CHIP C 0.010UF K ELECTRO 22UF 25WV ELECTRO 100UF 10WV CHIP C 1000PF K TANTAL 1.0UF 16WV		
C13 C14 C15 -20 C21 C22			CK73FB1H103K CE04CW1E220M CK73FB1H102K CS15E1C100M C92-0004-05	CHIP C 0.010UF K ELECTRO 22UF 25WV CHIP C 1000PF K TANTAL 10UF 16WV CHIP TAN 1.0UF 16WV		
C23 C24 C25 C26 -28 C30			CK73FB1H102K C92-0004-05 CK73FB1H182K CK73FB1H153K CK73FB1H153K	CHIP C 1000PF K CHIP TAN 1.0UF 16WV CHIP C 1800PF K CHIP C 0.015UF K CHIP C 0.015UF K		
C31 C32 C33 C34 ,35 C36 -41			CK73FB1H102K C92-0004-05 CK73FB1H102K CC73FGH1H101J CK73FB1H102K	CHIP C 1000PF K CHIP TAN 1.0UF 16WV CHIP C 1000PF K CHIP C 100PF J CHIP C 1000PF K		
C42 C43 ,44 C45 ,46 C45 ,46			CK73FB1H472K CK73FB1H102K CK73FB1H102K CK73FB1H102K	CHIP C 4700PF K CHIP C 1000PF K CHIP C 1000PF K CHIP C 1000PF K	KK2MM2 NM NM2	
CN1 CN2 CN3 CN4			E40-0218-05 E08-0874-05 E40-3273-05 E40-3271-05 E08-0673-05	SPACER (LED) RECTANGULAR RECEPTACLE(ROM) PIN CONNECTOR (15P) PIN CONNECTOR (13P) RECTANGULAR RECEPTACLE(MIC)		
CN5 CN6 CN7 CN8 CN9			E40-3270-05 E40-3260-05 E40-0274-05 E40-3273-05 E40-3247-05	PIN CONNECTOR (12P) PIN CONNECTOR (2P) PIN CONNECTOR (2P) PIN CONNECTOR (15P) PIN CONNECTOR (3P)	AM AM2	
CN10 CN11 ,12 CN13 JP2 JP3			E40-5191-05 E40-5079-05 E40-5191-05 E33-1854-00 E33-1917-05	PIN CONNECTOR (8P) PIN CONNECTOR (8P) PIN CONNECTOR (8P) WIRE WIRE	AM AM2 AM AM2 AM AM2	
JP4 W1 W2			E37-0310-05 E31-3440-05 E31-3441-05	WIRE (GREEN) CONNECTING WIRE CONNECTING WIRE	AM AM2 AM AM2	
F1			F06-2029-05	FUSE 2A		
X1			L77-1333-05	CRYSTAL RESONATOR (4.195MHZ)		

L:Scandinavia

K:USA

P:Canada

Y:PX(Far East, Hawaii)

T:England

E:Europe

Y:AAFES(Europe)

X:Australia

M:Other Areas

TKR-720 : K,M,K2,M2

TKR-720N : M,M2

TKR-720A : M,M2

⚠ indicates safety critical components.

PARTS LIST

* New Parts

Parts without Parts No. are not supplied.

Les articles non mentionnés dans le Parts No. ne sont pas fournis.

Teile ohne Parts No. werden nicht geliefert.

DISPLAY UNIT (X54-3070-XX)

Ref. No. 参照番号	Address 位置	New Parts 新	Parts No. 部品番号	Description 部品名/規格	Desti- nation 仕向	Re- marks 備考
J4			R92-0670-05	CHIP R 0 0HM		
J7			R92-0670-05	CHIP R 0 0HM		
J9			R92-0670-05	CHIP R 0 0HM		
J11 ,12			R92-0670-05	CHIP R 0 0HM		
J14			R92-0670-05	CHIP R 0 0HM		
R1			RK73FB2A331J	CHIP R 330 J 1/10W		
R3 ,4			RK73FB2A331J	CHIP R 330 J 1/10W		
R5 -8			RK73FB2A102J	CHIP R 1.0K J 1/10W		
R9			RK73FB2A153J	CHIP R 15K J 1/10W		
R10			RK73FB2A102J	CHIP R 1.0K J 1/10W		
R11			RK73FB2A220J	CHIP R 22 J 1/10W		
R12 -15			RK73FB2A223J	CHIP R 22K J 1/10W		
R16			RS14DB3A470J	FL-PROOF RS 47 J 1W		
R17 -19			RK73FB2A102J	CHIP R 1.0K J 1/10W		
R20			RK73FB2A223J	CHIP R 22K J 1/10W		
R22			RK73FB2A473J	CHIP R 47K J 1/10W		
R24 -28			RK73FB2A102J	CHIP R 1.0K J 1/10W		
R30 ,31			RK73FB2A473J	CHIP R 47K J 1/10W		
R32			RK73FB2A101J	CHIP R 100 J 1/10W		
R33			RK73FB2A562J	CHIP R 5.6K J 1/10W		
R34			RK73FB2A681J	CHIP R 680 J 1/10W		
R35			R92-0341-05	FIXED RESISTOR 4.7 J 1/4W		
R38 ,39			RK73FB2A331J	CHIP R 330 J 1/10W		
R40 ,41			RK73FB2A102J	CHIP R 1.0K J 1/10W		
R42			RK73FB2A681J	CHIP R 680 J 1/10W		
R43 ,44			RK73FB2A102J	CHIP R 1.0K J 1/10W		
R45			RK73FB2A473J	CHIP R 47K J 1/10W		
R46			RK73FB2A101J	CHIP R 100 J 1/10W		
R47			RK73FB2A103J	CHIP R 10K J 1/10W		
R48 ,49			RK73FB2A224J	CHIP R 220K J 1/10W		
R50			RK73FB2A394J	CHIP R 390K J 1/10W		
R51			RK73FB2A153J	CHIP R 15K J 1/10W		
R52			RK73FB2A303J	CHIP R 30K J 1/10W		
R53			RK73FB2A224J	CHIP R 220K J 1/10W		
R54			RK73FB2A622J	CHIP R 6.2K J 1/10W		
R55 ,56			RK73FB2A223J	CHIP R 22K J 1/10W		
R57			RK73FB2A183J	CHIP R 18K J 1/10W		
R58			RK73FB2A681J	CHIP R 680 J 1/10W		
R59			RK73FB2A103J	CHIP R 10K J 1/10W		
R61			RS14DB3A1R0J	FL-PROOF RS 1.0 J 1W		
R62 ,63			RK73FB2A223J	CHIP R 22K J 1/10W		
R64			RK73FB2A331J	CHIP R 330 J 1/10W		
R65			RK73FB2A102J	CHIP R 1.0K J 1/10W		
R66			RK73FB2A223J	CHIP R 22K J 1/10W		
R67			RK73FB2A102J	CHIP R 1.0K J 1/10W		
R68			RK73FB2A223J	CHIP R 22K J 1/10W		
R69			RK73FB2A102J	CHIP R 1.0K J 1/10W		
R70			RK73FB2A223J	CHIP R 22K J 1/10W		
R71			RK73FB2A102J	CHIP R 1.0K J 1/10W		
R72			RK73FB2A223J	CHIP R 22K J 1/10W		
R73 ,74			RK73FB2A103J	CHIP R 10K J 1/10W		
R75 ,76			RK73FB2A104J	CHIP R 100K J 1/10W		
R77 -90			RK73FB2A331J	CHIP R 330 J 1/10W	AM AM2	
R92 -94			RK73FB2A473J	CHIP R 47K J 1/10W		
R95			RK73FB2A271J	CHIP R 270 J 1/10W		

L:Scandinavia

K:USA

P:Canada

Y:PX(Far East, Hawaii)

T:England

E:Europe

Y:AAFES(Europe)

X:Australia

M:Other Areas

TKR-720 : K,M,K2,M2

TKR-720N : M,M2

TKR-720A : M,M2

⚠ indicates safety critical components.

PARTS LIST

* New Parts

Parts without Parts No. are not supplied.

Les articles non mentionnés dans le Parts No. ne sont pas fournis.

Teile ohne Parts No. werden nicht geliefert.

DISPLAY UNIT (X54-3070-XX)

TX-RX UNIT (X57-3760-XX)

Ref. No. 参照番号	Address 位置	New Parts 新	Parts No. 部品番号	Description 部品名 / 規格	Desti- nation 仕 向	Re- marks 備考
R96 ,97 R99 ,100 VR1 VR2			R92-0670-05 R92-0670-05 R01-4418-05 R01-3434-05	CHIP R 0 0HM CHIP R 0 0HM POTENTIOMETER(50K)SQL POTENTIOMETER(10K)VOL		
S1			W02-0393-05	ENCODER	AM AM2	
S2 -4			S40-2455-05	PUSH SWITCH		
D4 -6 D7 ,8 D10 ,11 D13 D19			1SS184 1SS181 1SS181 1SS181 1SS272	CHIP DIODE CHIP DIODE CHIP DIODE CHIP DIODE CHIP DIODE		
D21 D21 D24 IC1 IC2			1SS272 1SS272 1SS133 75104G-604-1B XLJ93LC46	CHIP DIODE CHIP DIODE DIODE IC(MICROPROCESSOR) IC(1K EEPROM)	KK2MM2 NM NM2	
IC3 IC4 IC5 ,6 Q1 ,2 Q3			M51943BML AN78N05 UPC4558C DTC114BK 2SA1162(Y)	IC(SYSTEM RESET) IC(VOLTAGE REGULATOR/ +5V) IC(OP AMP X2) DIGITAL TRANSISTOR CHIP TRANSISTOR		
Q6 Q7 ,8			2SC3326(A) DTC114BK	CHIP TRANSISTOR DIGITAL TRANSISTOR		
TX-RX UNIT (X57-3760-XX) 10 : K,M,AM 11 : K2,M2,AM2 12 : NM 13 : NM2						
C1 C2 -4 C5 -7 C8 C9			CE04EW1A101M CK73FB1H471K CC73FCH1H101J CK73EB1H473K C92-0004-05	ELECTRO 100UF 10WV CHIP C 470PF K CHIP C 100PF J CHIP C 0.047UF K CHIP TAN 1.0UF 16WV		
C10 C11 C12 C13 C14			C92-0001-05 CE04EW1A101M CK73FB1H471K CE04EW1A101M CK73FB1H471K	CHIP TAN 0.1UF 35WV ELECTRO 100UF 10WV CHIP C 470PF K ELECTRO 100UF 10WV CHIP C 470PF K		
C15 C16 ,17 C18 -20 C21 C22			CE04EW1A101M CK73FB1H471K CC73FCH1H101J CK73EB1H473K C92-0004-05	ELECTRO 100UF 10WV CHIP C 470PF K CHIP C 100PF J CHIP C 0.047UF K CHIP TAN 1.0UF 16WV		
C23 C24 C26 C27 C28 -34			C92-0001-05 CK73FB1H103K CK73FB1H103K CE04EW1A101M CK73FB1H471K	CHIP TAN 0.1UF 35WV CHIP C 0.010UF K CHIP C 0.010UF K ELECTRO 100UF 10WV CHIP C 470PF K		
C35 C36 C37 C38 C39			CE04EW1A101M CK73FB1H223K CC73FCH1H101J CE04EW1A101M CE04EW1A470M	ELECTRO 100UF 10WV CHIP C 0.022UF K CHIP C 100PF J ELECTRO 100UF 10WV ELECTRO 47UF 10WV		
C44 C57 ,58 C59 C60 -63			CE04EW1A470M CC73FCH1H101J CC73FCH1H331J CK73FB1H103K	ELECTRO 47UF 10WV CHIP C 100PF J CHIP C 330PF J CHIP C 0.010UF K		

L:Scandinavia

K:USA

P:Canada

Y:PX(Far East, Hawaii)

T:England

E:Europe

Y:AAFES(Europe)

X:Australia

M:Other Areas

TKR-720 : K,M,K2,M2

TKR-720N : M,M2

TKR-720A : M,M2

⚠ indicates safety critical components.

PARTS LIST

x New Parts

Parts without Parts No. are not supplied.

Les articles non mentionnés dans le Parts No. ne sont pas fournis.

Teile ohne Parts No. werden nicht geliefert.

TX-RX UNIT (X57-3760-XX)

Ref. No. 参照番号	Address 位置	New Parts 新	Parts No. 部品番号	Description 部品名 / 規格	Desti- nation 仕 向	Re- marks 備考
C64			CE04EW1E100M	ELECTRO 10UF 25WV		
C65			CK73FB1H103K	CHIP C 0.010UF K		
C66			C90-2041-05	ELECTRO 10UF 10WV		
C67			C92-0007-05	CHIP TAN 2.2UF 20WV		
C68 ,69			CS15E0J100M	TANTAL 10UF 6.3WV		
C70			CS15E1C10DM	TANTAL 10UF 16WV		
C71			CE04EW1A101M	ELECTRO 100UF 10WV		
C72			CE04EW1A221M	ELECTRO 220UF 10WV		
C73			CK73FB1H103K	CHIP C 0.010UF K		
C74			CS15E1C010M	TANTAL 1.0UF 16WV		
C75			CK73FB1H103K	CHIP C 0.010UF K		
C76			CS15E1C010M	TANTAL 1.0UF 16WV		
C77			CK73FB1H471K	CHIP C 470PF K		
C78 ,79			CE04EW1A470M	ELECTRO 47UF 10WV		
C80			CE04EW1C100M	ELECTRO 10UF 16WV		
C81			CK73FB1H103K	CHIP C 0.010UF K		
C82			CE04EW1A470M	ELECTRO 47UF 10WV		
C83			CE04EW1E471M	ELECTRO 470UF 25WV		
C84			C90-2030-05	ELECTRO 1000UF 10WV		
C85			CK73EB1H104K	CHIP C 0.10UF K		
C86			C92-0004-05	CHIP TAN 1.0UF 16WV		
C87			CE04EW1A470M	ELECTRO 47UF 10WV		
C88			CK73FB1H103K	CHIP C 0.010UF K		
C89			CE04EW1A470M	ELECTRO 47UF 10WV		
C90			CK73FB1H103K	CHIP C 0.010UF K		
C91			CE04EW1C100M	ELECTRO 10UF 16WV		
C92			CE04EW1A470M	ELECTRO 47UF 10WV		
C93 -95			CK73FB1H103K	CHIP C 0.010UF K		
C96 -101			CK73FB1H471K	CHIP C 470PF K		
C102			CC73FRH1H080D	CHIP C 8PF D	KMAMNM	
C102			CC73FRH1H100D	CHIP C 10PF D	K2M2	
C102			CC73FRH1H100D	CHIP C 10PF D	AM2NM2	
C103			CC73FRH1H390J	CHIP C 39PF J	KMAMNM	
C103			CC73FRH1H560J	CHIP C 56PF J	K2M2	
C103			CC73FRH1H560J	CHIP C 56PF J	AM2NM2	
C104			CC73FCH1H020C	CHIP C 2.0PF C	KMAMNM	
C104			CC73FCH1H1R5C	CHIP C 1.5PF C	K2M2	
C104			CC73FCH1H1R5C	CHIP C 1.5PF C	AM2NM2	
C105			CC73FCH1H0R5C	CHIP C 0.5PF C		
C106			CC73FRH1H080D	CHIP C 8PF D	KMAMNM	
C106			CC73FRH1H090D	CHIP C 9PF D	K2M2	
C106			CC73FRH1H090D	CHIP C 9PF D	AM2NM2	
C107			CC73FRH1H560J	CHIP C 56PF J	KMAMNM	
C107			CC73FRH1H750J	CHIP C 75PF J	K2M2	
C107			CC73FRH1H750J	CHIP C 75PF J	AM2NM2	
C108			CK73FB1H102K	CHIP C 1000PF K		
C109			CC73FRH1H430J	CHIP C 43PF J	KMAMNM	
C109			CC73FRH1H820J	CHIP C 82PF J	K2M2	
C109			CC73FRH1H820J	CHIP C 82PF J	AM2NM2	
C110			CC73FCH1H020C	CHIP C 2.0PF C	KMAMNM	
C110			CC73FCH1H1R5C	CHIP C 1.5PF C	K2M2	
C110			CC73FCH1H1R5C	CHIP C 1.5PF C	AM2NM2	
C111			CC73FCH1H0R5C	CHIP C 0.5PF C		
C112			CC73FRH1H070D	CHIP C 7PF D	KMAMNM	
C112			CC73FRH1H090D	CHIP C 9PF D	K2M2	

L:Scandinavia

K:USA

P:Canada

Y:PX(Far East, Hawaii)

T:England

E:Europe

Y:AAFES(Europe)

X:Australia

M:Other Areas

TKR-720 : K,M,K2,M2

TKR-720N : M,M2

TKR-720A : M,M2

⚠ indicates safety critical components.

PARTS LIST

× New Parts

Parts without Parts No. are not supplied.

Les articles non mentionnés dans le Parts No. ne sont pas fournis.

Teile ohne Parts No. werden nicht geliefert.

TX-RX UNIT (X57-3760-XX)

Ref. No. 参照番号	Address 位置	New Parts 新	Parts No. 部品番号	Description 部品名 / 规格	Desti- nation 仕 向	Re- marks 備考
C112			CC73FRH1H090D	CHIP C 9PF D	AM2NM2	
C113			CC73PCH1H020C	CHIP C 2.0PF C	KMAMNM	
C113			CC73PCH1H1R5C	CHIP C 1.5PF C	K2M2	
C113			CC73PCH1H1R5C	CHIP C 1.5PF C	AM2NM2	
C114			CC73PCH1H010C	CHIP C 1PF C		
C115			CC73FRH1H090D	CHIP C 9PF D	KMAMNM	
C115			CC73FRH1H100D	CHIP C 10PF D	K2M2	
C115			CC73FRH1H100D	CHIP C 10PF D	AM2NM2	
C116			CC73FRH1H220J	CHIP C 22PF J	KMAMNM	
C116			CC73FRH1H330J	CHIP C 33PF J	K2M2	
C116			CC73FRH1H330J	CHIP C 33PF J	AM2NM2	
CN1			E04-0171-05	RF COAXIAL CABLE RECEPTACLE		
CN5			E40-3091-05	PIN CONNECTOR(3P)		
CN6			E40-5069-05	PIN CONNECTOR(12P)		
CN7			E40-3092-05	PIN CONNECTOR(4P)		
CN8			E40-0573-05	PIN CONNECTOR(5P)		
CN9 ,10			E04-0154-05	RF COAXIAL CABLE RECEPTACLE		
TP1 -3			E23-0464-05	TERMINAL		
W1			E33-1859-00	FINISHED WIRE SET		
A1			F10-1366-04	SHIELDING PLATE		
A2 -6			F11-0844-05	SHIELDING COVER		
			G02-0598-04	LEAF SPRING		
U	3C		N87-2608-46	BRAZIER HEAD TAPTEE SCREW		
CF1			L72-0339-05	CERAMIC FILTER(CFV455D)	KMAMK2	
CF1			L72-0339-05	CERAMIC FILTER(CFV455D)	M2 AM2	
CF1			L72-0360-05	CERAMIC FILTER(CFV455G)	NM NM2	
L1			L40-2211-81	SMALL FIXED INDUCTOR(220UH)		
L2			L40-1021-13	SMALL FIXED INDUCTOR(1MH)		
L3 ,4			L40-2211-81	SMALL FIXED INDUCTOR(220UH)		
L5			L40-1021-13	SMALL FIXED INDUCTOR(1MH)		
L6			L40-2211-81	SMALL FIXED INDUCTOR(220UH)		
L11 ,12			L39-0451-05	COIL		
L13			L40-4782-14	SMALL FIXED INDUCTOR(0.47UH)		
L14			L40-5682-14	SMALL FIXED INDUCTOR(0.56UH)		
L15			L40-2201-14	SMALL FIXED INDUCTOR(22UH)		
L16 ,17			L34-2160-05	IFT(21.4MHz)		
L18			L30-0503-05	IFT(455kHz)		
L19			L15-0016-05	LOW-FREQUENCY CHOKE COIL		
L20 ,21			L34-4059-05	COIL		
L22 ,23			L40-4791-14	SMALL FIXED INDUCTOR(4.7UH)		
L24 -26			L34-4059-05	COIL		
L27			L33-0649-05	CHOKE COIL		
X1			L77-1348-05	CRYSTAL RESONATOR(20.945MHz)		
XF1			L71-0274-05	MCP(21F15C)	KMAMK2	
XF1			L71-0274-05	MCP(21F15C)	M2 AM2	
XF1			L71-0417-05	MCP(21F7.5C)	NM NM2	
Z3			L77-1338-05	TCXO(12.8MHz)		
Z6			L77-1488-05	VCXO(12.8MHz) 0rL77-1388-05		
R1			RK73PB2A332J	CHIP R 3.3K J 1/10W		
R2			RK73PB2A122J	CHIP R 1.2K J 1/10W		
R3 ,4			RK73PB2A102J	CHIP R 1.0K J 1/10W		
R5 ,6			RK73PB2A472J	CHIP R 4.7K J 1/10W		

L:Scandinavia

K:USA

P:Canada

Y:PX(Far East, Hawaii)

T:England

E:Europe

Y:AAFES(Europe)

X:Australia

M:Other Areas

TKR-720 : K,M,K2,M2

TKR-720N : M,M2

TKR-720A : M,M2

⚠ indicates safety critical components.

PARTS LIST

x New Parts

Parts without Parts No. are not supplied.

Les articles non mentionnés dans le Parts No. ne sont pas fournis.

Teile ohne Parts No. werden nicht geliefert.

TX-RX UNIT (X57-3760-XX)

Ref. No. 参照番号	Address 位置	New Parts 新	Parts No. 部品番号	Description 部品名 / 規格	Desti- nation 仕向	Re- marks 備考
R7			RK73FB2A221J	CHIP R 220 J 1/10W		
R8			RK73FB2A271J	CHIP R 270 J 1/10W		
R9			RK73FB2A180J	CHIP R 18 J 1/10W		
R10			RK73FB2A271J	CHIP R 270 J 1/10W		
R11			RK73FB2A332J	CHIP R 3.3K J 1/10W		
R12			RK73FB2A122J	CHIP R 1.2K J 1/10W		
R13 ,14			RK73FB2A102J	CHIP R 1.0K J 1/10W		
R15 ,16			RK73FB2A472J	CHIP R 4.7K J 1/10W		
R17			RK73FB2A221J	CHIP R 220 J 1/10W		
R18			RK73FB2A681J	CHIP R 680 J 1/10W		
R19 ,20			RK73FB2A821J	CHIP R 820 J 1/10W		
R21			RK73FB2A101J	CHIP R 100 J 1/10W		
R22			RK73FB2A103J	CHIP R 10K J 1/10W		
R23			RK73FB2A123J	CHIP R 12K J 1/10W		
R24			RK73FB2A821J	CHIP R 820 J 1/10W		
R25			RK73FB2A473J	CHIP R 47K J 1/10W		
R26			RK73FB2A563J	CHIP R 56K J 1/10W		
R27			RK73FB2A103J	CHIP R 10K J 1/10W		
R34			RK73FB2A330J	CHIP R 33 J 1/10W		
R35			RK73FB2A182J	CHIP R 1.8K J 1/10W	KMAMK2	
R35			RK73FB2A182J	CHIP R 1.8K J 1/10W	M2 AM2	
R35			RK73FB2A122J	CHIP R 1.2K J 1/10W	NM NM2	
R36			RK73FB2A100J	CHIP R 10 J 1/10W		
R37			RK73FB2A152J	CHIP R 1.5K J 1/10W		
R38			RK73FB2A681J	CHIP R 680 J 1/10W		
R39			RK73FB2A560J	CHIP R 56 J 1/10W		
R41			RK73FB2A333J	CHIP R 33K J 1/10W	KMAMK2	
R41			RK73FB2A333J	CHIP R 33K J 1/10W	M2 AM2	
R41			R92-0670-05	CHIP R 0 OHM	NM NM2	
R42			RK73FB2A682J	CHIP R 6.8K J 1/10W		
R43			RK73FB2A683J	CHIP R 68K J 1/10W		
R44			RK73FB2A222J	CHIP R 2.2K J 1/10W		
R45			RK73FB2A221J	CHIP R 220 J 1/10W		
R46			RK73FB2A392J	CHIP R 3.9K J 1/10W		
R47			RK73FB2A222J	CHIP R 2.2K J 1/10W		
R48			RK73FB2A103J	CHIP R 10K J 1/10W		
R49			RK73FB2A182J	CHIP R 1.8K J 1/10W		
R50			RK73FB2A222J	CHIP R 2.2K J 1/10W		
R51 -54			RK73FB2A223J	CHIP R 22K J 1/10W		
R55			RK73FB2A221J	CHIP R 220 J 1/10W		
R56			RK73FB2A123J	CHIP R 12K J 1/10W		
R57			RK73FB2A2R2J	CHIP R 2.2 J 1/10W		
R58 ,59			RK73FB2A223J	CHIP R 22K J 1/10W		
R60			RK73FB2A102J	CHIP R 1.0K J 1/10W		
R61			RK73FB2A104J	CHIP R 100K J 1/10W		
R62			RK73FB2A222J	CHIP R 2.2K J 1/10W		
R63			R92-0670-05	CHIP R 0 OHM		
R64 ,65			RK73FB2A223J	CHIP R 22K J 1/10W		
R66 ,67			RK73FB2A471J	CHIP R 470 J 1/10W		
R68 ,69			RK73FB2A103J	CHIP R 10K J 1/10W		
R70 ,71			RK73FB2A473J	CHIP R 47K J 1/10W		
R72			RK73FB2A681J	CHIP R 680 J 1/10W		
R73			RK73FB2A101J	CHIP R 100 J 1/10W		
R74			RK73FB2A562J	CHIP R 5.6K J 1/10W		
R75			RK73FB2A223J	CHIP R 22K J 1/10W		

L:Scandinavia

K:USA

P:Canada

Y:PX(Far East, Hawaii)

T:England

E:Europe

Y:AAFES(Europe)

X:Australia

M:Other Areas

TKR-720 : K,M,K2,M2

TKR-720N : M,M2

TKR-720A : M,M2

 indicates safety critical components.

PARTS LIST

× New Parts

Parts without Parts No. are not supplied.

Les articles non mentionnés dans le Parts No. ne sont pas fournis.

Teile ohne Parts No. werden nicht geliefert.

TX-RX UNIT (X57-3760-XX)

RX PLL : Z1, TX PLL : Z4 (X58-3140-XX)

Ref. No. 参照番号	Address 位置	New Parts 新	Parts No. 部品番号	Description 部品名 / 規格	Desti- nation 仕 向	Re- marks 備考
R76			RK73FB2A332J	CHIP R 3.3K J 1/10W		
R78			RK73FB2A330J	CHIP R 33 J 1/10W		
R79			RK73FB2A102J	CHIP R 1.0K J 1/10W		
VR1			R12-0420-05	TRIMMING POT.(500)		
VR2 ,3			R12-4408-05	TRIMMING POT.(50K)		
K1			S51-1435-05	RELAY		
D1 ,2			1SV172	DIODE		
D4			ND487C1T	DBM		
D5 -11			1SS184	DIODE		
D12			1SS226	DIODE		
IC1			UPC1242H	IC(AF POWER AMP)		
IC2			MB3756	IC(REGULATOR/OUTPUT.SEL)		
IC3			NJM4558D	IC(OP AMP X2)		
IC4			L78N08	IC(REGULATOR/8V)		
Q1 ,2			2SC2712(Y)	TRANSISTOR		
Q4 ,5			2SK125	FET		
Q6			2SK302(GR)	FET		
Q7			2SC2712(Y)	TRANSISTOR		
Q8			DTC114EK	DIGITAL TRANSISTOR		
Q9 ,10			2SC3326(A)	TRANSISTOR		
Q11 -13			DTC114EK	DIGITAL TRANSISTOR		
Q14 ,15			2SK125	FET		
TH1			112-203-2	THERMISTOR(20K)		
TH2			112-101-2	THERMISTOR(100)		
Z1			X58-3140-10	SUB UNIT(RX PLL)	KMAMK2	
Z1			X58-3140-10	SUB UNIT(RX PLL)	M2 AM2	
Z1			X58-3140-51	SUB UNIT(RX PLL)	NM NM2	
Z2			X58-3290-10	SUB UNIT(RX VCO)	KMAMNM	
Z2			X58-3290-11	SUB UNIT(RX VCO)	K2M2	
Z2			X58-3290-11	SUB UNIT(RX VCO)	AM2NM2	
Z4			X58-3140-10	SUB UNIT(TX PLL)	KMAMK2	
Z4			X58-3140-10	SUB UNIT(TX PLL)	M2 AM2	
Z4			X58-3140-51	SUB UNIT(TX PLL)	NM NM2	
Z5			X58-3790-10	SUB UNIT(TX VCO)	KMAMNM	
Z5			X58-3790-11	SUB UNIT(TX VCO)	K2M2	
Z5			X58-3790-11	SUB UNIT(TX VCO)	AM2NM2	
Z7			X59-3210-10	MODULE UNIT(MIC AMP)		
Z8			X59-3220-10	MODULE UNIT(IP)		
Z9			X59-3230-10	MODULE UNIT(BPF/VCA)		
RX PLL : Z1, TX PLL : Z4 (X58-3140-XX) 10 : K, K2, M, M2, AM, AM2 51 : NM, NM2						
C1 -7			CK73FB1H102K	CHIP C 1000PF K		
C8			CC73FCH1H080D	CHIP C 8.0PF D		
C9			CK73FB1H102K	CHIP C 1000PF K		
C10			C92-0009-05	CHIP TAN 4.7UF 10WV		
C11 ,12			CC73FCH1H070D	CHIP C 7.0PF D		
C13 ,14			CK73FB1H102K	CHIP C 1000PF K		
-			E23-0471-05	TERMINAL		
A1			F11-1092-04	SHIELDING COVER		
L1			L40-2281-80	SMALL FIXED INDUCTOR(220NH)		
R1			RK73FB2A472J	CHIP R 4.7K J 1/10W		
R2			RK73FB2A102J	CHIP R 1.0K J 1/10W		

L:Scandinavia

K:USA

P:Canada

Y:PX(Far East, Hawaii)

T:England

E:Europe

Y:AAFES(Europe)

X:Australia

M:Other Areas

TKR-720 : K, M, K2, M2

TKR-720N : M, M2

TKR-720A : M, M2

⚠ indicates safety critical components.

PARTS LIST

* New Parts

Parts without Parts No. are not supplied.

Les articles non mentionnés dans le Parts No. ne sont pas fournis.

Teile ohne Parts No. werden nicht geliefert.

RX PLL : Z1, TX PLL : Z4 (X58-3140-XX)

RX VCO : Z2 (X58-3290-XX)

Ref. No. 参照番号	Address 位置	New Parts 新	Parts No. 部品番号	Description 部品名 / 規格	Desti- nation 仕 向	Re- marks 備考
R3 ,4			RK73FB2A270J	CHIP R 27 J 1/10W		
R5			RK73FB2A182J	CHIP R 1.8K J 1/10W		
R6 -9			RK73FB2A103J	CHIP R 10K J 1/10W		
R10			R92-0670-05	CHIP R 0 OHM		
R11			RK73FB2A103J	CHIP R 10K J 1/10W		
R12			RK73FB2A471J	CHIP R 470 J 1/10W		
R13			R92-0670-05	CHIP R 0 OHM		
R14			RK73FB2A472J	CHIP R 4.7K J 1/10W		
R15			RK73FB2A562J	CHIP R 5.6K J 1/10W		
D1			RD3.0M(B2)	CHIP ZENER DIODE(3.0V)		
IC1			MB504F	IC(MODULUS PRE SCALER)		
IC2			JLC1075F	IC(PLL FREQ SYNTHESIZER)		
Q1			2SC2714(Y)	CHIP TRANSISTOR		
Q2 -5			DTC1146K	DIGITAL TRANSISTOR		
RX VCO : Z2 (X58-3290-XX) 10 : K,M,AM,NM 11 : K2,M2,AM2,NM2						
C1			CK73FB1H102K	CHIP C 1000PF K		
C2			CC73FCH1H220J	CHIP C 22PF J	K2M2	
C2			CC73FCH1H220J	CHIP C 22PF J	AM2NM2	
C2			CC73FCH1H270J	CHIP C 27PF J	KMAMNM	
C3			CC73FCH1H121J	CHIP C 120PF J		
C4			CC73FCH1H150J	CHIP C 15PF J	KMAMNM	
C4			CC73FCH1H180J	CHIP C 18PF J	K2M2	
C4			CC73FCH1H180J	CHIP C 18PF J	AM2NM2	
C5			CC73FCH1H060D	CHIP C 6PF D	KMAMNM	
C5			CC73FCH1H090D	CHIP C 9PF D	K2M2	
C5			CC73FCH1H090D	CHIP C 9PF D	AM2NM2	
C6			CC73FCH1H100D	CHIP C 10PF D	KMAMNM	
C6			CC73FCH1H150J	CHIP C 15PF J	K2M2	
C6			CC73FCH1H150J	CHIP C 15PF J	AM2NM2	
C7			CK73FB1H102K	CHIP C 1000PF K		
C8			CC73FCH1H030C	CHIP C 3PF C		
C9			CK73FB1H102K	CHIP C 1000PF K		
C10			CC73FCH1H150J	CHIP C 15PF J		
C11			CC73FCH1H010C	CHIP C 1PF C	KMAMNM	
C11			CC73FCH1H030C	CHIP C 3PF C	K2M2	
C11			CC73FCH1H030C	CHIP C 3PF C	AM2NM2	
C12			CC73FCH1H080D	CHIP C 8PF D		
C13			CC73FCH1H050C	CHIP C 5PF C		
C14 -17			CK73FB1H102K	CHIP C 1000PF K		
C18			CE04CW1A101M	ELBCTRM 100UF 10WV		
C19			CC73FCH1H180J	CHIP C 18PF J		
C20			CC73FCH1H070D	CHIP C 7PF D		
C21			CC73FCH1H180J	CHIP C 18PF J		
C22			CK73FB1H102K	CHIP C 1000PF K		
TC1			C05-0363-05	TRIMMING CAP (18P)		
A1			F11-1060-04	SHIELDING COVER		
-			E23-0603-05	TERMINAL		
L1			L40-1092-81	CHIP INDUCTOR (1UH)		
L2			L34-2309-05	OSCILLATING COIL	KMAMNM	
L2			L32-0658-05	OSCILLATING COIL	K2M2	
L2			L32-0658-05	OSCILLATING COIL	AM2NM2	
L3 ,4			L40-1092-81	CHIP INDUCTOR (1UH)		
L5			L40-1881-80	CHIP INDUCTOR (180NH)		

L:Scandinavia

K:USA

P:Canada

Y:PX(Far East, Hawaii)

T:England

E:Europe

Y:AAFES(Europe)

X:Australia

M:Other Areas

TKR-720 : K,M,K2,M2

TKR-720N : M,M2

TKR-720A : M,M2

⚠ indicates safety critical components.

PARTS LIST

× New Parts

Parts without Parts No. are not supplied.

Les articles non mentionnés dans le Parts No. ne sont pas fournis.

Teile ohne Parts No. werden nicht geliefert.

RX VCO : Z2 (X58-3290-XX)

TX VCO : Z5 (X58-3790-XX)

Ref. No. 参照番号	Address 位 置	New Parts 新	Parts No. 部 品 番 号	Description 部 品 名 / 規 格	Desti- nation 仕 向	Re- marks 備考
L6			L40-4772-80	CHIP INDUCTOR (47NH)		
R1			RK73FB2A221J	CHIP R 220 J 1/10W		
R2			RK73FB2A104J	CHIP R 100K J 1/10W		
R3	, 4		RK73FB2A331J	CHIP R 330 J 1/10W		
R5			RK73FB2A101J	CHIP R 100 J 1/10W		
R6			RK73FB2A153J	CHIP R 15K J 1/10W		
R7			RK73FB2A562J	CHIP R 5.6K J 1/10W		
R8			RK73FB2A331J	CHIP R 330 J 1/10W		
R9			RK73FB2A101J	CHIP R 100 J 1/10W		
R10			RK73FB2A183J	CHIP R 18K J 1/10W		
R11			RK73FB2A272J	CHIP R 2.7K J 1/10W		
R12			RK73FB2A392J	CHIP R 3.9K J 1/10W		
R13			RK73FB2A562J	CHIP R 5.6K J 1/10W		
R14			RK73FB2A121J	CHIP R 120 J 1/10W		
R15			RK73FB2A560J	CHIP R 56 J 1/10W		
R16			RK73FB2A101J	CHIP R 100 J 1/10W		
D1			1SV166	VARI-CAP DIODE		
Q1			2SK125	PBT		
Q2			2SC2714(Y)	CHIP TRANSISTOR		
Q3	, 4		2SC3356	CHIP TRANSISTOR		
TX VCO : Z5 (X58-3790-XX) 10 : K,M,AM,NM 11 : K2,M2,AM2,NM2						
C1			CK73FB1H102K	CHIP C 1000PF K		
C2			CC73FCH1H150J	CHIP C 15PF J	K2M2	
C2			CC73FCH1H150J	CHIP C 15PF J	AM2NM2	
C2			CC73FCH1H180J	CHIP C 18PF J	KMAMNM	
C3			CC73FCH1H470J	CHIP C 47PF J	K2M2	
C3			CC73FCH1H470J	CHIP C 47PF J	AM2NM2	
C3			CC73FCH1H560J	CHIP C 56PF J	KMAMNM	
C4			CC73FCH1H090D	CHIP C 9PF D	KMAMNM	
C4			CC73FCH1H120J	CHIP C 12PF J	K2M2	
C4			CC73FCH1H120J	CHIP C 12PF J	AM2NM2	
C5			CC73FCH1H040C	CHIP C 4PF C	KMAMNM	
C5			CC73FCH1H060D	CHIP C 6PF D	K2M2	
C5			CC73FCH1H060D	CHIP C 6PF D	AM2NM2	
C6			CC73FCH1H060D	CHIP C 6PF D	KMAMNM	
C6			CC73FCH1H100D	CHIP C 10PF D	K2M2	
C6			CC73FCH1H100D	CHIP C 10PF D	AM2NM2	
C7			CK73FB1H102K	CHIP C 1000PF K		
C8			CC73FCH1H030C	CHIP C 3PF C		
C9			CK73FB1H102K	CHIP C 1000PF K		
C10			CC73FCH1H150J	CHIP C 15PF J		
C11			CC73FCH1H010C	CHIP C 1PF C	KMAMNM	
C11			CC73FCH1H030C	CHIP C 3PF C	K2M2	
C11			CC73FCH1H030C	CHIP C 3PF C	AM2NM2	
C12			CC73FCH1H080D	CHIP C 8PF D		
C13			CC73FCH1H050C	CHIP C 5PF C		
C14 -17			CK73FB1H102K	CHIP C 1000PF K		
C18			CE04CW1A101M	ELECTRO 100UF 10WV		
C19			CK73FB1H102K	CHIP C 1000PF K		
C20			CC73FCH1H010C	CHIP C 1PF C		
C21			CK73FB1H103K	CHIP C 0.010UF K		
C22			CK73FB1H102K	CHIP C 1000PF K		
TC1			C05-0353-05	TRIMMING CAP (10PF)		

L:Scandinavia

K:USA

P:Canada

Y:PX(Far East, Hawaii)

T:England

E:Europe

Y:AAFES(Europe)

X:Australia

M:Other Areas

TKR-720 : K,M,K2,M2

TKR-720N : M,M2

TKR-720A : M,M2

⚠ indicates safety critical components.

PARTS LIST

* New Parts

Parts without Parts No. are not supplied.

Les articles non mentionnés dans le Parts No. ne sont pas fournis.

Teile ohne Parts No. werden nicht geliefert.

TX VCO : Z5 (X58-3790-XX)

MIC AMP : Z7 (X59-3210-10)

Ref. No. 参照番号	Address 位置	New Parts 新	Parts No. 部品番号	Description 部品名 / 規格	Desti- nation 仕向	Re- marks 備考
A1			E23-0603-05	TERMINAL		
			F11-1060-04	SHIELD CASE		
L1			L40-1092-81	CHIP INDUCTOR (1UH)	KMAMNM K2M2 AM2NM2	
L2			L34-2309-05	COIL(4T)		
L2			L32-0658-05	COIL(4T)		
L2			L32-0658-05	COIL(4T)		
L3			L40-1092-81	CHIP INDUCTOR (1UH)		
L4			L40-1092-81	CHIP INDUCTOR (1UH)		
L5			L40-1881-80	CHIP INDUCTOR (180NH)		
L6			L40-1092-81	CHIP INDUCTOR (1UH)		
R1			RK73FB2A221J	CHIP R 220 J 1/10W		
R2			RK73FB2A104J	CHIP R 100K J 1/10W		
R3			RK73FB2A101J	CHIP R 100 J 1/10W		
R4			RK73FB2A331J	CHIP R 330 J 1/10W		
R5			RK73FB2A101J	CHIP R 100 J 1/10W		
R6			RK73FB2A153J	CHIP R 15K J 1/10W		
R7			RK73FB2A562J	CHIP R 5.6K J 1/10W		
R8			RK73FB2A331J	CHIP R 330 J 1/10W		
R9			RK73FB2A101J	CHIP R 100 J 1/10W		
R10			RK73FB2A183J	CHIP R 18K J 1/10W		
R11			RK73FB2A272J	CHIP R 2.7K J 1/10W		
R12			RK73FB2A392J	CHIP R 3.9K J 1/10W		
R13			RK73FB2A562J	CHIP R 5.6K J 1/10W		
R14			RK73FB2A121J	CHIP R 120 J 1/10W		
R15			RK73FB2A560J	CHIP R 56 J 1/10W		
R16			RK73FB2A101J	CHIP R 100 J 1/10W		
R17			R92-0687-05	CHIP R 0 OHM		
R18 ,19			RK73FB2A104J	CHIP R 100K J 1/10W		
R20			RK73FB2A101J	CHIP R 100 J 1/10W		
D1			1SV166	VARI-CAP DIODE		
D2			1SV164	VARI-CAP DIODE		
Q1			2SK125	FET		
Q2			2SC2714(Y)	CHIP TRANSISTOR		
Q3 ,4			2SC3356	CHIP TRANSISTOR		
MIC AMP : Z7 (X59-3210-10)						
C1			CC73FCH1H101J	CHIP C 100PF J		
C2			C92-0004-05	CHIP TAN 1.0UF 16WV		
C3 ,4			CK73FB1H222K	CHIP C 0.022UF K		
C5			CC73FCH1H330J	CHIP C 33PF J		
C6			C92-0009-05	CHIP TAN 4.7UF 10WV		
C7			C92-0004-05	CHIP TAN 1.0UF 16WV		
C8			CC73FCH1H101J	CHIP C 100PF J		
C9			C92-0004-05	CHIP TAN 1.0UF 16WV		
C10			CK73FB1H123K	CHIP C 0.012UF K		
C11			CK73FB1H222K	CHIP C 220PF K		
C12			CC73FCH1H330J	CHIP C 33PF J		
C13			C92-0004-05	CHIP TAN 1.0UF 16WV		
C14			CK73FB1H222K	CHIP C 220PF K		
C15			CK73FB1H392K	CHIP C 3900PF K		
C16			CC73FCH1H221J	CHIP C 220PF J		
C17			CK73FB1H472K	CHIP C 4700PF K		
C18			C92-0004-05	CHIP TAN 1.0UF 16WV		

L:Scandinavia

K:USA

P:Canada

Y:PX(Far East, Hawaii)

T:England

E:Europe

Y:AAFES(Europe)

X:Australia

M:Other Areas

TKR-720 : K,M,K2,M2

TKR-720N : M,M2

TKR-720A : M,M2

 indicates safety critical components.

PARTS LIST

× New Parts

Parts without Parts No. are not supplied.

Les articles non mentionnés dans le Parts No. ne sont pas fournis.

Teile ohne Parts No. werden nicht geliefert.

RX VCO : Z2 (X58-3290-XX)

TX VCO : Z5 (X58-3790-XX)

Ref. No. 参照番号	Address 位置	New Parts 新	Parts No. 部品番号	Description 部品名 / 規格	Desti- nation 仕向	Re- marks 備考
L6			L40-4772-80	CHIP INDUCTOR (47NH)		
R1			RK73FB2A221J	CHIP R 220 J 1/10W		
R2			RK73FB2A104J	CHIP R 100K J 1/10W		
R3	, 4		RK73FB2A331J	CHIP R 330 J 1/10W		
R5			RK73FB2A101J	CHIP R 100 J 1/10W		
R6			RK73FB2A153J	CHIP R 15K J 1/10W		
R7			RK73FB2A562J	CHIP R 5.6K J 1/10W		
R8			RK73FB2A331J	CHIP R 330 J 1/10W		
R9			RK73FB2A101J	CHIP R 100 J 1/10W		
R10			RK73FB2A183J	CHIP R 18K J 1/10W		
R11			RK73FB2A272J	CHIP R 2.7K J 1/10W		
R12			RK73FB2A392J	CHIP R 3.9K J 1/10W		
R13			RK73FB2A562J	CHIP R 5.6K J 1/10W		
R14			RK73FB2A121J	CHIP R 120 J 1/10W		
R15			RK73FB2A560J	CHIP R 56 J 1/10W		
R16			RK73FB2A101J	CHIP R 100 J 1/10W		
D1			1SV166	VARI-CAP DIODE		
Q1			2SK125	PBT		
Q2			2SC2714(Y)	CHIP TRANSISTOR		
Q3	, 4		2SC3356	CHIP TRANSISTOR		
TX VCO : Z5 (X58-3790-XX) 10 : K,M,AM,NM 11 : K2,M2,AM2,NM2						
C1			CK73FB1H102K	CHIP C 1000PF K		
C2			CC73FCH1H150J	CHIP C 15PF J	K2M2	
C2			CC73FCH1H150J	CHIP C 15PF J	AM2NM2	
C2			CC73FCH1H180J	CHIP C 18PF J	KMAMNM	
C3			CC73FCH1H470J	CHIP C 47PF J	K2M2	
C3			CC73FCH1H470J	CHIP C 47PF J	AM2NM2	
C3			CC73FCH1H560J	CHIP C 56PF J	KMAMNM	
C4			CC73FCH1H090D	CHIP C 9PF D	KMAMNM	
C4			CC73FCH1H120J	CHIP C 12PF J	K2M2	
C4			CC73FCH1H120J	CHIP C 12PF J	AM2NM2	
C5			CC73FCH1H040C	CHIP C 4PF C	KMAMNM	
C5			CC73FCH1H060D	CHIP C 6PF D	K2M2	
C5			CC73FCH1H060D	CHIP C 6PF D	AM2NM2	
C6			CC73FCH1H060D	CHIP C 6PF D	KMAMNM	
C6			CC73FCH1H100D	CHIP C 10PF D	K2M2	
C6			CC73FCH1H100D	CHIP C 10PF D	AM2NM2	
C7			CK73FB1H102K	CHIP C 1000PF K		
C8			CC73FCH1H030C	CHIP C 3PF C		
C9			CK73FB1H102K	CHIP C 1000PF K		
C10			CC73FCH1H150J	CHIP C 15PF J		
C11			CC73FCH1H010C	CHIP C 1PF C	KMAMNM	
C11			CC73FCH1H030C	CHIP C 3PF C	K2M2	
C11			CC73FCH1H030C	CHIP C 3PF C	AM2NM2	
C12			CC73FCH1H080D	CHIP C 8PF D		
C13			CC73FCH1H050C	CHIP C 5PF C		
C14	-17		CK73FB1H102K	CHIP C 1000PF K		
C18			CB04CW1A101M	ELECTRO 100UF 10WV		
C19			CK73FB1H102K	CHIP C 1000PF K		
C20			CC73FCH1H010C	CHIP C 1PF C		
C21			CK73FB1H103K	CHIP C 0.010UF K		
C22			CK73FB1H102K	CHIP C 1000PF K		
TC1			C05-0353-05	TRIMMING CAP (10PF)		

L:Scandinavia

K:USA

P:Canada

Y:PX(Far East, Hawaii)

T:England

E:Europe

Y:AAFES(Europe)

X:Australia

M:Other Areas

TKR-720 : K,M,K2,M2

TKR-720N : M,M2

TKR-720A : M,M2

⚠ indicates safety critical components.

PARTS LIST

× New Parts

Parts without Parts No. are not supplied.

Les articles non mentionnés dans le Parts No. ne sont pas fournis.

Teile ohne Parts No. werden nicht geliefert.

MIC AMP : Z7 (X59-3210-10)

IF : Z8 (X59-3220-10)

Ref. No. 参照番号	Address 位置	New Parts 新	Parts No. 部品番号	Description 部品名/規格	Desti- nation 仕向	Re- marks 備考
-			E23-0471-05	TERMINAL		
R1			RK73FB2A473J	CHIP R 47K J 1/10W		
R2			RK73FB2A223J	CHIP R 22K J 1/10W		
R3			RK73FB2A561J	CHIP R 560 J 1/10W		
R4			RK73FB2A681J	CHIP R 680 J 1/10W		
R5			RK73FB2A561J	CHIP R 560 J 1/10W		
R6			RK73FB2A104J	CHIP R 100K J 1/10W		
R7			RK73FB2A102J	CHIP R 1.0K J 1/10W		
R8			RK73FB2A333J	CHIP R 33K J 1/10W		
R9			RK73FB2A393J	CHIP R 39K J 1/10W		
R10			RK73FB2A104J	CHIP R 100K J 1/10W		
R11			RK73FB2A683J	CHIP R 68K J 1/10W		
R12			RK73FB2A224J	CHIP R 220K J 1/10W		
R13			RK73FB2A474J	CHIP R 470K J 1/10W		
R14			RK73FB2A123J	CHIP R 12K J 1/10W		
R15			RK73FB2A154J	CHIP R 150K J 1/10W		
R16			RK73FB2A272J	CHIP R 2.7K J 1/10W		
R17			RK73FB2A822J	CHIP R 8.2K J 1/10W		
R18			RK73FB2A103J	CHIP R 10K J 1/10W		
R19 ,20			RK73FB2A104J	CHIP R 100K J 1/10W		
R21			RK73FB2A103J	CHIP R 10K J 1/10W		
R22			RK73FB2A272J	CHIP R 2.7K J 1/10W		
R23			RK73FB2A393J	CHIP R 39K J 1/10W		
R24			RK73FB2A123J	CHIP R 12K J 1/10W		
R25			RK73FB2A333J	CHIP R 33K J 1/10W		
R26 ,27			RK73FB2A472J	CHIP R 4.7K J 1/10W		
R28			RK73FB2A683J	CHIP R 68K J 1/10W		
IC1			NJM4560M	IC(OP AMP X2)		
IC2 ,3			NJM4558M	IC(OP AMP X2)		
Q1			2SC3326(A)	CHIP TRANSISTOR		
IF : Z8 (X59-3220-10)						
C1			CK73FB1H102K	CHIP C 1000PF K		
C2			CC73FCH1H220J	CHIP C 22PF J		
C3			CC73FCH1H470J	CHIP C 47PF J		
C4 -7			CK73BB1E104K	CHIP C 0.10UF K		
C8			C92-0003-05	CHIP TAN 0.47UF 25WV		
C9 ,10			CC73FCH1H680J	CHIP C 68PF J		
C11			CK73FB1H332K	CHIP C 3300PF K		
C12			CK73FB1H102K	CHIP C 1000PF K		
C14			C92-0003-05	CHIP TAN 0.47UF 25WV		
C17			CK73FB1E223K	CHIP C 0.022UF K		
C19			CK73FB1H102K	CHIP C 1000PF K		
C20			CC73FCH1H470J	CHIP C 47PF J		
-			E23-0471-05	TERMINAL		
R1			RK73FB2A203J	CHIP R 20K J 1/10W		
R3			RK73FB2A272J	CHIP R 2.7K J 1/10W		
R4			RK73FB2A334J	CHIP R 330K J 1/10W		
R5 ,6			RK73FB2A153J	CHIP R 15K J 1/10W		
R7			RK73FB2A821J	CHIP R 820 J 1/10W		
R10			RK73FB2A224J	CHIP R 220K J 1/10W		
R13			RK73FB2A392J	CHIP R 3.9K J 1/10W		
R14			RK73FB2A223J	CHIP R 22K J 1/10W		

L:Scandinavia

K:USA

P:Canada

Y:PX(Far East, Hawaii)

T:England

E:Europe

Y:AAFES(Europe)

X:Australia

M:Other Areas

TKR-720 : K,M,K2,M2

TKR-720N : M,M2

TKR-720A : M,M2

⚠ indicates safety critical components.

PARTS LIST

× New Parts

Parts without Parts No. are not supplied.

Les articles non mentionnés dans le Parts No. ne sont pas fournis.

Teile ohne Parts No. werden nicht geliefert.

IF : Z8 (X59-3220-10)

BPF/VCA : Z9 (X59-3230-10)

FINAL ASSY UNIT (X60-3230-XX)

Ref. No. 参照番号	Address 位置	New Parts 新	Parts No. 部品番号	Description 部品名 / 規格	Desti- nation 仕 向	Re- marks 備考
R15 R16			RK73FB2A821J RK73FB2A223J	CHIP R 820 J 1/10W CHIP R 22K J 1/10W		
D1 IC1 Q1			DA204K MC3361BD 2SC2712(Y)	CHIP DIODE IC(OP AMP SYSTEM) CHIP TRANSISTOR		
BPF/VCA : Z9 (X59-3230-10)						
C1 -4 C5 -9 C10 C11 C12			C93-0502-05 C93-0501-05 CK73FB1H222K C92-0004-05 CK73FB1H472K	CHIP C 1800PF G CHIP C 680PF G CHIP C 2200PF K CHIP TAN 1.0UF 16WV CHIP C 4700PF K		
C13 C14			CK73FB1H102K C92-0004-05	CHIP C 1000PF K CHIP TAN 1.0UF 16WV		
-			E23-0471-05	TERMINAL		
R1 R2 R3 R4 R5			RK73FB2A273J RK73FB2A822J RK73FB2A184J RK73FB2A224J RK73FB2A394J	CHIP R 27K J 1/10W CHIP R 8.2K J 1/10W CHIP R 180K J 1/10W CHIP R 220K J 1/10W CHIP R 390K J 1/10W		
R6 R7 R8 R9 R10			RK73FB2A134G RK73FB2A105G RK73FB2A683G RK73FB2A105G RK73FB2A514G	CHIP R 130K G 1/10W CHIP R 1.0M G 1/10W CHIP R 68K G 1/10W CHIP R 1.0M G 1/10W CHIP R 510K G 1/10W		
R11 R12 R13 R14 ,15 R16			RK73FB2A105G RK73FB2A514G RK73FB2A303G RK73FB2A473J RK73FB2A472J	CHIP R 1.0M G 1/10W CHIP R 510K G 1/10W CHIP R 30K G 1/10W CHIP R 47K J 1/10W CHIP R 4.7K J 1/10W		
R17 R18 R19 R20 ,21 R22			RK73FB2A101J RK73FB2A183J RK73FB2A124J RK73FB2A223J RK73FB2A183J	CHIP R 100 J 1/10W CHIP R 18K J 1/10W CHIP R 120K J 1/10W CHIP R 22K J 1/10W CHIP R 18K J 1/10W		
R23			R92-0670-05	CHIP R 0 OHM		
IC1 ,2 IC3 IC4			NJM4558M M5222FP NJM4558M	IC(OP AMP X2) IC(OP AMP X2) IC(OP AMP X2)		
FINAL ASSY UNIT (X60-3230-XX) 10 : K,M,AM 11 : K2,M2,AM2 12 : NM 13 : NM2						
J1 W2 W6 100	3D		E31-6028-05 E04-0167-05 E31-3256-05 E31-3123-05 E37-0059-15	CONNECTING WIRE RF COAXIAL CABLE RECEPTACLE CONNECTING WIRE CONNECTING WIRE(TX) DC CABLE		
101 102 103	2D 1D 2D		F01-0966-11 F11-1115-02 F11-1119-04	HEAT SINK SHIELDING COVER SHIELDING COVER		
104	2D		G10-0668-04	FELT		
105 106	1D 3D		J21-4245-04 J19-1431-05 J19-1433-05	MOUNTING HARDWARE(FINAL UNIT) LEAD HOLDER LEAD HOLDER		

L:Scandinavia

K:USA

P:Canada

Y:PX(Far East, Hawaii)

T:England

E:Europe

Y:AAFES(Europe)

X:Australia

M:Other Areas

TKR-720 : K,M,K2,M2

TKR-720N : M,M2

TKR-720A : M,M2

⚠ indicates safety critical components.

PARTS LIST

× New Parts

Parts without Parts No. are not supplied.

Les articles non mentionnés dans le Parts No. ne sont pas fournis.

Teile ohne Parts No. werden nicht geliefert.

FINAL ASSY UNIT (X60-3230-XX)

Ref. No. 参照番号	Address 位置	New Parts 新	Parts No. 部品番号	Description 部品名 / 規格	Desti- nation 仕 向	Re- marks 備考
109	1D		N16-0040-41	SPRING WASHER		
I	1D		N87-3008-46	SECOND BRAZERTAP TIGHT SCREW		
N	1D, 2D		N67-3010-41	SEMUS SCREW (MODULE TR)		
O	1D		N32-3008-41	FLAT HEAD MACHINE SCREW		
P	1D		N35-3008-41	BINDING HEAD MACHINE SCREW		
R	3D		N90-3008-46	TP HEAD MACHINE SCREW		
V	1D		N35-4006-46	SECOND BRAZERTAP TIGHT SCREW		
W	1D		N89-3010-45	BINDING HEAD MACHINE SCREW		
107	2D		X45-3310-10	DRIVE UNIT	KMAMNM	
107	2D		X45-3310-11	DRIVE UNIT	K2M2	
107	2D		X45-3310-11	DRIVE UNIT	AM2NM2	
108	2D		X45-3320-11	FINAL UNIT	KMAMNM	
108	2D		X45-3320-12	FINAL UNIT	K2M2	
108	2D		X45-3320-12	FINAL UNIT	AM2NM2	

L:Scandinavia

K:USA

P:Canada

Y:PX(Far East, Hawaii)

T:England

E:Europe

Y:AAFES(Europe)

X:Australia

M:Other Areas

TKR-720 : K,M,K2,M2

TKR-720N : M,M2

TKR-720A : M,M2

⚠ indicates safety critical components.

TKR-720/N/A

EXPLODED VIEW

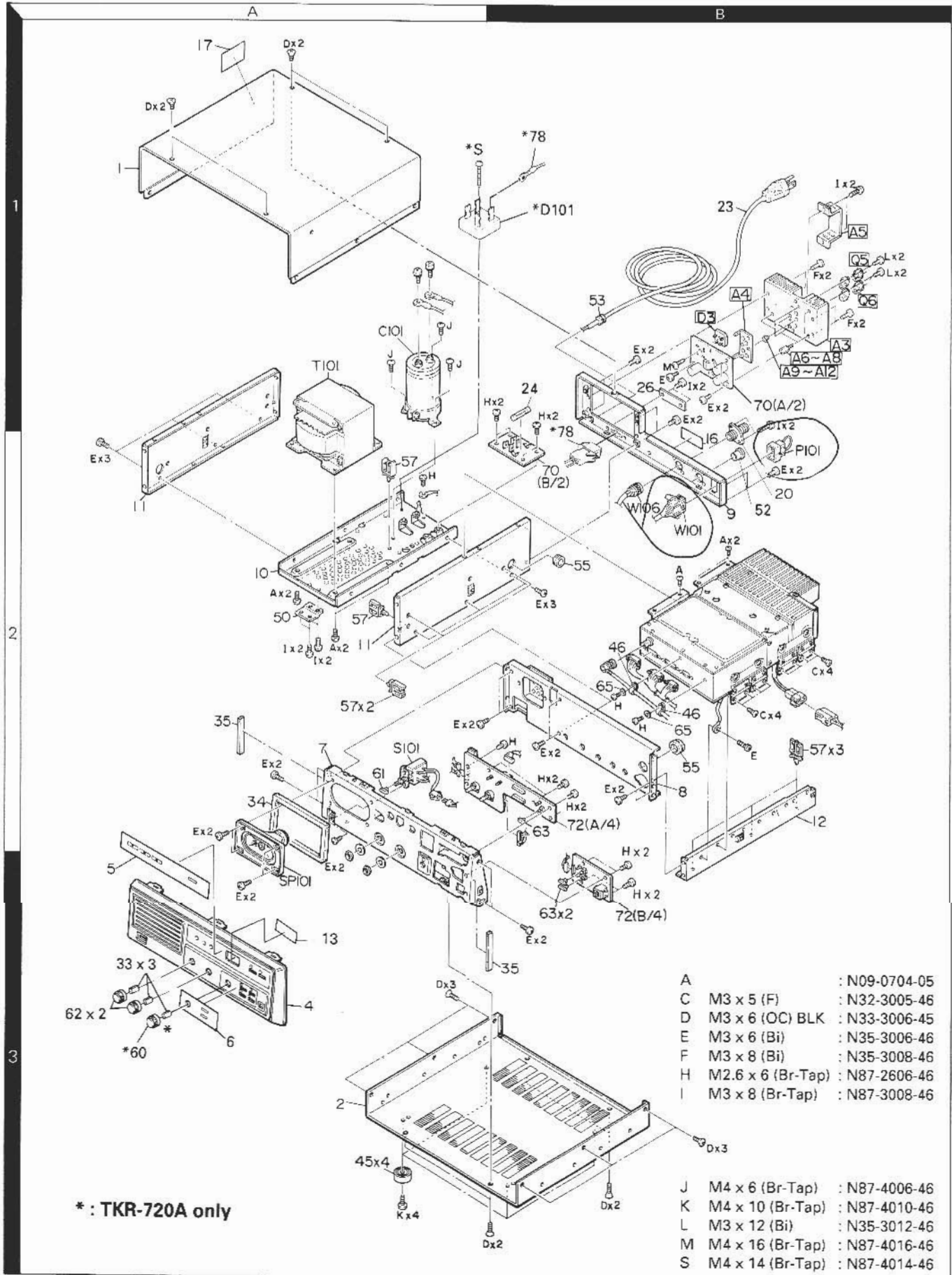

* : TKR-720A only

- | | | |
|---|-------------------|---------------|
| A | : | N09-0704-05 |
| C | M3 x 5 (F) | : N32-3005-46 |
| D | M3 x 6 (OC) BLK | : N33-3006-45 |
| E | M3 x 6 (Bi) | : N35-3006-46 |
| F | M3 x 8 (Bi) | : N35-3008-46 |
| H | M2.6 x 6 (Br-Tap) | : N87-2606-46 |
| I | M3 x 8 (Br-Tap) | : N87-3008-46 |
| J | M4 x 6 (Br-Tap) | : N87-4006-46 |
| K | M4 x 10 (Br-Tap) | : N87-4010-46 |
| L | M3 x 12 (Bi) | : N35-3012-46 |
| M | M4 x 16 (Br-Tap) | : N87-4016-46 |
| S | M4 x 14 (Br-Tap) | : N87-4014-46 |

TKR-720/N/A

EXPLODED VIEW

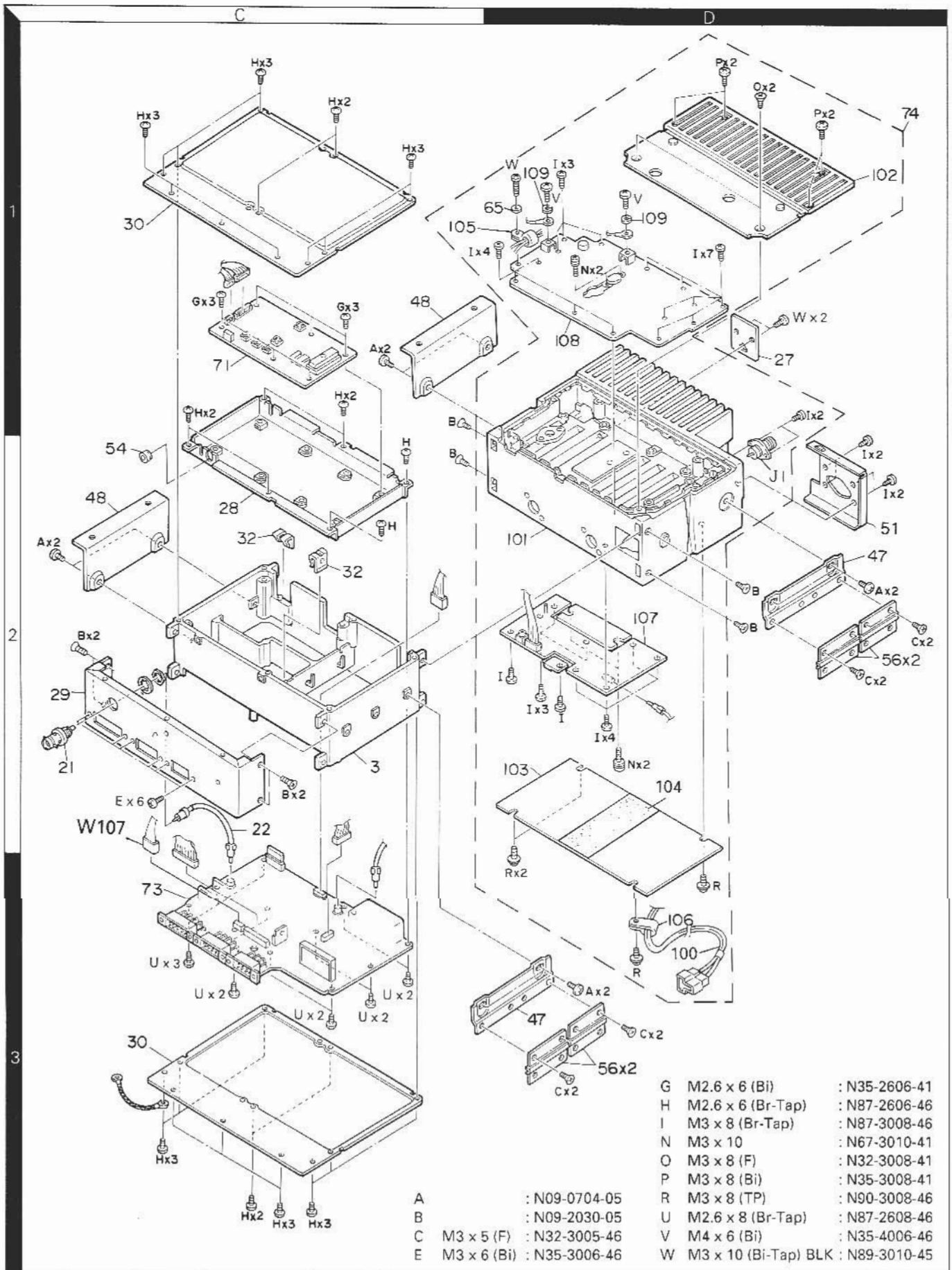

A	: N09-0704-05	G	M2.6 x 6 (Bi)	: N35-2606-41
B	: N09-2030-05	H	M2.6 x 6 (Br-Tap)	: N87-2606-46
C	M3 x 5 (F) : N32-3005-46	I	M3 x 8 (Br-Tap)	: N87-3008-46
E	M3 x 6 (Bi) : N35-3006-46	N	M3 x 10	: N67-3010-41
		O	M3 x 8 (F)	: N32-3008-41
		P	M3 x 8 (Bi)	: N35-3008-41
		R	M3 x 8 (TP)	: N90-3008-46
		U	M2.6 x 8 (Br-Tap)	: N87-2608-46
		V	M4 x 6 (Bi)	: N35-4006-46
		W	M3 x 10 (Bi-Tap) BLK	: N89-3010-45

PACKING

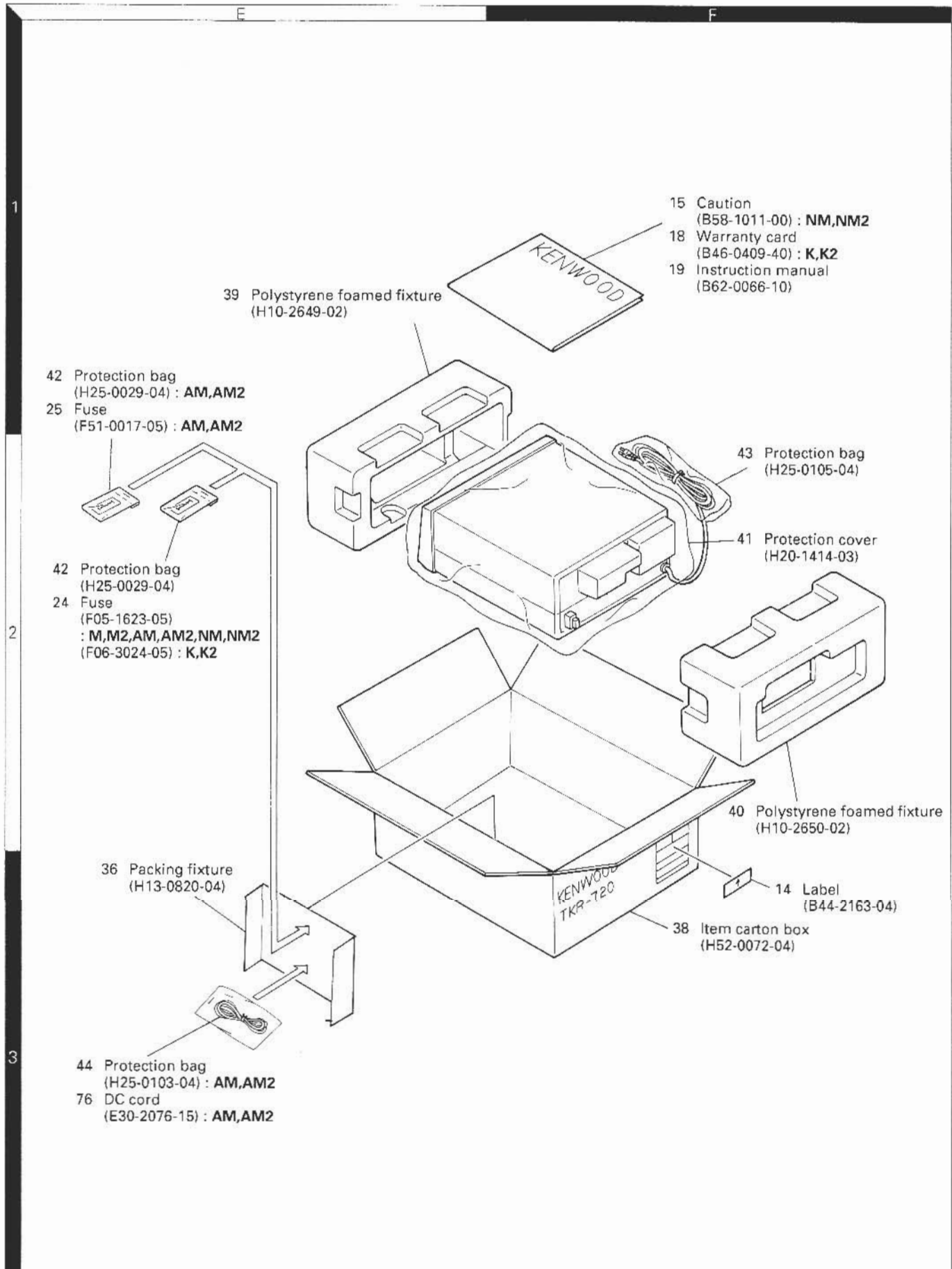

ADJUSTMENT

Test Equipment Required for Alignment

Test Equipment	Major Specifications	
1. Standard Signal Generator (SSG)	Frequency Range Modulation Output	136 to 174MHz Frequency modulation and external modulation 0.1μV to greater than 1mV
2. Power meter	Input Impedance Operation Frequency Measurement Capability	50Ω 136 to 174MHz or more Vicinity of 50W
3. Deviation meter	Frequency Range	136 to 174MHz
4. Digital Volt Meter (DVM)	Measuring Range Accuracy	1 to 10V DC High input impedance for minimum circuit loading
5. Oscilloscope		DC through 30MHz
6. High Sensitivity Frequency Counter	Frequency Range Frequency Stability	10Hz to 600MHz 0.2ppm or less
7. Ammeter		15A
8. AF Volt Meter (AF VTVM)	Frequency Range Voltage Range	50Hz to 10kHz 3mV to 3V
9. Audio Generator (AG)	Frequency Range Output	50Hz to 5kHz or more 0 to 1V
10. Distortion Meter	Capability Input Level	3% or less at 1kHz 50mV to 10Vrms
11. Voltmeter	Measuring Range Input Impedance	10 to 1.5V DC or less 50kΩ/V or greater
12. 4Ω Dummy Load		Approx. 4Ω, 3W

The set has been adjusted for the frequencies shown in the following table. When required, re-adjust them following the adjustment procedure to obtain the frequencies you want in actual operation.

Type	RX freq' (MHz)	TX freq' (MHz)
K,M,NM,AM	173.900	168.900
K2,M2,NM2,AM2	149.900	144.900

TKR-720 : K,K2,M,M2

TKR-720N : M,M2

TKR-720A : M,M2

Signaling

CH	RX		TX	
	QT (Hz)	DQT	QT (Hz)	DQT
1	210.7			023
2	67		77	
3	192.8		179.9	
4	77			754
5	88.5		167.9	
6	100			351

MIC connector front view

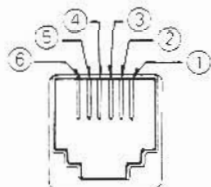

- ① SB
- ② PTTG
- ③ PTT
- ④ MICG
- ⑤ MIC
- ⑥ HOOK

- The following test cables are recommended.

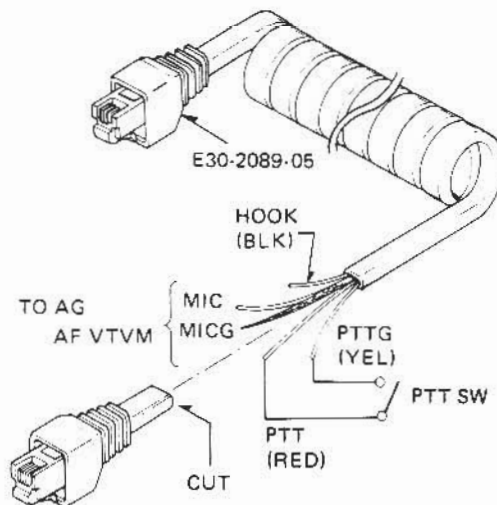

Test cable for Microphone input

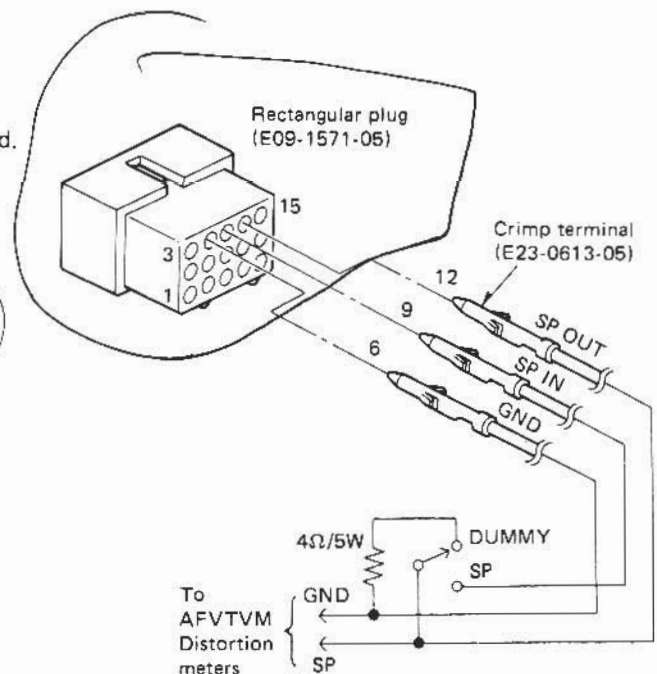

Test cable for Speaker output

ADJUSTMENT

Adjustment location

Top view

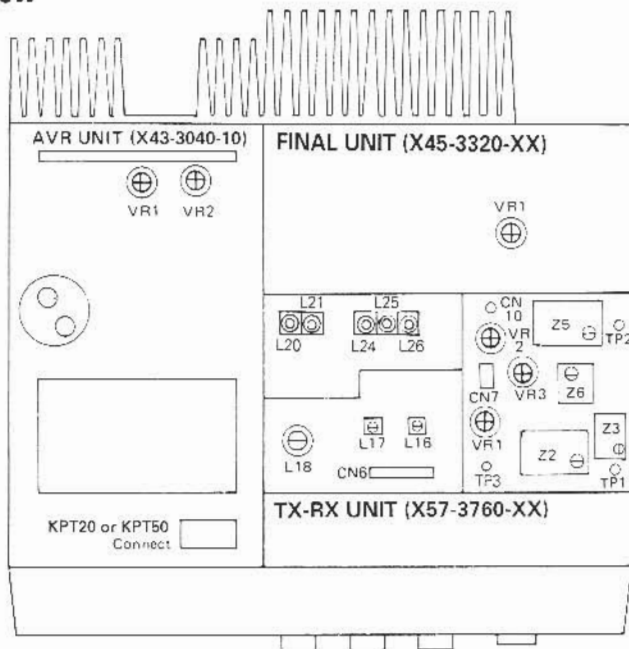

Adjustment points

SIGNALING UNIT (X52-3140-10)

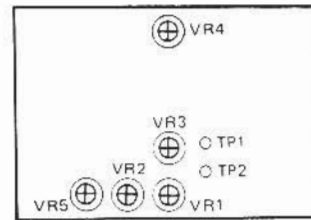

Bottom view

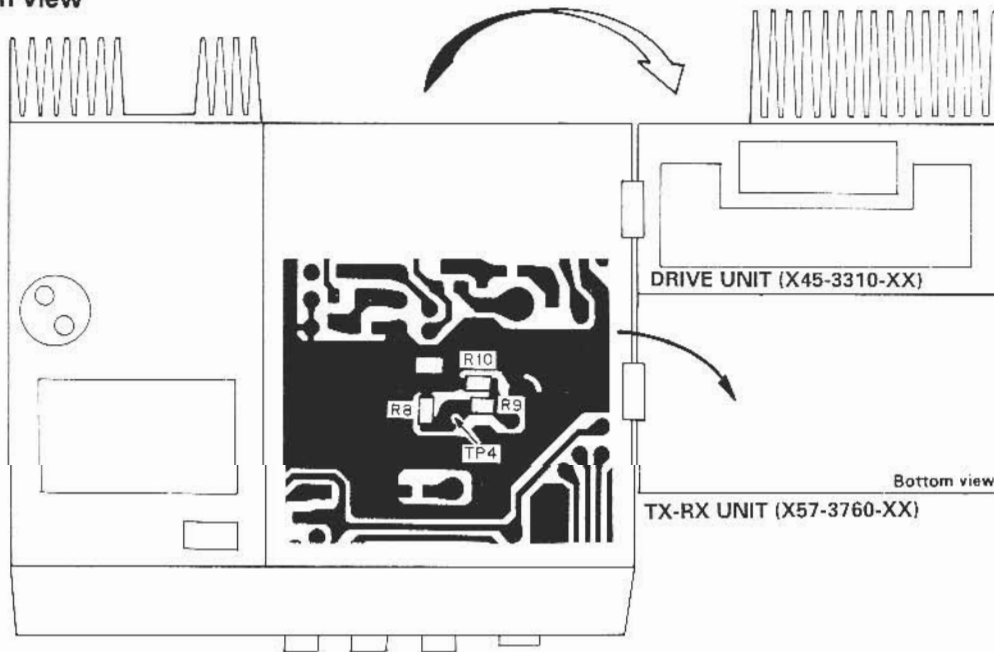

Front panel view

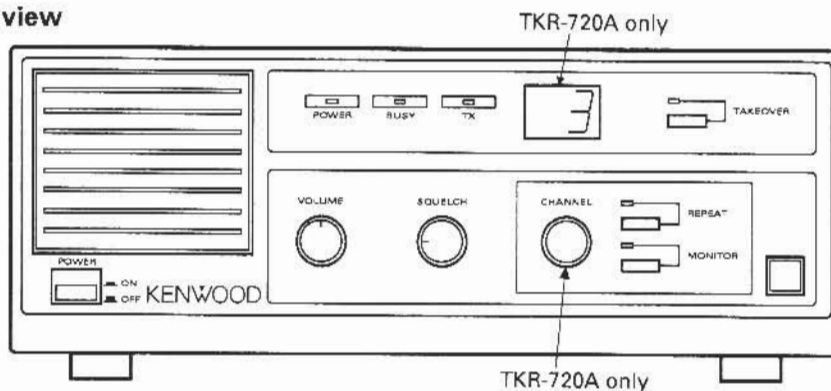

ADJUSTMENT

Alignment

Item	Condition	Measurement			Adjustment			Specifications/Remarks
		Test-equipment	Unit	Terminal	Unit	Parts	Method	
1. Setting	1) AC voltage for destination : 120V K,K2 : 220V M,M2,NM,NM2,AM,AM2 2) Connect to the DC output (OUT terminal) and GND of the AVR unit (*).							
2. Test equipment set-up	1) Function : 0.1Ω resistor Meter : 60A, 60V DC : ON Power : ON SW1 : OFF							
3. Voltage setting	1) Power switch : ON	DVM	AVR	OUT	AVR	VR1	Adjust the load for 10A.	13.6V±0.4V (Verify power indicator lights.)
	2) Vary the load for 2A to 10A draw. (Set to 10A after check.)	DVM AF VTVM					Check	13.6V±0.7V DC K,K2,M,M2,NM,NM2 13.6V±1.3VDC AM,AM2 Less than 30mV AC
	3) Power switch : OFF							
4. Protection	1) SW1 : ON VR2 : MAX CW. Power switch : ON	DVM	AVR	OUT	AVR	VR2	0.25V	±0.05V
	2) SW1 : OFF						Check	13.6V±0.4V
5. Setting	1) Write in frequency designed with EEPROM writer. (For frequency writing, set the power of TKR-720 to ON.) 2) Connect the power cable to the rear panel. 3) Final unit VR1 : MAX CCW. 4) TX-RX unit VR1, VR3 : MAX CCW. 5) Power switch : ON							

ADJUSTMENT

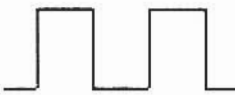
Item	Condition	Measurement			Adjustment			Specifications/Remarks
		Test-equipment	Unit	Terminal	Unit	Parts	Method	
6. RX PLL lock voltage		DVM	TX-RX	TP1	TX-RX	Z2	4.0V	±0.5V
7. TX PLL lock voltage				TP2		Z5	4.0V	±0.5V
8. TCXO frequency adjustment	1) PTT : OFF (RX) Note : TCXO is adjusted precisely at 25°C. If it is readjusted, the frequency stability is changed. Do not touch it normally.	Power meter f. counter	TX-RX	TP4 (Foil side)	TX-RX	Z3	f - 21.4MHz	±100Hz
9. Power adjustment (APC)	1) PTT : ON	Power meter Ammeter	Rear panel	TX ANT	Final	VR1	MAX CW	58W or more
							MIN	15W or less
							50W	±1W
10. Transmit frequency	1) PTT : ON	Power meter f. counter	Rear panel	TX ANT	TX-RX	Z6	Adjust the transmit frequency	±200Hz
11. Tone deviation adjustment	1) QT tone frequency being written. Deviation meter filter LPF : 3kHz HPF : OFF De-emphasis : OFF PTT : ON	Power meter Deviation meter	Rear panel	TX ANT	Signaling	VR4	±0.9kHz K,K2,M, M2,AM,AM2 ±0.45kHz NM,NM2	±100Hz
12. Maximum deviation adjustment	1) Connect AG to the MIC terminal. AG : 1kHz/50mV Deviation meter filter LPF : 20kHz HPF : 50Hz De-emphasis : 750μsec. TX-RX unit VR1 : MAX CW. PTT : ON	AG	Front panel	MIC	TX-RX	VR2	±4.4kHz (±4.9kHz in use of signaling.) K,K2,M, M2,AM,AM2 ±2.2kHz (±2.45kHz in use of signaling.) NM,NM2 Adjust one more than the other by switching between -P and +P.	±200Hz
13. MIC sensitivity adjustment	1) AG : 1kHz/5mV PTT : ON						VR1	
14. DQT waveform correction (For DQT use only)	1) Connect AG to the TX-RX (TP3) and enter a square wave of 100Hz, 2Vp-p. Deviation meter filter : OFF PTT : ON	Power meter Deviation meter Oscilloscope	Rear panel	TX ANT	TX-RX	VR3	Make the demodulation waveform neat.	
		AG	TX-RX	TP3				

ADJUSTMENT

Item	Condition	Measurement			Adjustment			Specifications/Remarks
		Test-equipment	Unit	Terminal	Unit	Parts	Method	
15. RX sensitivity adjustment		AF VTVM 4Ω dummy load	Rear panel	EXT. SP	Front panel	VOL.	0.78V/4Ω (Noise)	
<p style="text-align: center;">TKR-720</p>								
	1) SSG output : 500μV/-53dBm MOD : OFF	AF VTVM Distortion meter 4Ω dummy load	Rear panel	EXT. SP	TX-RX	L20 L21 L24 L25 L26	Reduce noise level using L20, L21, L24, L25 and L26. Decrease the SSG output so that noise level is always 20 to 30dB lower than 0.45V. Repeat 3 to 4 times.	
	2) SSG output : 500μV/-53dBm MOD : 1kHz DEV : 3kHz K,K2,M,M2,AM,AM2 DEV : 1.5kHz NM,NM2	SSG		RX ANT		L18	Adjust for maximum AF output.	
	3) SSG output : 0.32μV/-117dBm				Front panel	L16 L17	Adjust for maximum SINAD.	
	4) SSG output : 500μV/-53dBm				Front panel	VOL.	0.45V/4Ω	
							Check	SINAD 12dB or more.
					Front panel	VOL.	4.0V/4Ω	
							Check	S/N 45dB or more. K,K2,M,M2,AM,AM2 S/N 39dB or more. NM,NM2 Distortion : 5% or less.
16. Squelch	1) SSG output : OFF Rotate SQL VR to a point at which noise disappears.	AF VTVM 4Ω dummy load Oscilloscope	Rear panel	EXT. SP			Check	SQL index angle 8 : 00 ~ 10 : 00
	2) SSG output : 0.2μV/-121dBm	SSG		RX ANT				Squelch should open.
17. Preset squelch adjustment	1) Signaling unit VR1 to VR5 : MAX CCW. SSG output : OFF	SSG	Rear panel	RX ANT			Check	D7 : LED should light.
	2) SSG output : 0.17μV/-124dBm				Signaling	VR1	MAX CW.	D7 : LED should go out.
							Rotate VR1 CCW. to a point at which D7 lights.	

ADJUSTMENT

Item	Condition	Measurement			Adjustment			Specifications/Remarks
		Test-equipment	Unit	Terminal	Unit	Parts	Method	
18. Hangup timer adjustment	1) SSG output : 1.58 μ V/-103dBm The set time can be continuously varied by VR2. 0 ~ 5V \rightarrow 0 ~ 5 sec.	DVM	Signaling	TP2	Signaling	VR2	1.0V	\pm 0.1V
	2) SSG output : 501 μ V/-53dBm REPEAT switch : ON	Power meter SSG	Rear panel	TX ANT RX ANT			Check	TX LED should light. REPEAT LED should light.
	3) SSG output : OFF							TX LED should go out about 1 sec. later after turning SSG OFF.
19. T.O.T	1) The set time can be continuously varied by VR3. 0 ~ 0.3V : OFF ~ 0.5V : 30 sec. ~ 5V : ~ 5 min.	DVM	Signaling	TP1	Signaling	VR3	Set it to the target time.	
20. Repeater TX deviation	1) SSG output : 501 μ V/-53dBm	Power metr Deviation meter SSG	Rear panel	EXT. SP RX ANT	Signaling	VR5	\pm 3.0kHz K,K2,M M2,AM,AM2 \pm 1.5kHz NM,NM2	\pm 100Hz
21. Signaling squelch	1) SSG output : Turn the SSG output so that the SINAD sensitivity becomes 10dB.	<p style="text-align: center;">TKR-720</p>						
	2) SSG MOD SW : EXT. MOD AG1 : 1kHz AG2 : QT tone frequency							
	3) AG1 : Power switch OFF AG2 output : Adjust the output level of AG2 so that the SSG deviation becomes 0.9kHz (K,K2,M,M2,AM,AM2), 0.45kHz (NM,NM2).							
	4) AG1 : Power switch ON AG1 output : Adjust the output level of AG1 so that the SSG deviation becomes 3.9kHz (K,K2,M,M2,AM,AM2), 1.95kHz (NM,NM2). (i.e., QT tone frequency/ 0.9kHz (K,K2,M,M2,AM,AM2), 0.45kHz (NM,NM2) deviation, +1kHz/ 3kHz (K,K2,M,M2,AM,AM2), 1.5kHz (NM,NM2) deviation) MONITOR switch : OFF							
		Rear panel	EXT. SP				Check	Open.
22. TAKEOVER	1) TAKEOVER switch : ON						Check	The TAKEOVER LED should light.

PC BOARD VIEWS/CIRCUIT DIAGRAM TKR-720/N/A

RX PLL : Z1, TX PLL : Z4 (X58-3140-XX) -10 : K,M,AM,K2,M2,AM2 -51 : NM,NM2

RX PLL, TX PLL (X58-3140-XX)

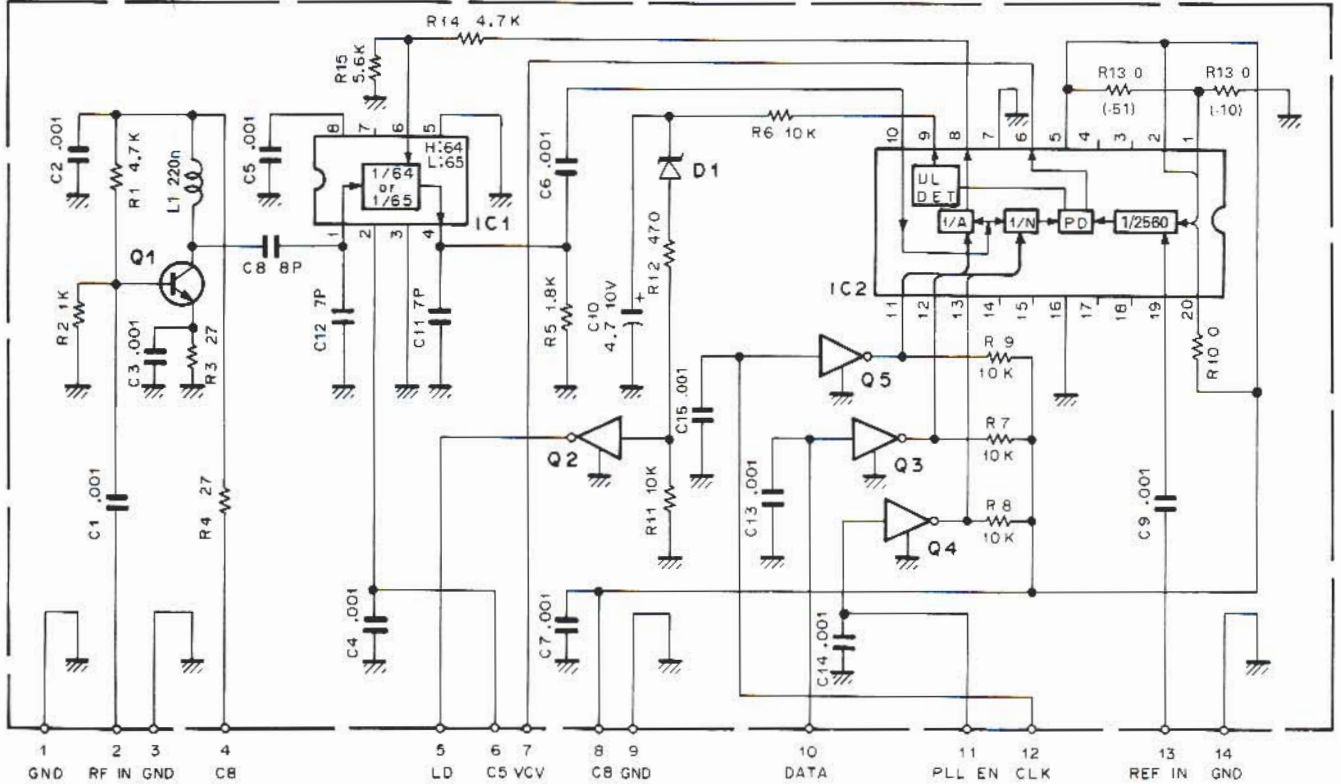

Q1 : 2SC2714(Y) IC1 : MB504F D1 : RD3.0M(B2)
 Q2-5 : DTC114EK IC2 : JLC1075F or JLC1075DW

Component side view

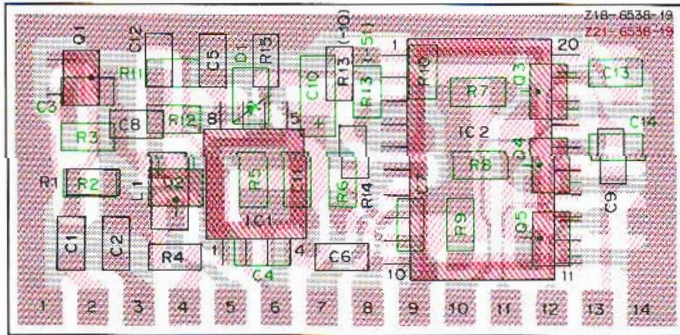

Foil side view

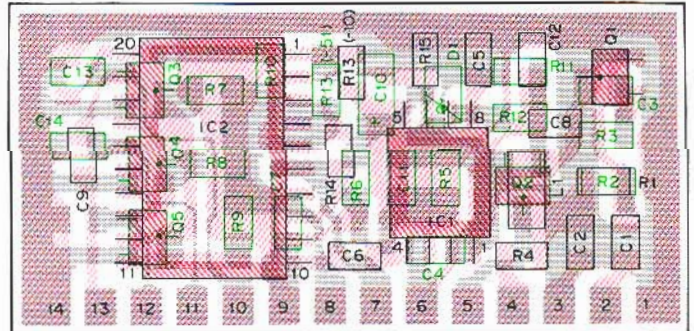

JLC1075F

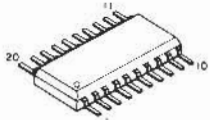

2SC2714
DTC114EK



MB504F

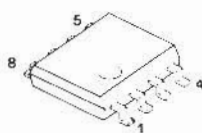

□ : Component side
 ▨ : Foil side

TKR-720/N/A

PC BOARD VIEWS/CIRCUIT DIAGRAM

RX VCO : Z2 (X58-3290-XX) -10 : K,M,NM,AM -11 : K2,M2,NM2,AM2

RX VCO (X58-3290-XX)

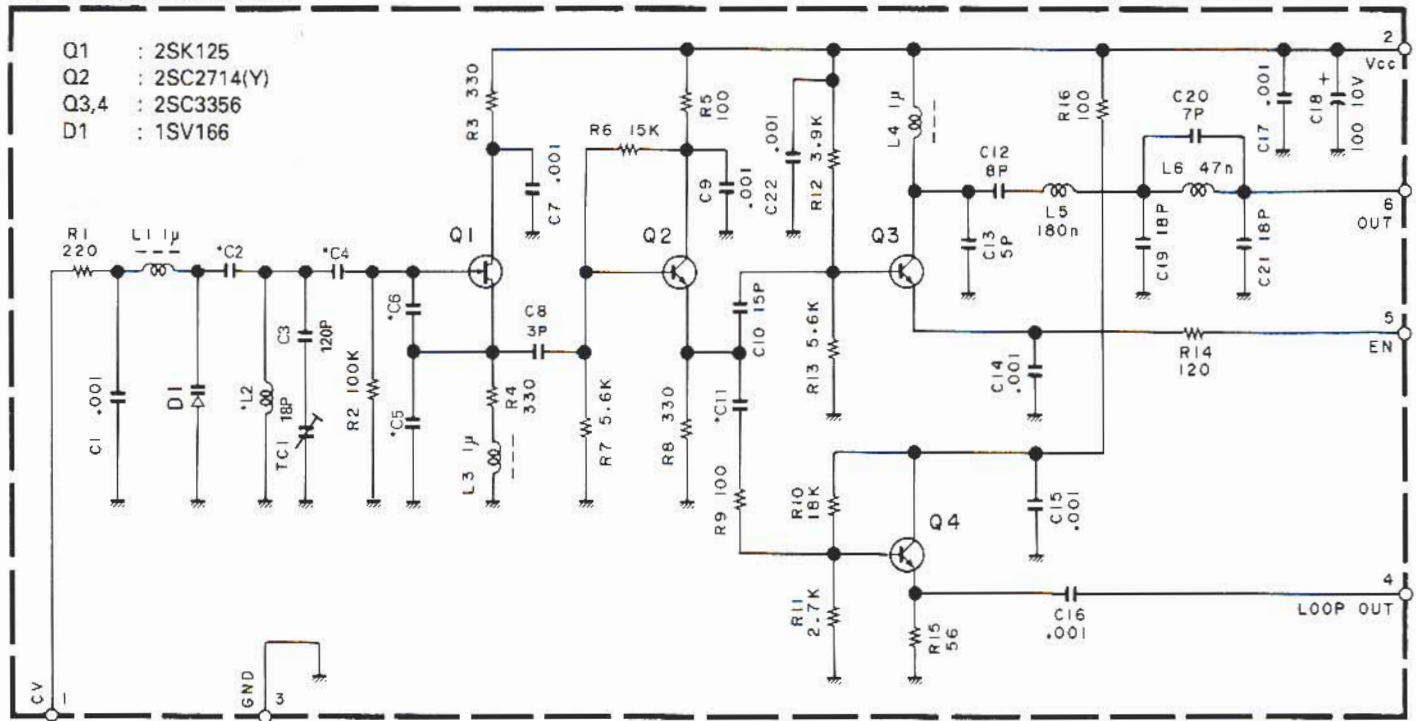

UNITS	C2	C4	C5	C6	C11	L2
X58-3290-10	27P	15P	6P	10P	1P	L34-2309-05
X58-3290-11	22P	18P	9P	15P	3P	L32-0658-05

Component side view

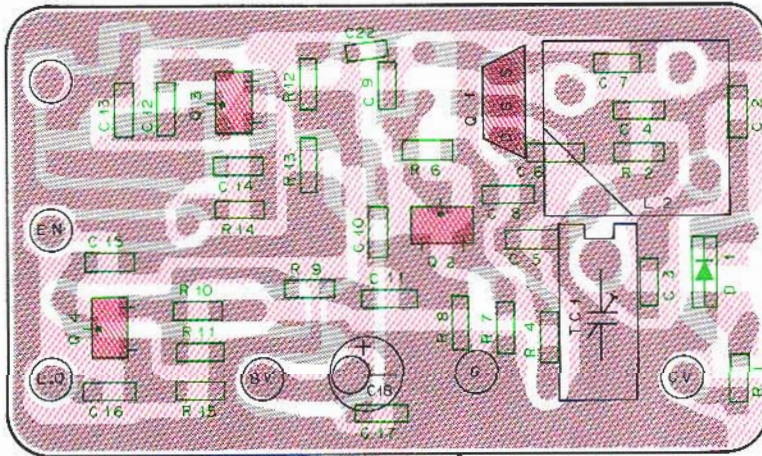

2SK125

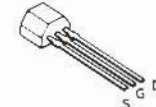

2SC2714
2SC3356



Foil side view

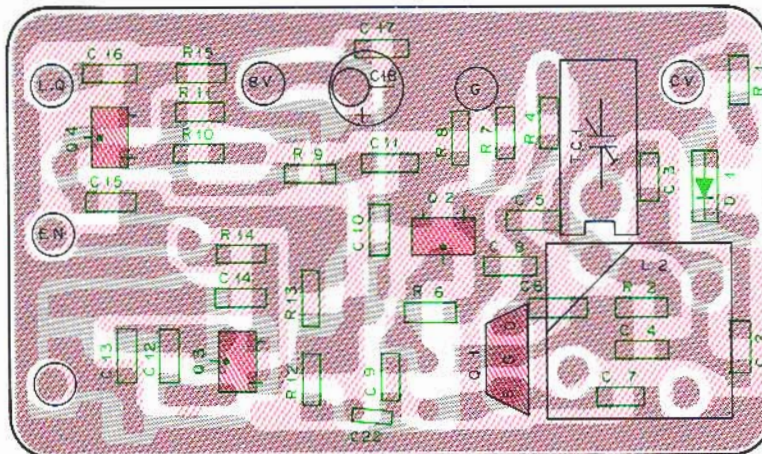

Component side
 Foil side

PC BOARD VIEWS/CIRCUIT DIAGRAM

TKR-720/N/A

TX VCO : Z5 (X58-3790-XX) -10 : K,M,NM,AM -11 : K2,M2,NM2,AM2
 TX VCO (X58-3790-XX)

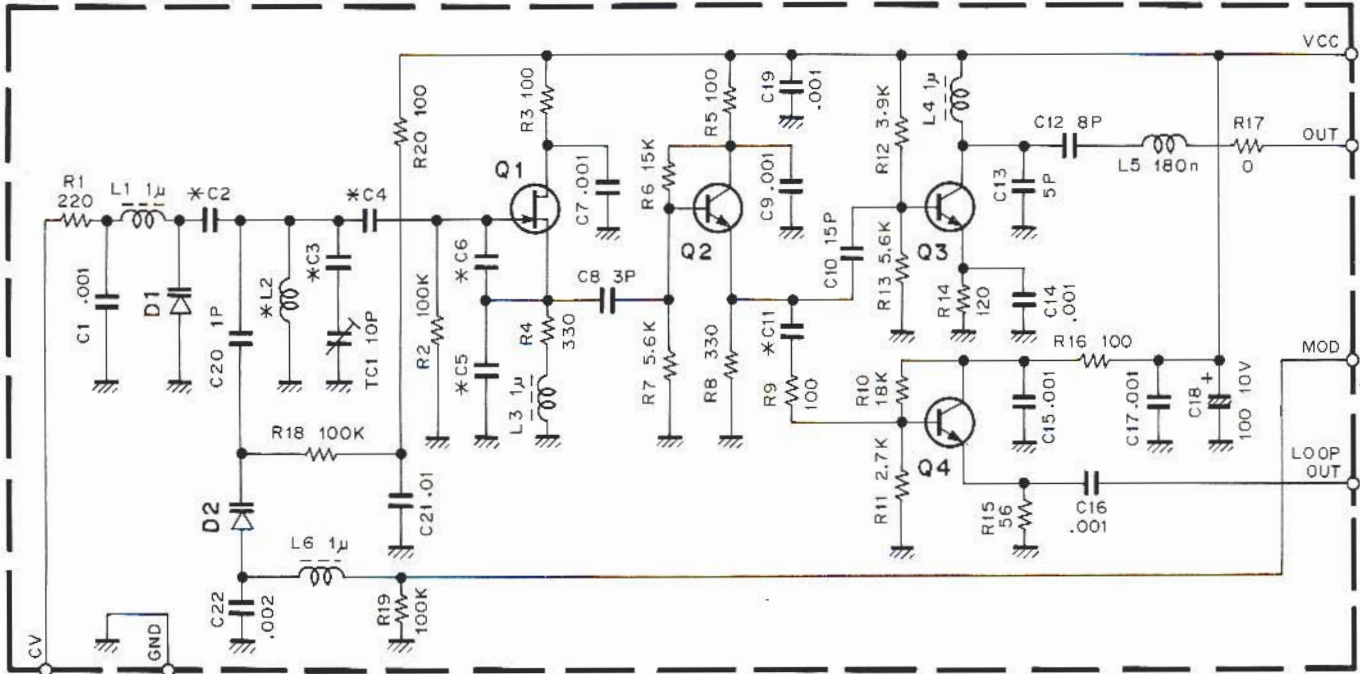

- Q1 : 2SK125
- Q2 : 2SC2714(Y)
- Q3,4 : 2SC3356
- D1 : 15V166
- D2 : 15V164

	C2	C3	C4	C5	C6	C11	L2
-10	18P	56P	9P	4P	6P	1P	L34-2309-05
-11	15P	47P	12P	6P	10P	3P	L32-0658-05

Component side view

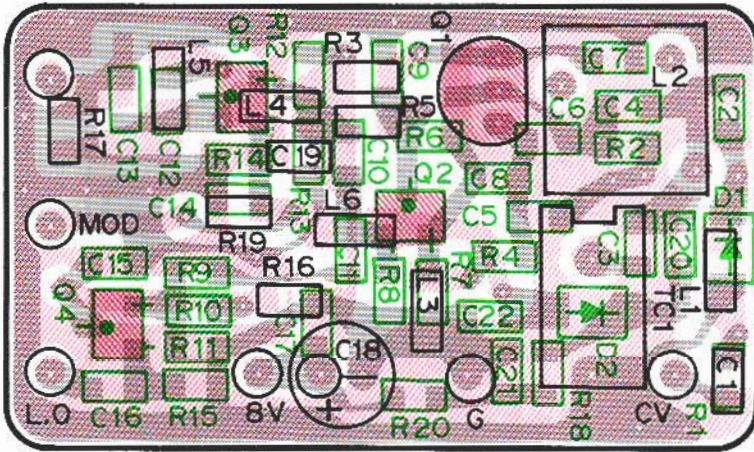

Foil side view

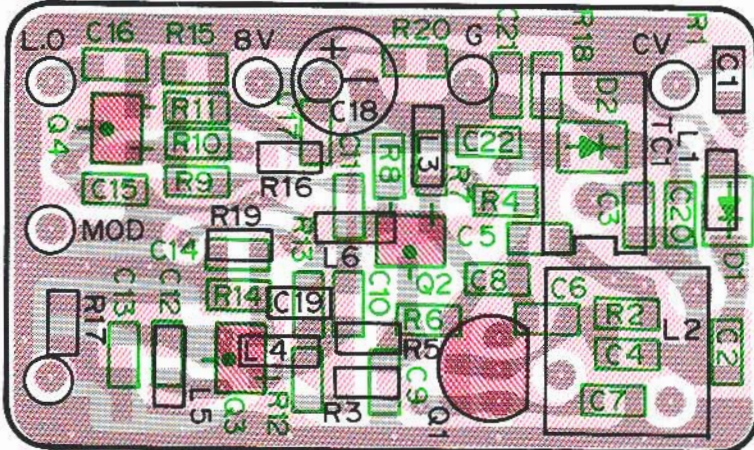

: Component side
 : Foil side

MIC AMP : Z7 (X59-3210-10)

MIC AMP UNIT (X59-3210-10)

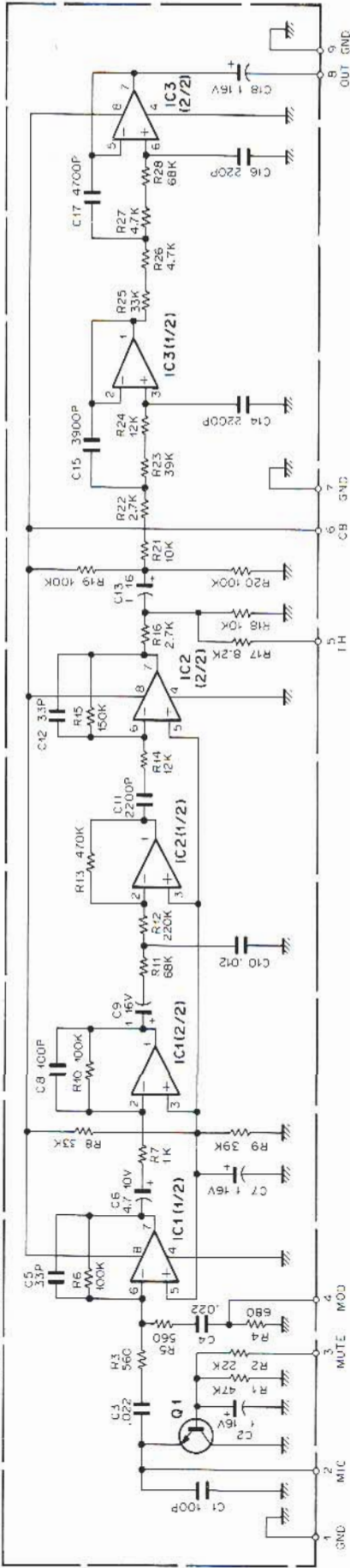

Q1 : 25C3326(A) IC1 : NJM4560M IC2,3 : NJM4558M

Component side view

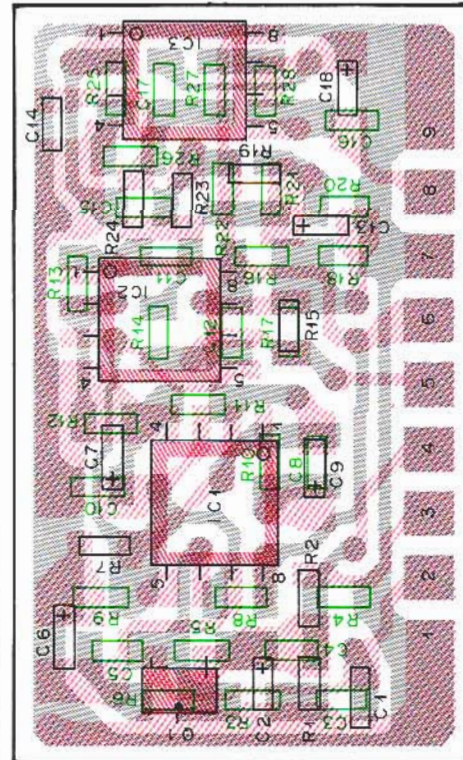

Foil side view

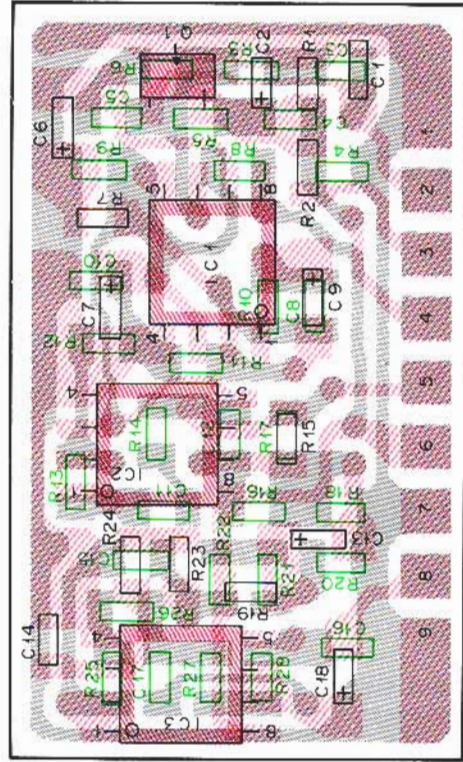

Component side
Foil side

IF : Z8 (X59-3220-10)

IF UNIT (X59-3220-10)

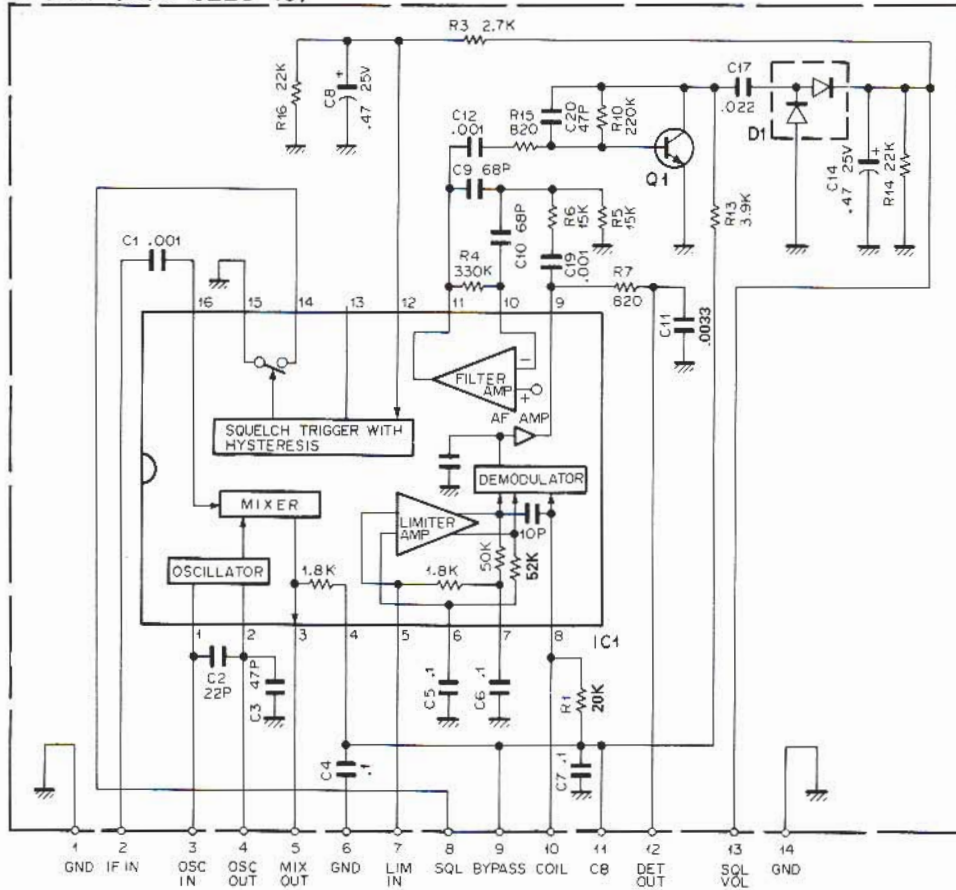

IC1 : MC3361BD
 Q1 : 2SC2712 (Y)
 D1 : DA204K

Component side view

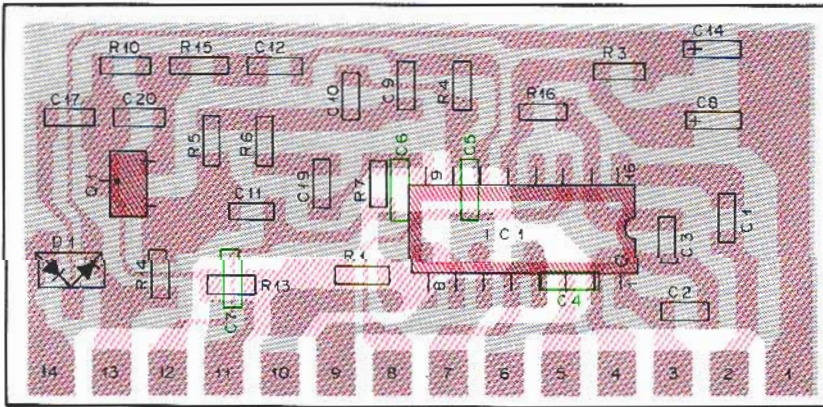

2SC2712
 2SC3326

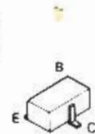

MC3361BD

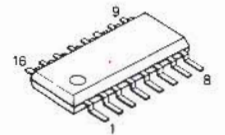

Foil side view

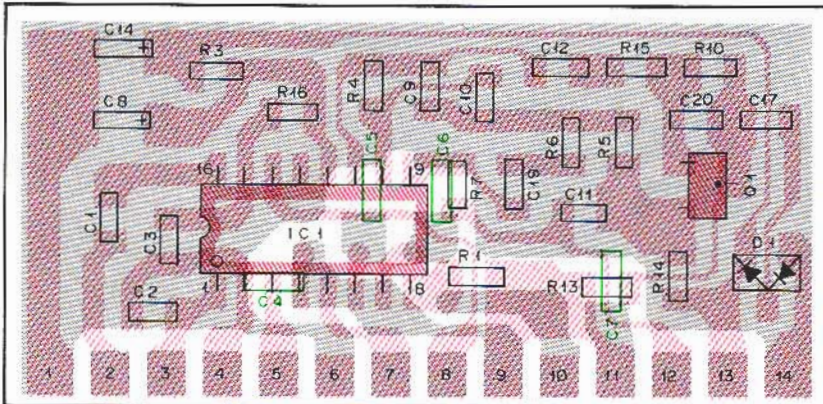

M5222FP
 NJM4558M
 NJM4560M

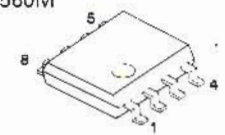

Component side
 Foil side

BPF/VCA : Z9 (X59-3230-10)

BPF/VCA (TX-RX UNIT : Z9) (X59-3230-10)

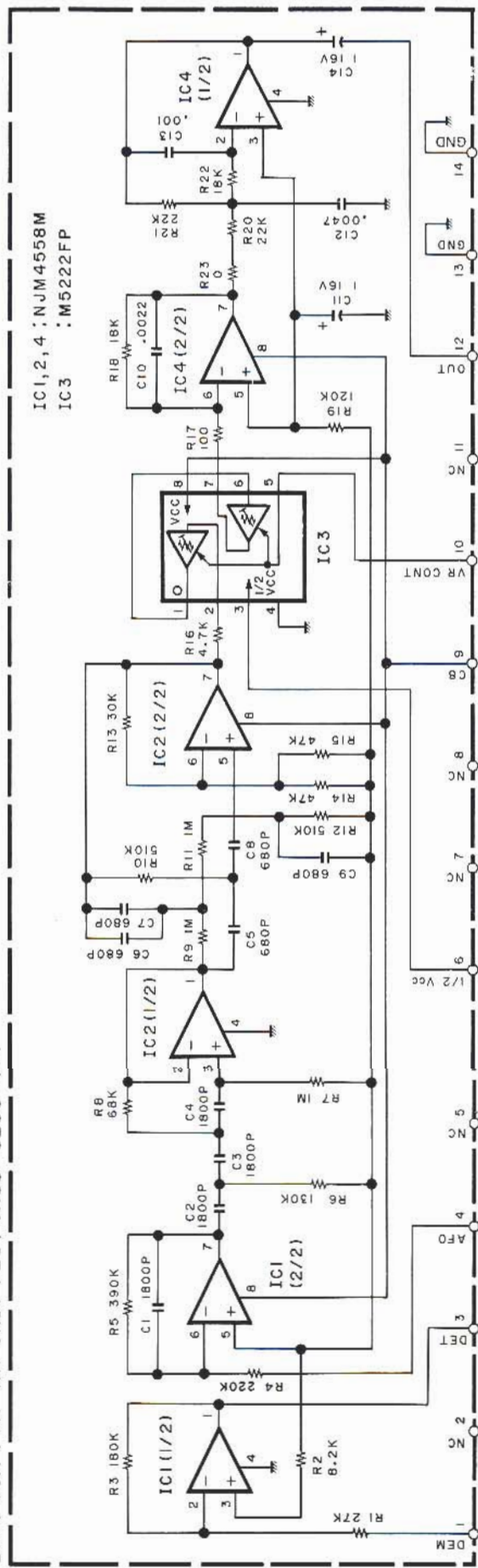

Component side view

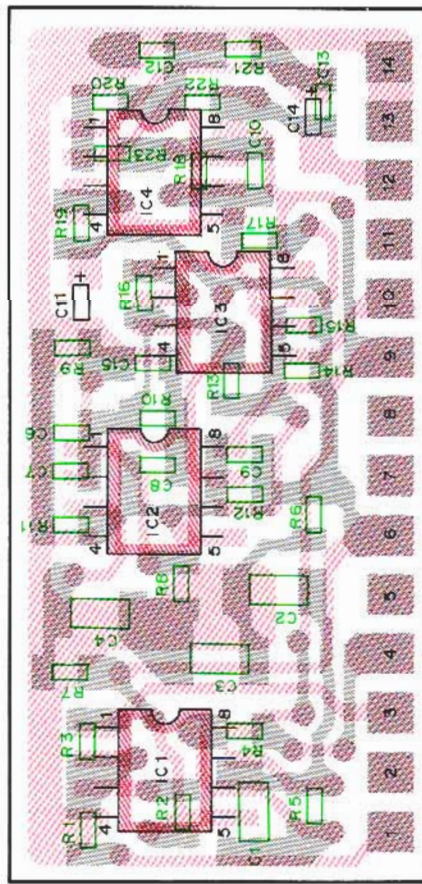

Foil side view

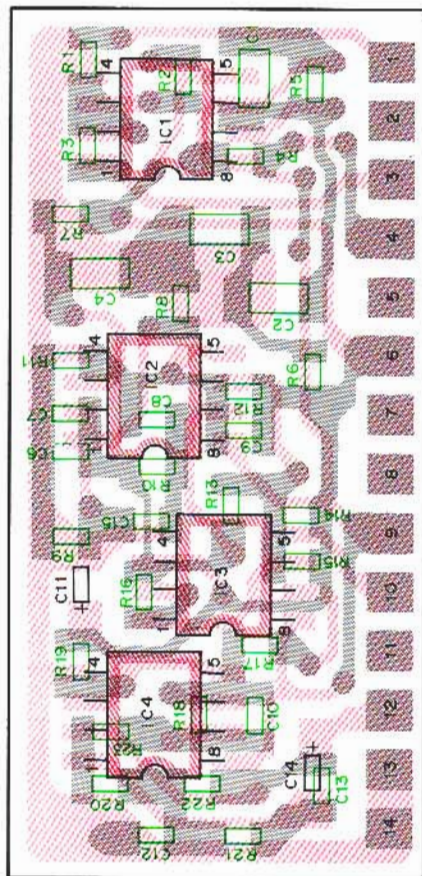

Component side
Foil side

TKR-720/N/A CIRCUIT DIAGRAM

SIGNALING UNIT (X52-3140-10)

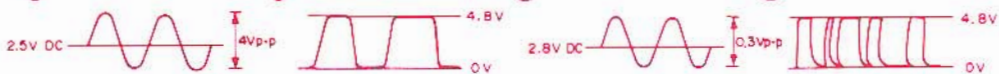
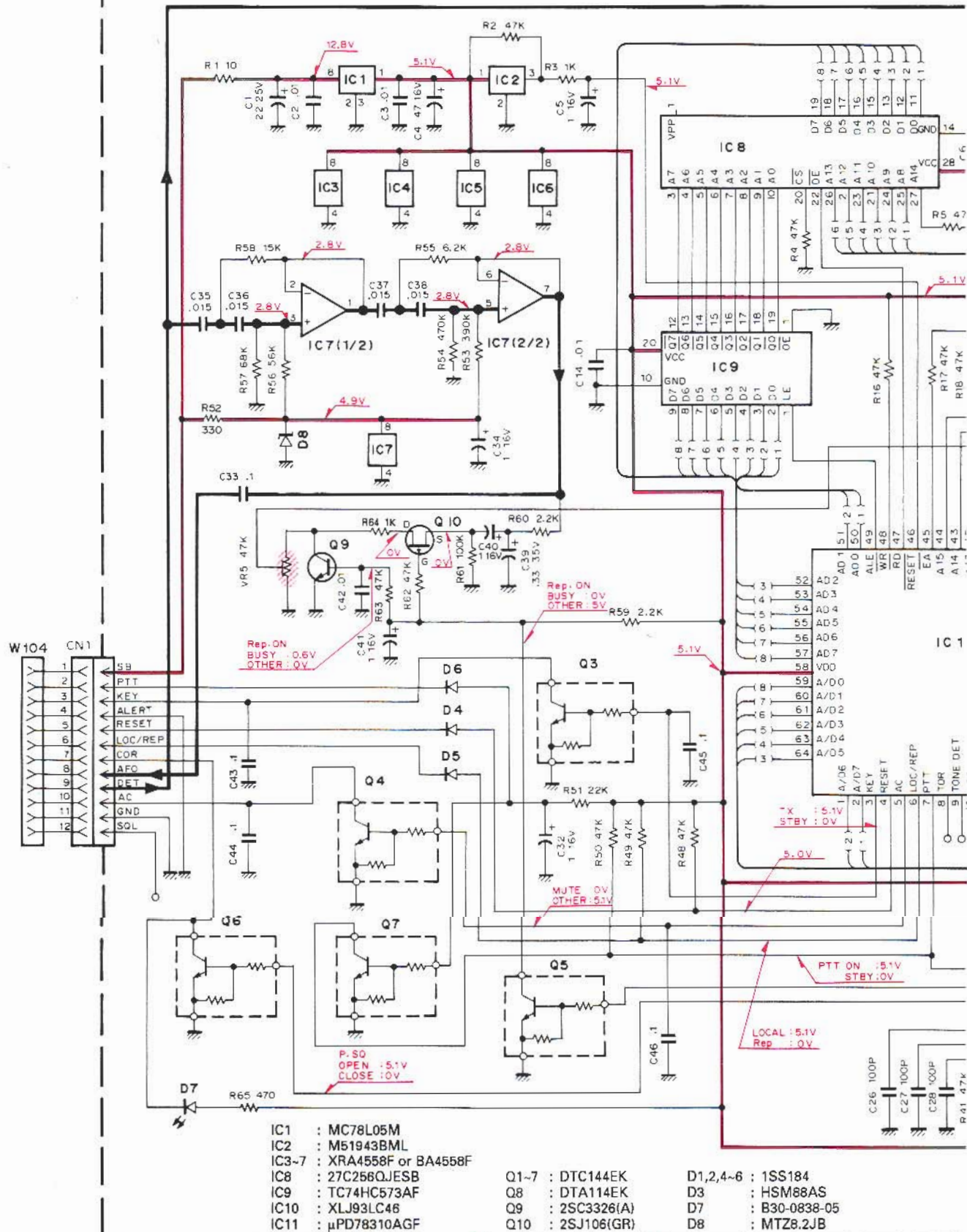

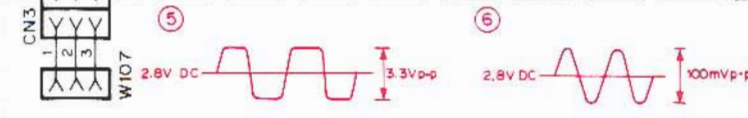
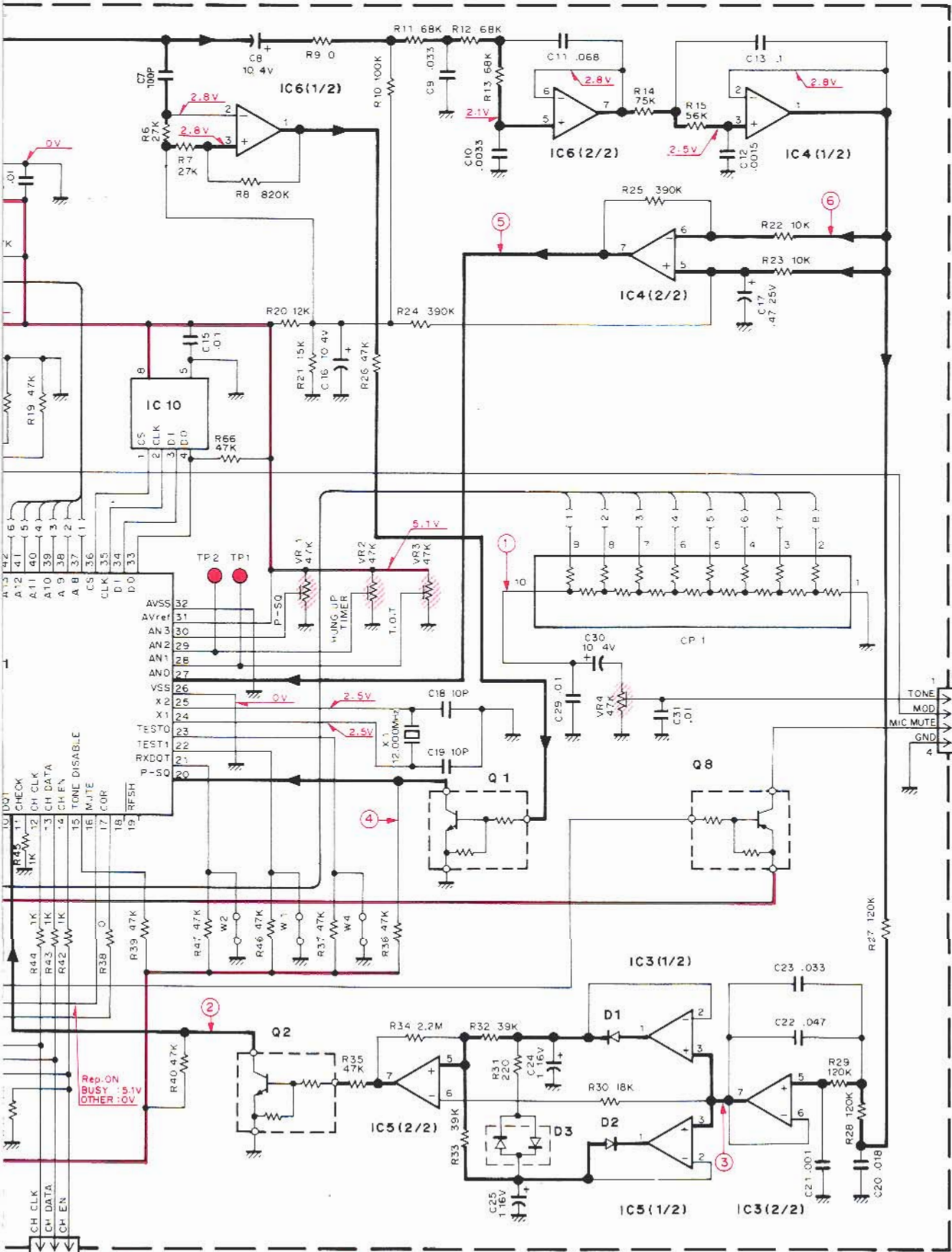

PC BOARD VIEWS TKR-720/N/A

SIGNALING UNIT (X52-3140-10) Component side view

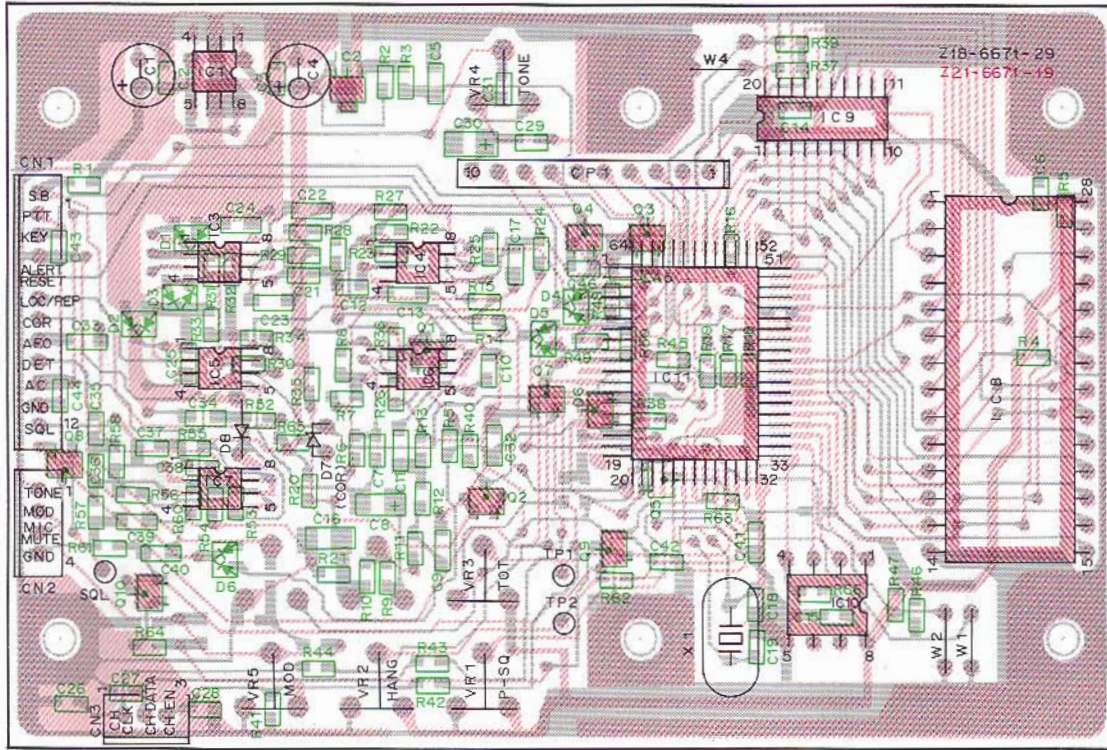

2SC3326
DTA114EK
DTC144EK

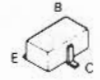

2SJ106

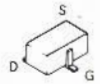

M51943BML

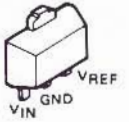

XRA4558F
MC78L05M

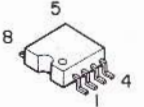

Foil side view

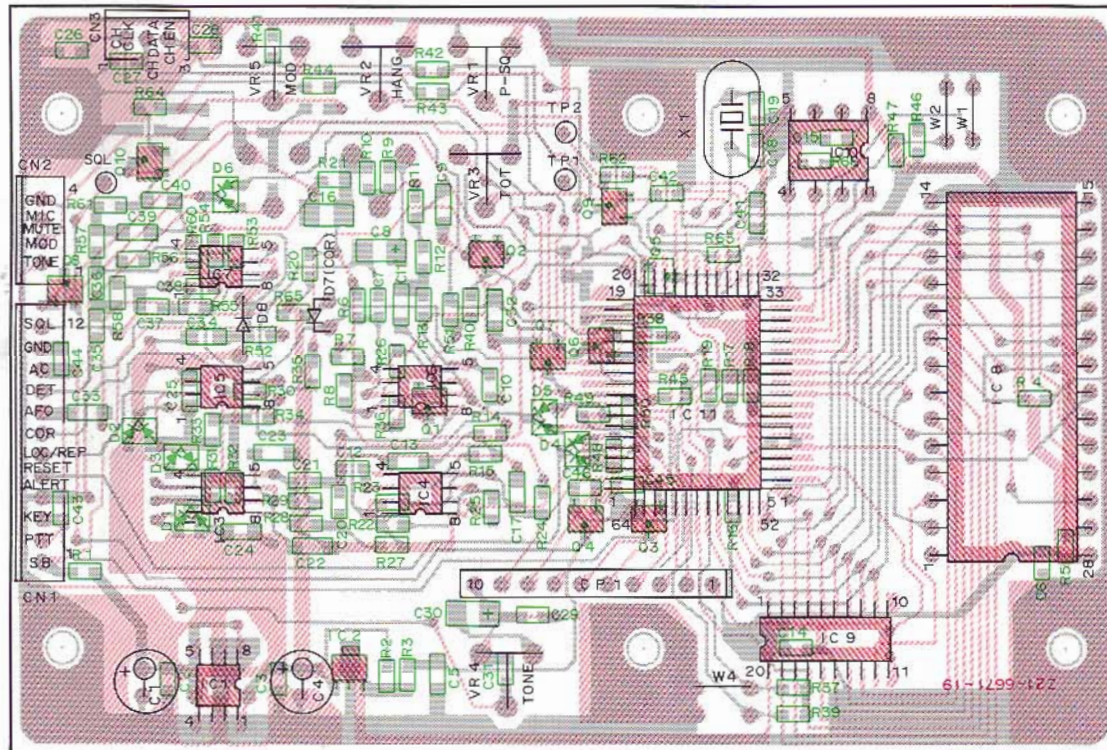

XLJ93LC46

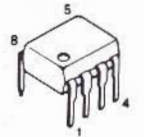

TC74HC573AF

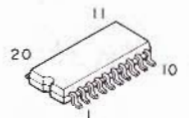

27C256QJESB

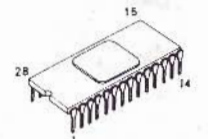

μPD78310AGF

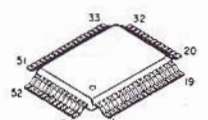

Component side
Foil side

TKR-720/N/A

PC BOARD VIEWS

AVR UNIT (X43-3040-10) Component side view

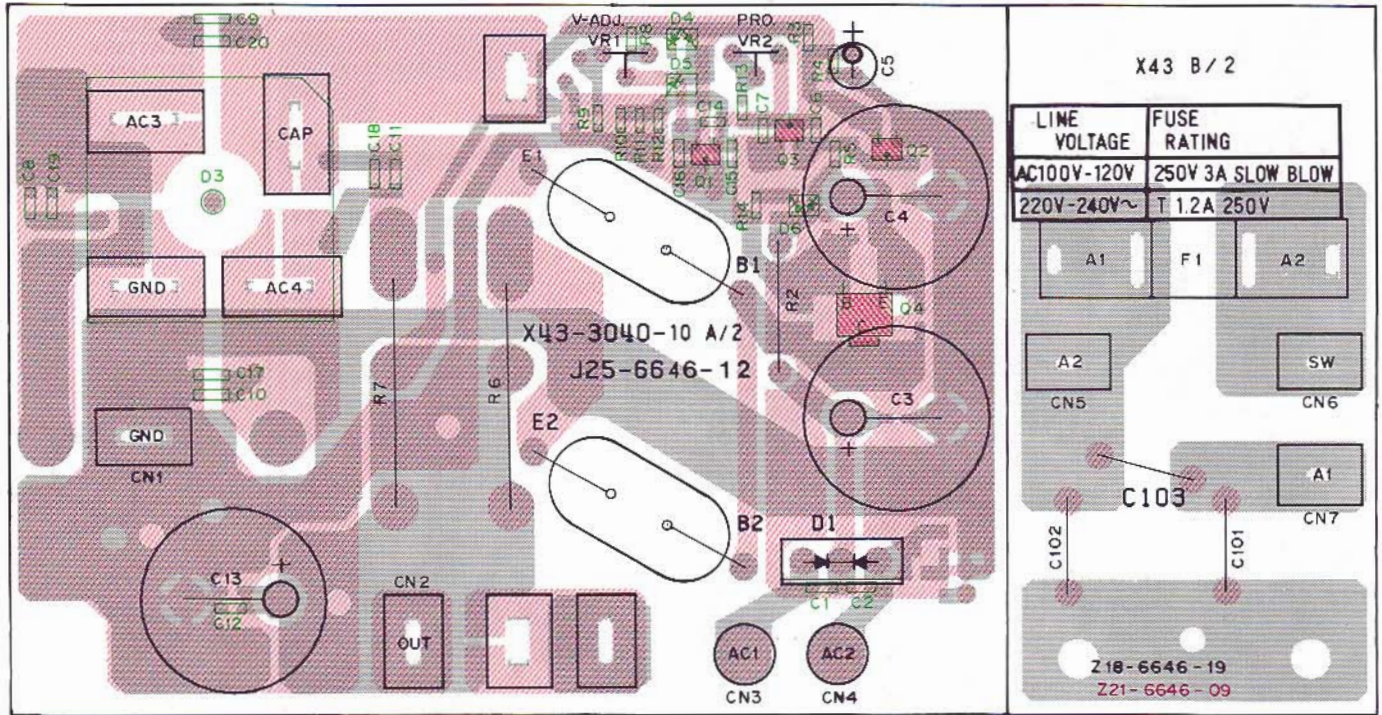

Foil side view

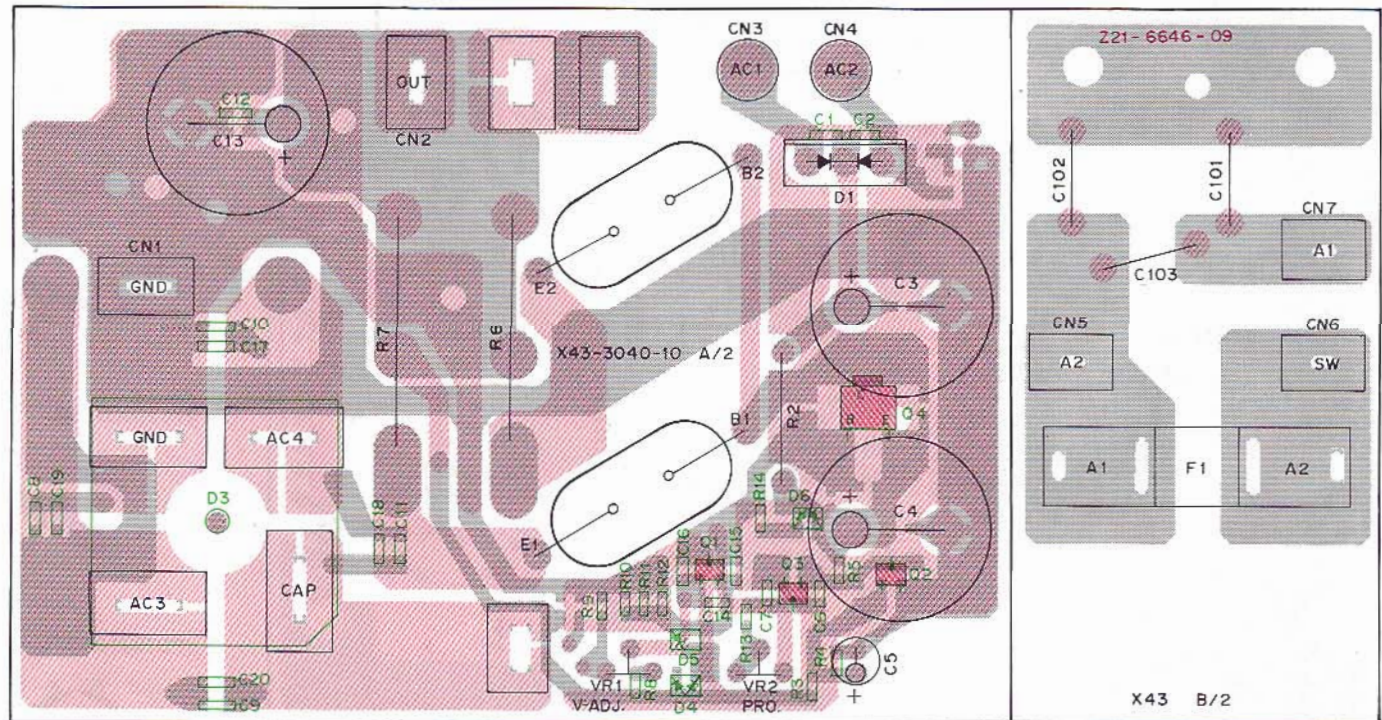

2SB968

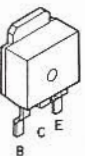

2SC2712



2N5885

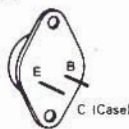

■ : Component side
■ : Foil side

PC BOARD VIEWS TKR-720/N/A

DRIVE UNIT (X45-3310-XX) Component side view

-10 : K,M,AM,NM -11 : K2,M2,AM2,NM2

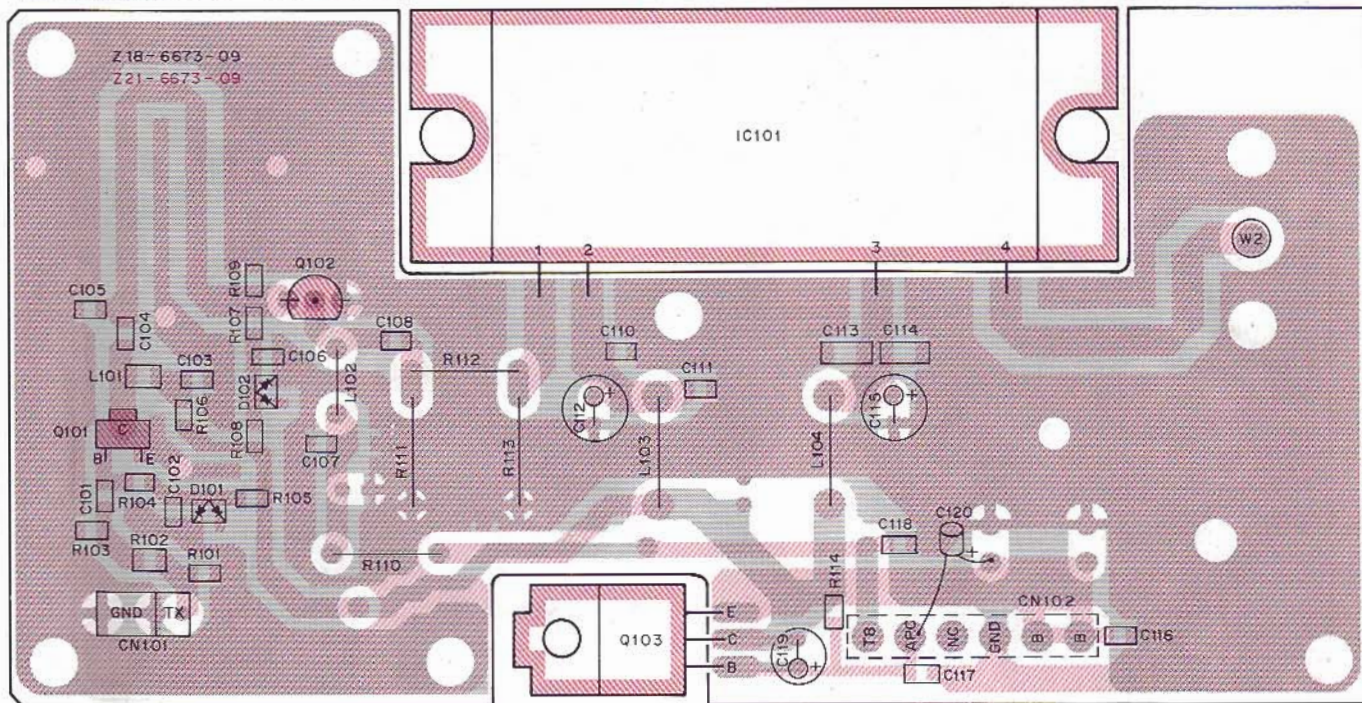

Foil side view

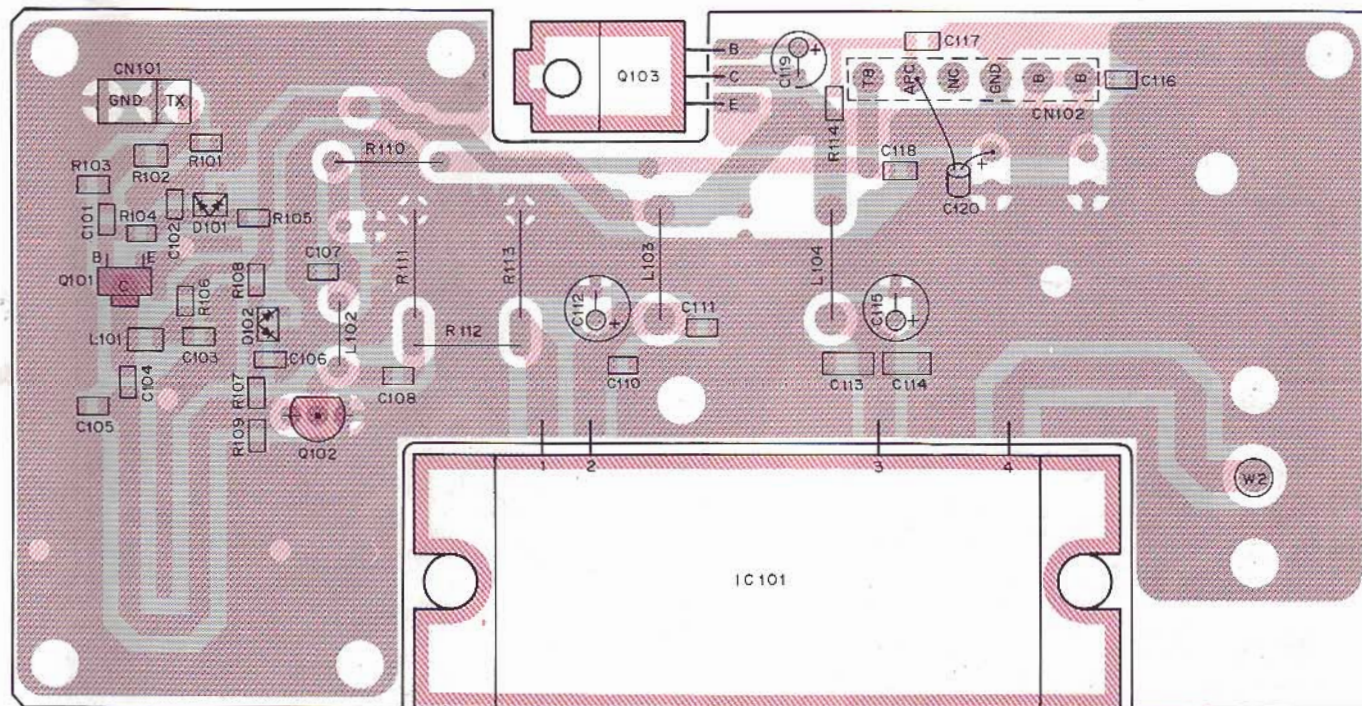

Component side
Foil side

2SC2538-22-A

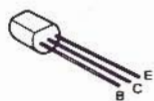

2SB951A



2SC2954

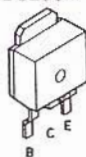

M57719
M57719L-24



TKR-720/N/A

PC BOARD VIEWS

FINAL UNIT (X45-3320-XX) Component side view
 -11 : K,M,AM,NM -12 : K2,M2,AM2,NM2

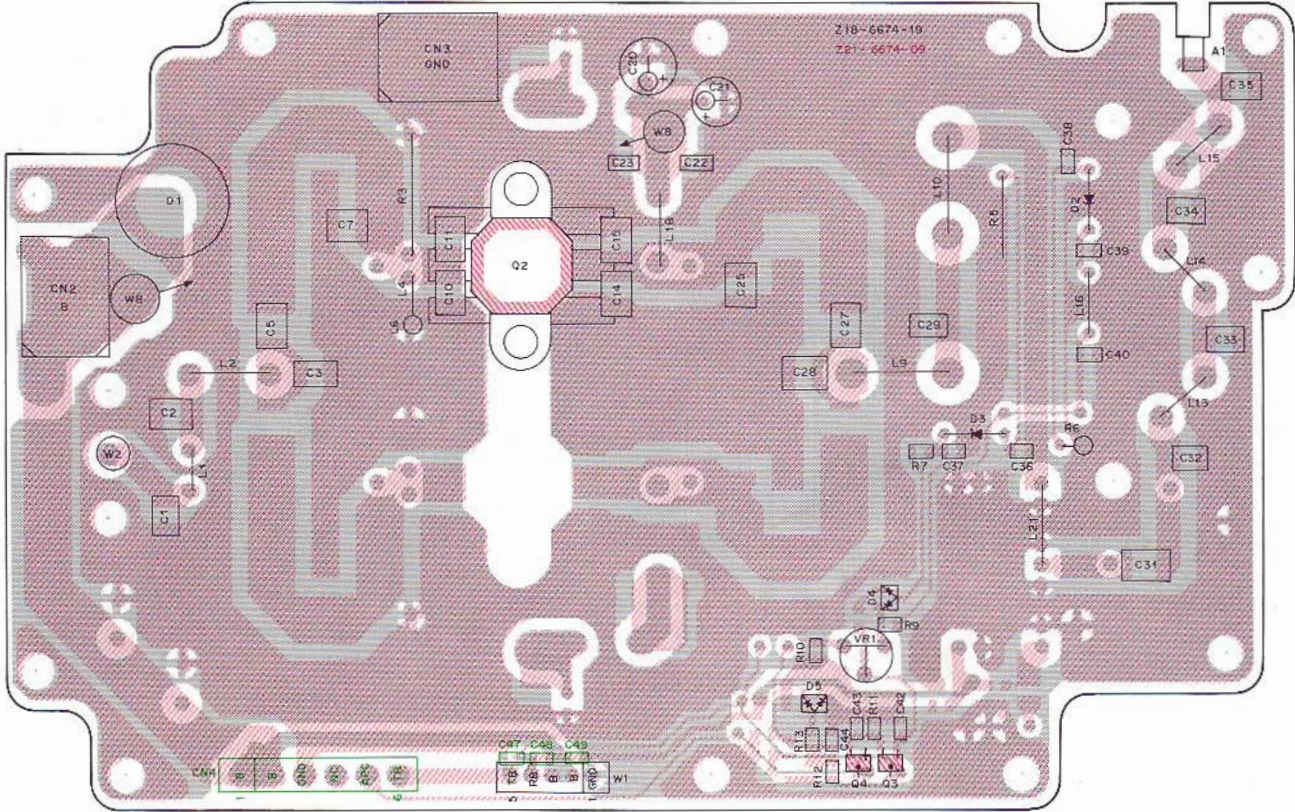

Foil side view

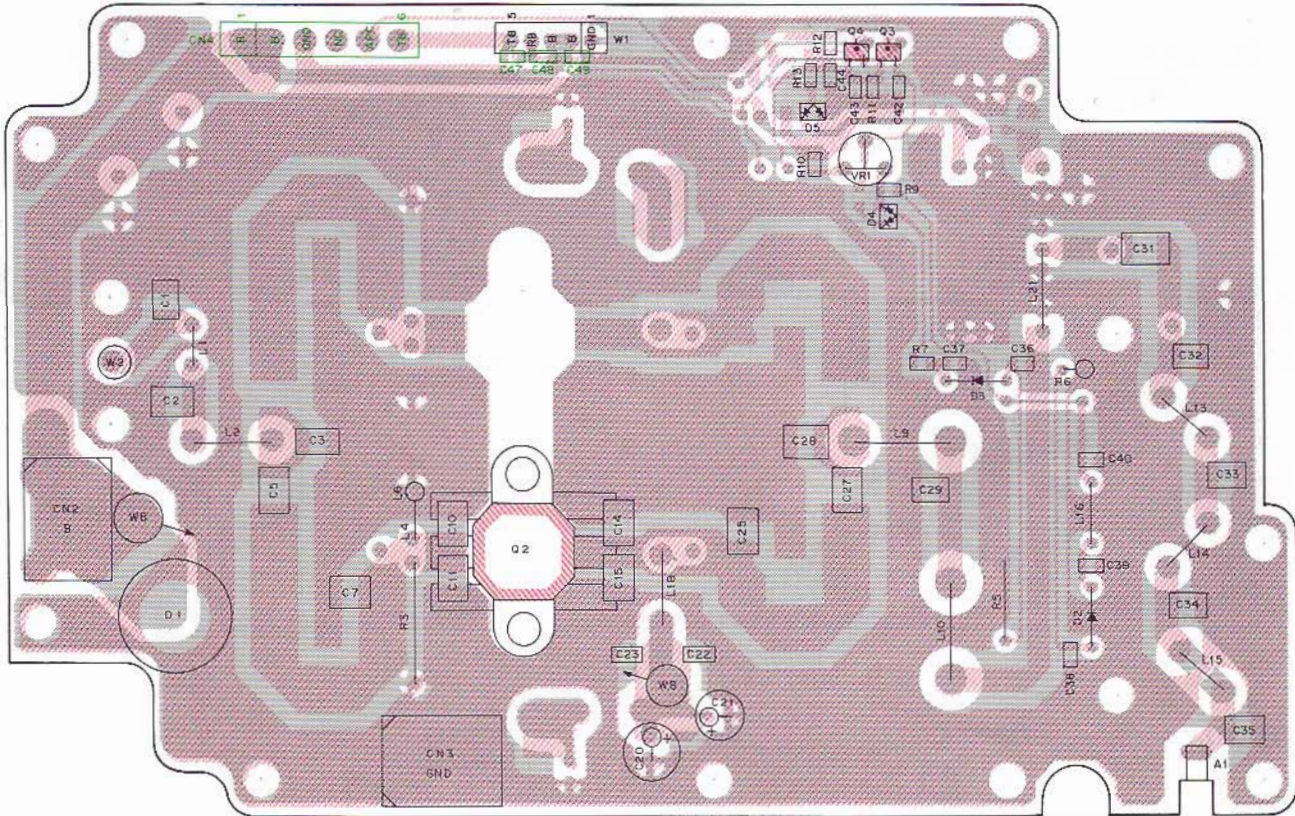

: Component side
 : Foil side

DISPLAY UNIT (X54-3070-XX) Component side view
 -12 : K,K2,M,M2,NM,NM2 -14 : AM,AM2

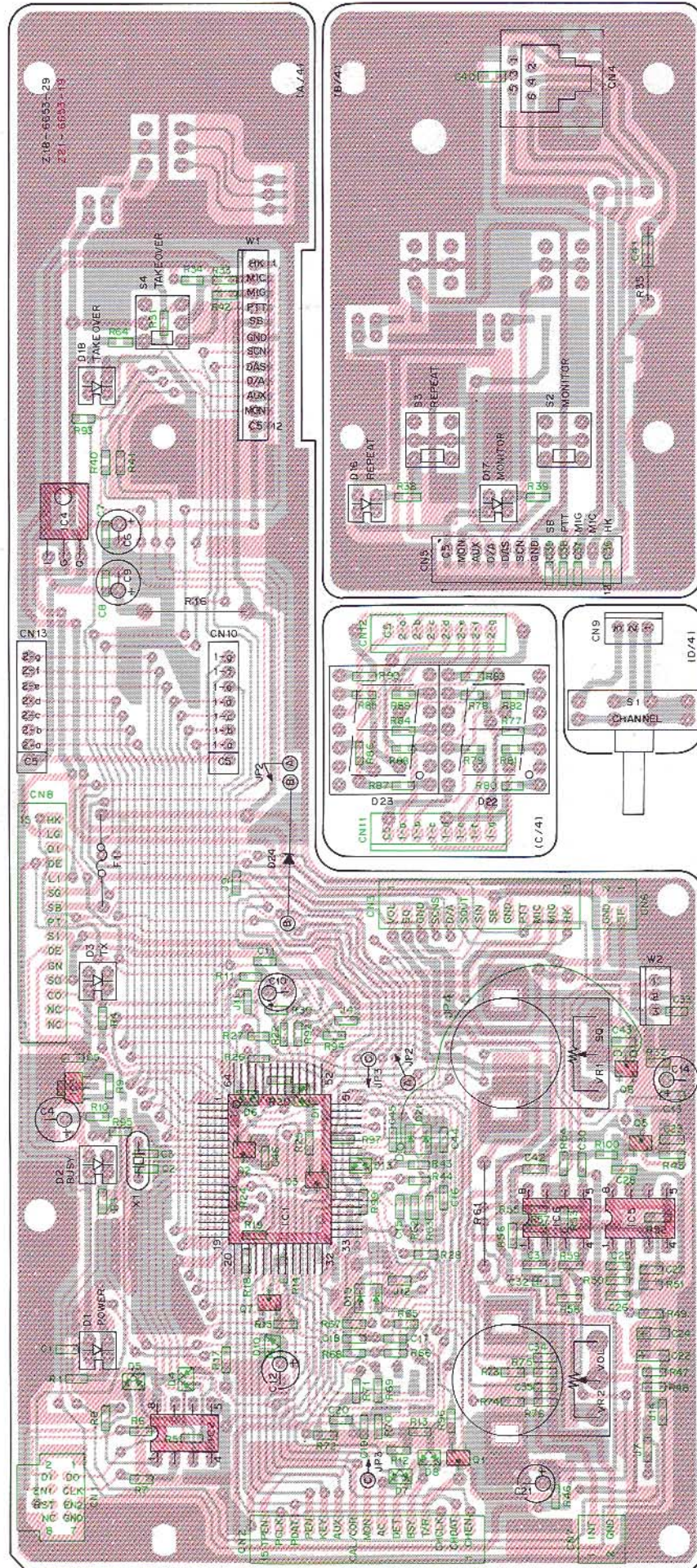

PC BOARD VIEWS TKR-720/N/A

Foil side view

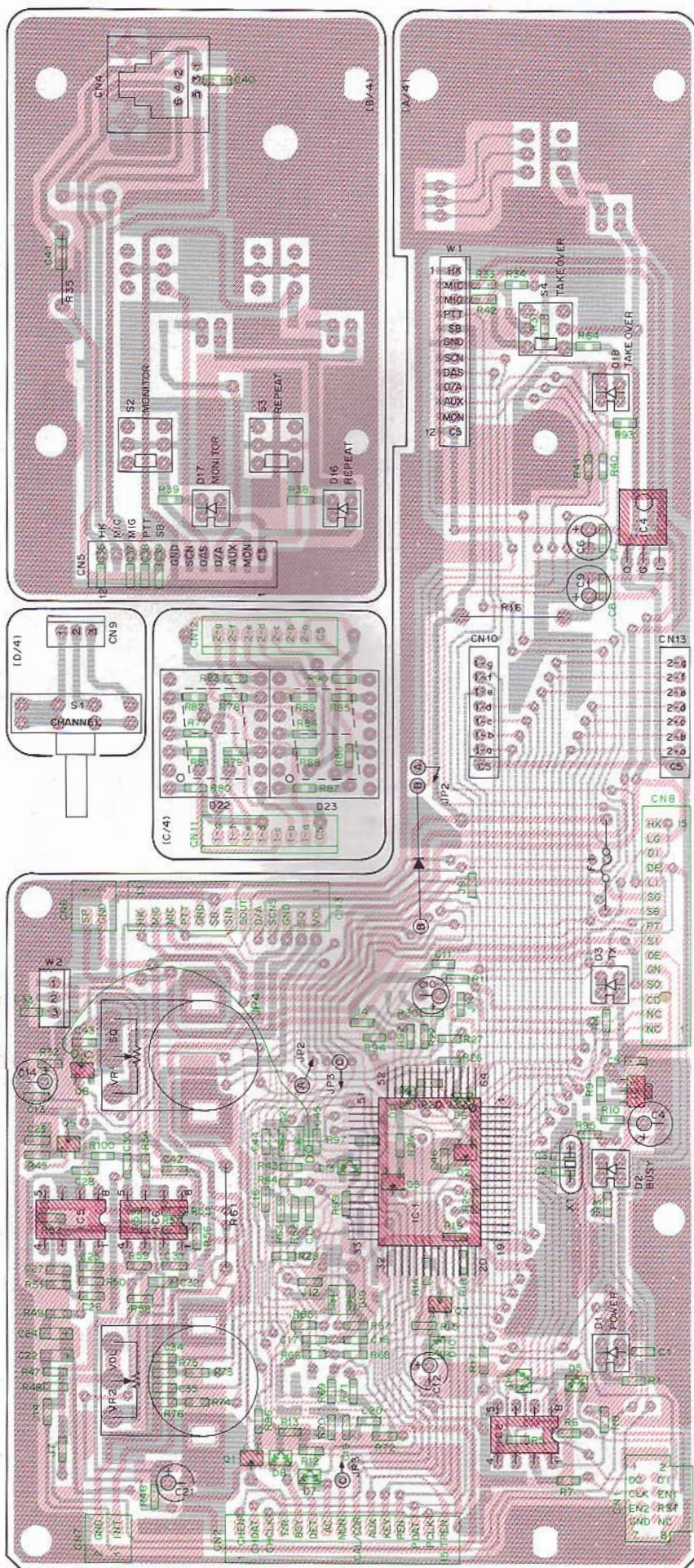

2SA1162
2SC3326
DTC114EK



AN78N05



M51943BML

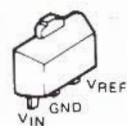

XLJ93LC46

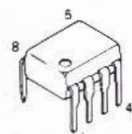

μPC4558C

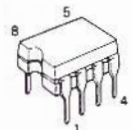

75104G-604-1B

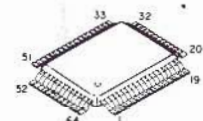

2SC2694

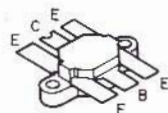

Component side
Foil side

TKR-720/N/A PC BOARD VIEWS

TX-RX UNIT (X57-3760-XX) Component side view
 -10 : K,M,AM -11 : K2,M2,AM2 -12 : NM -13 : NM2

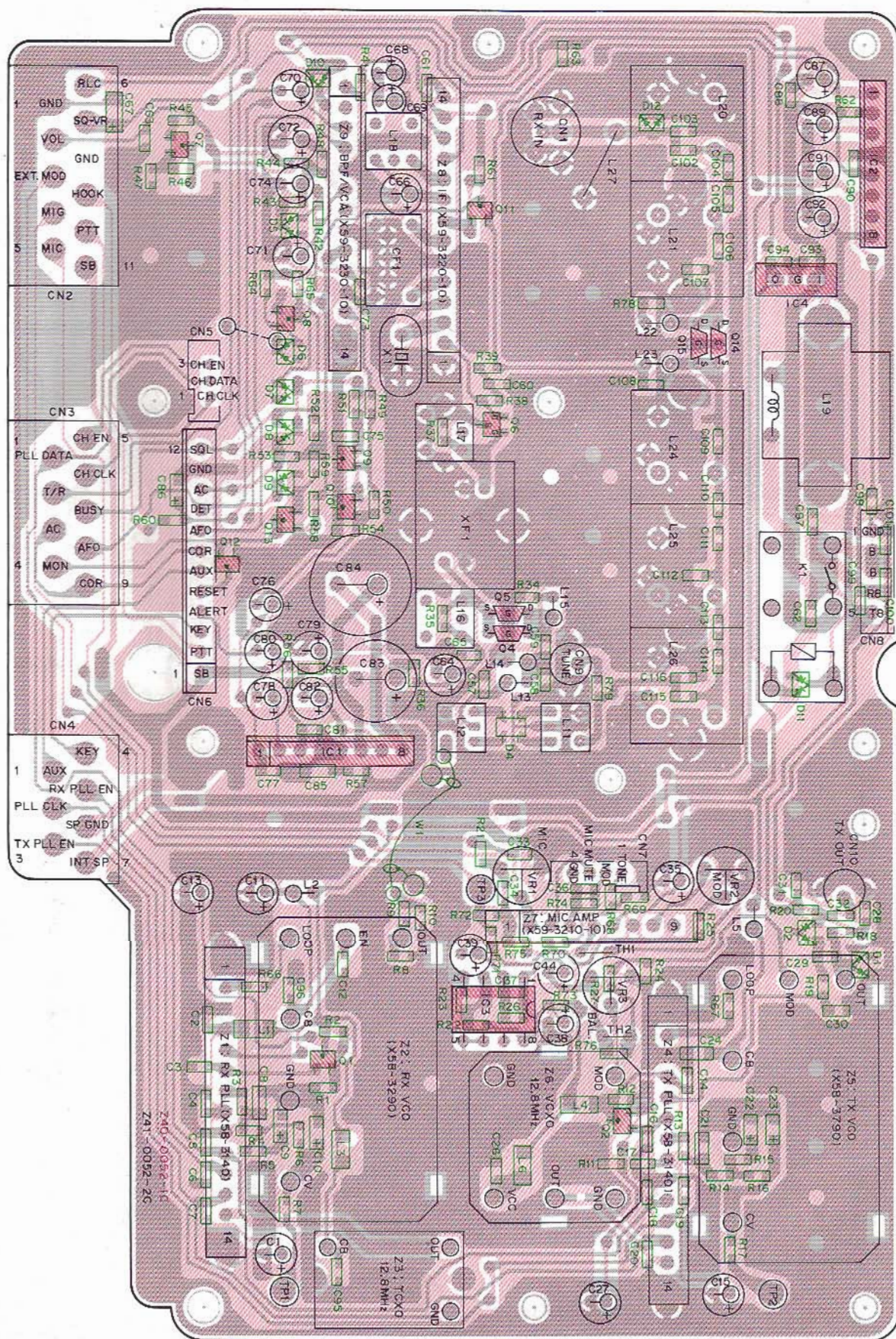

Foil side view

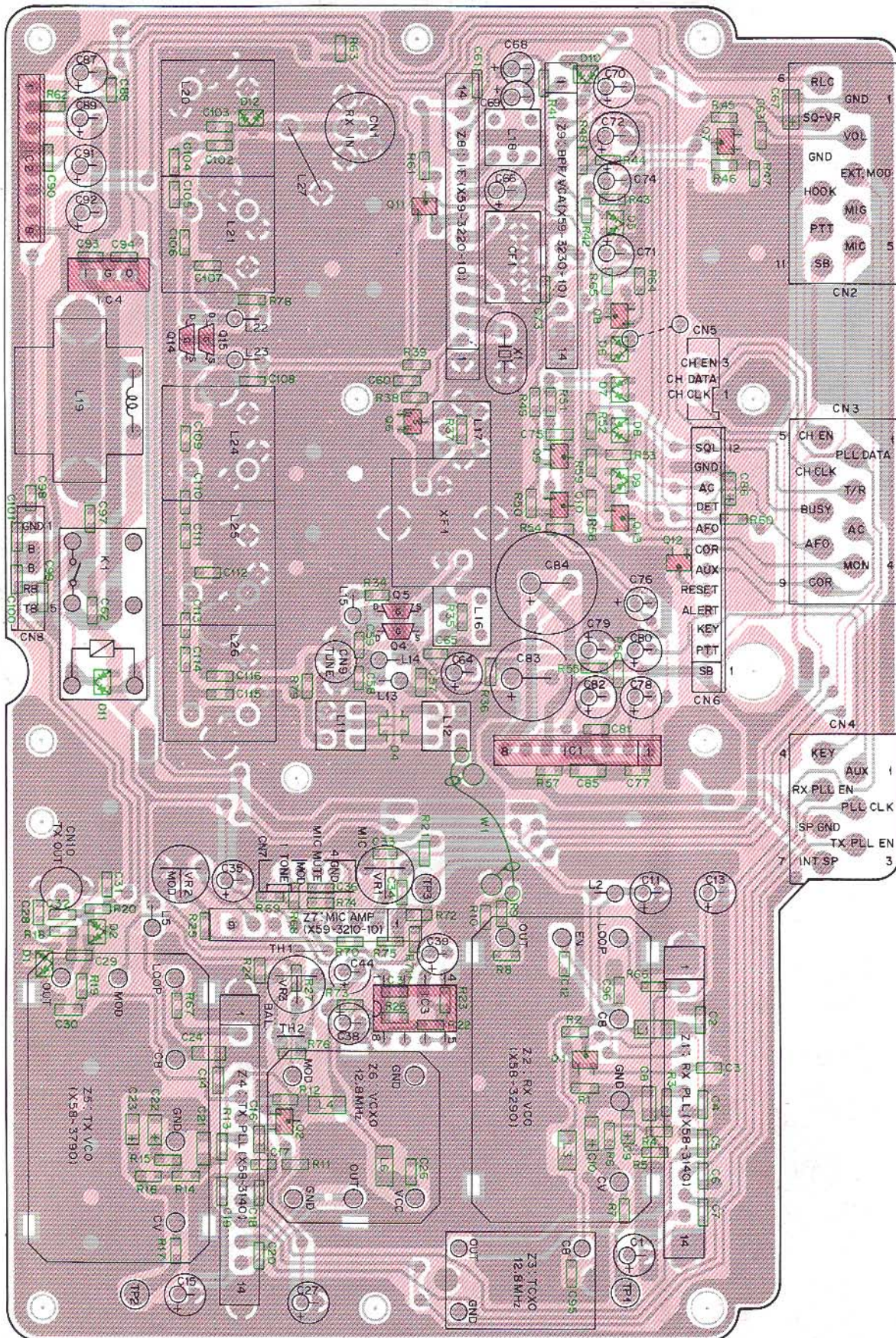

25C2712
25C3326
DTC114EK



L78N08

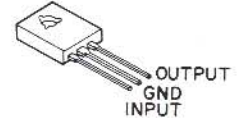

25K302

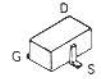

NJM4558D

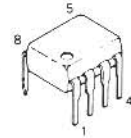

MB3756
μPC1242H



25K125

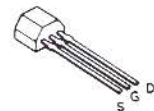

▨ : Component side
▧ : Foil side

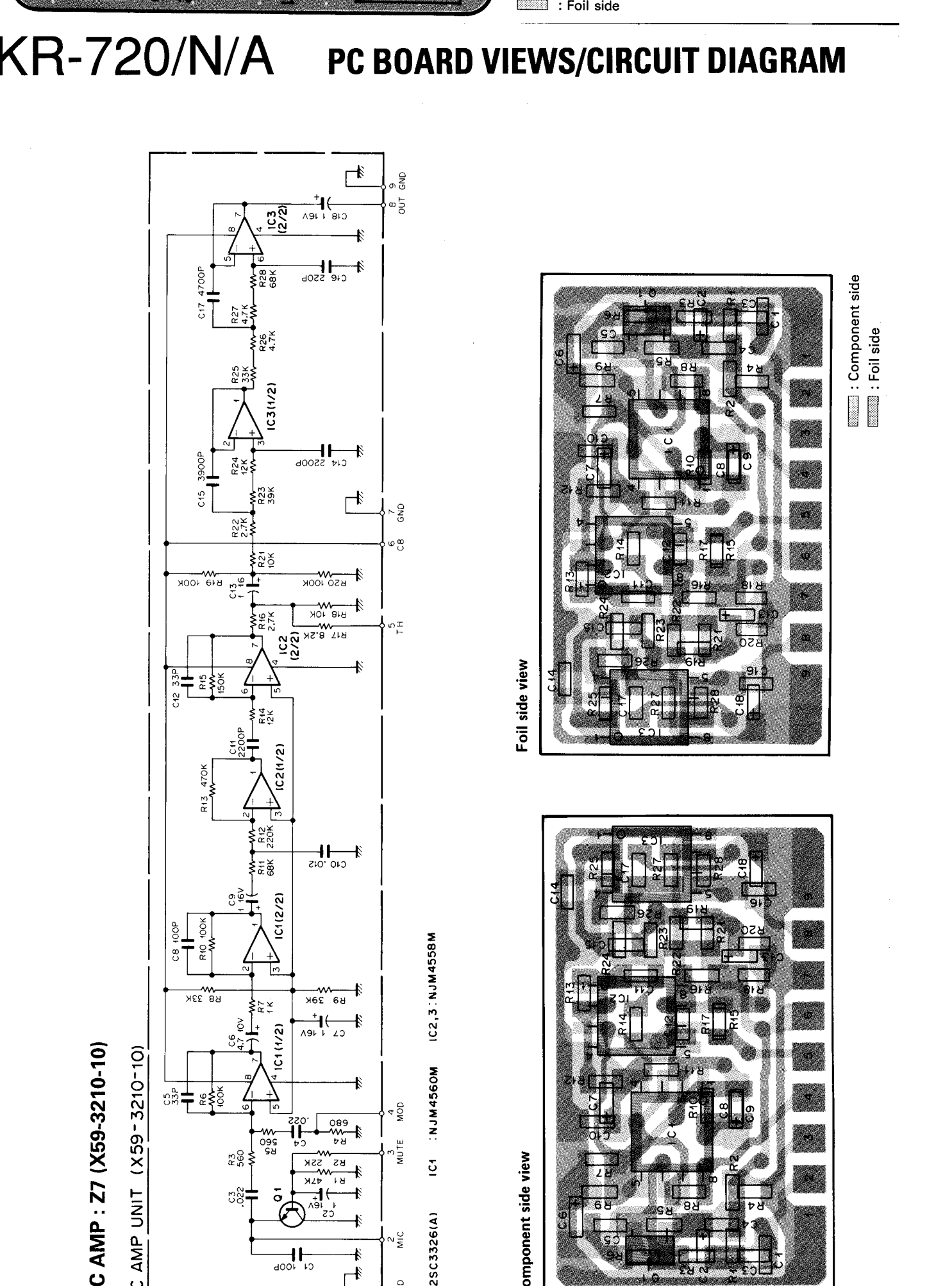
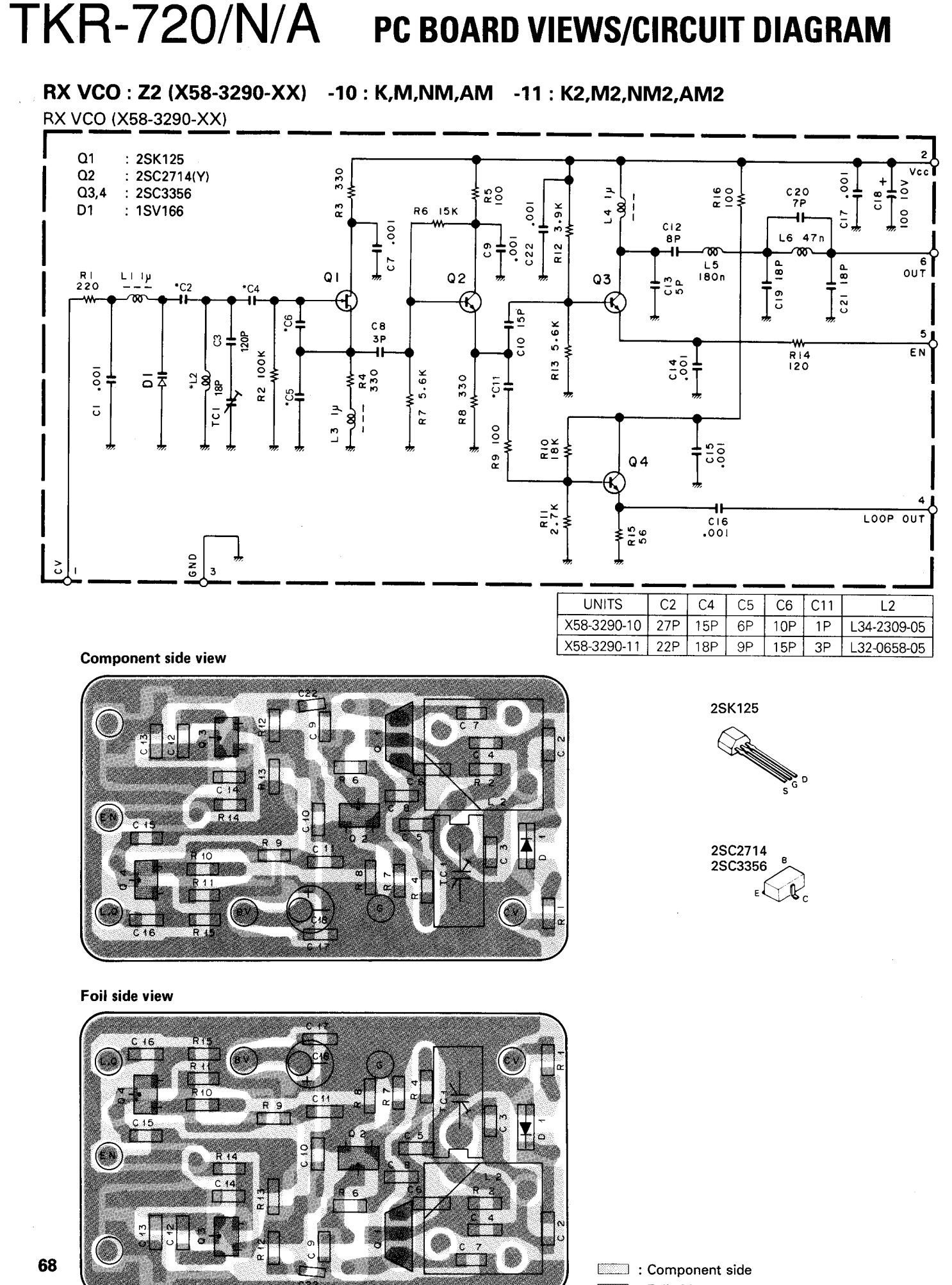
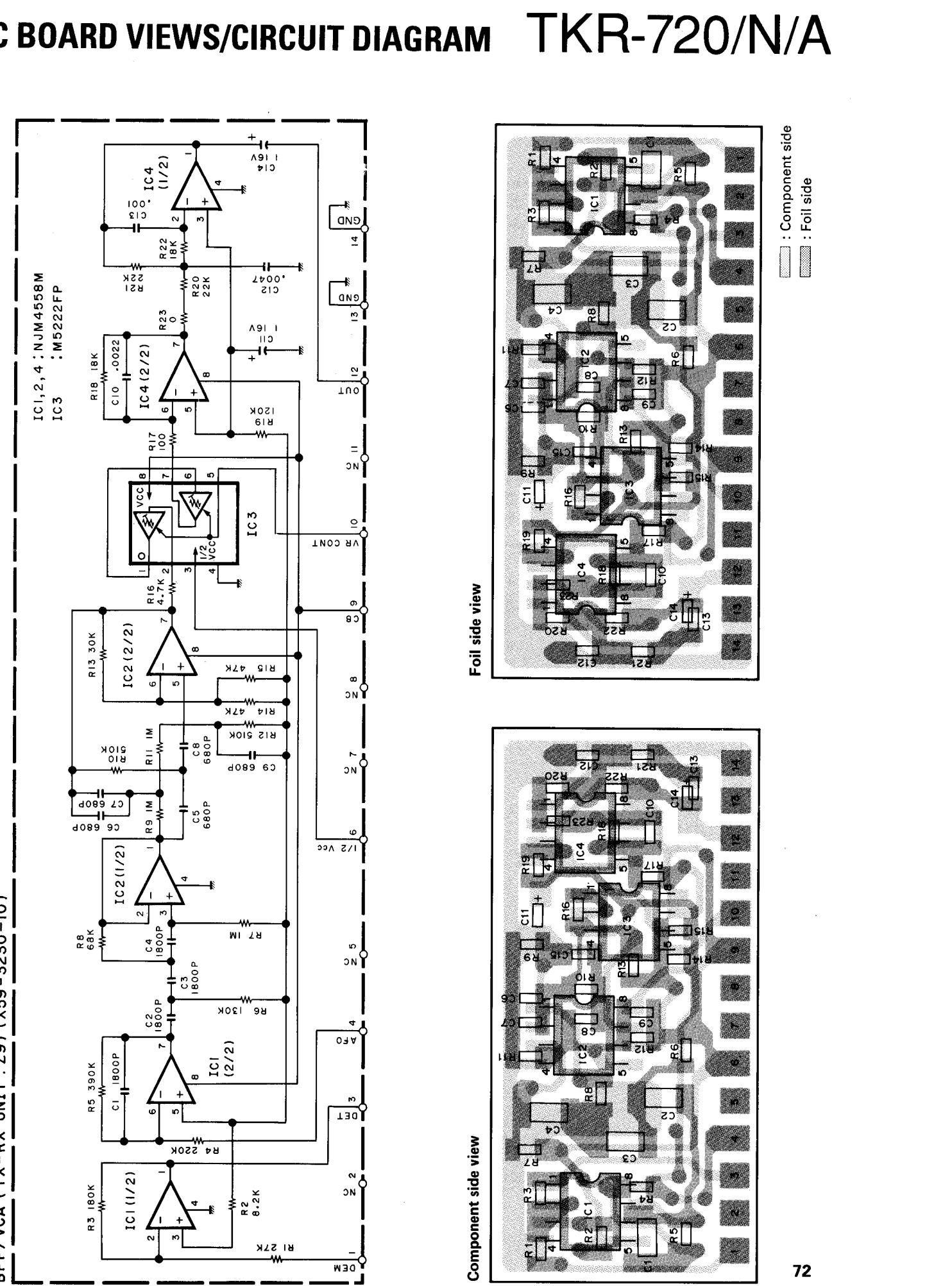
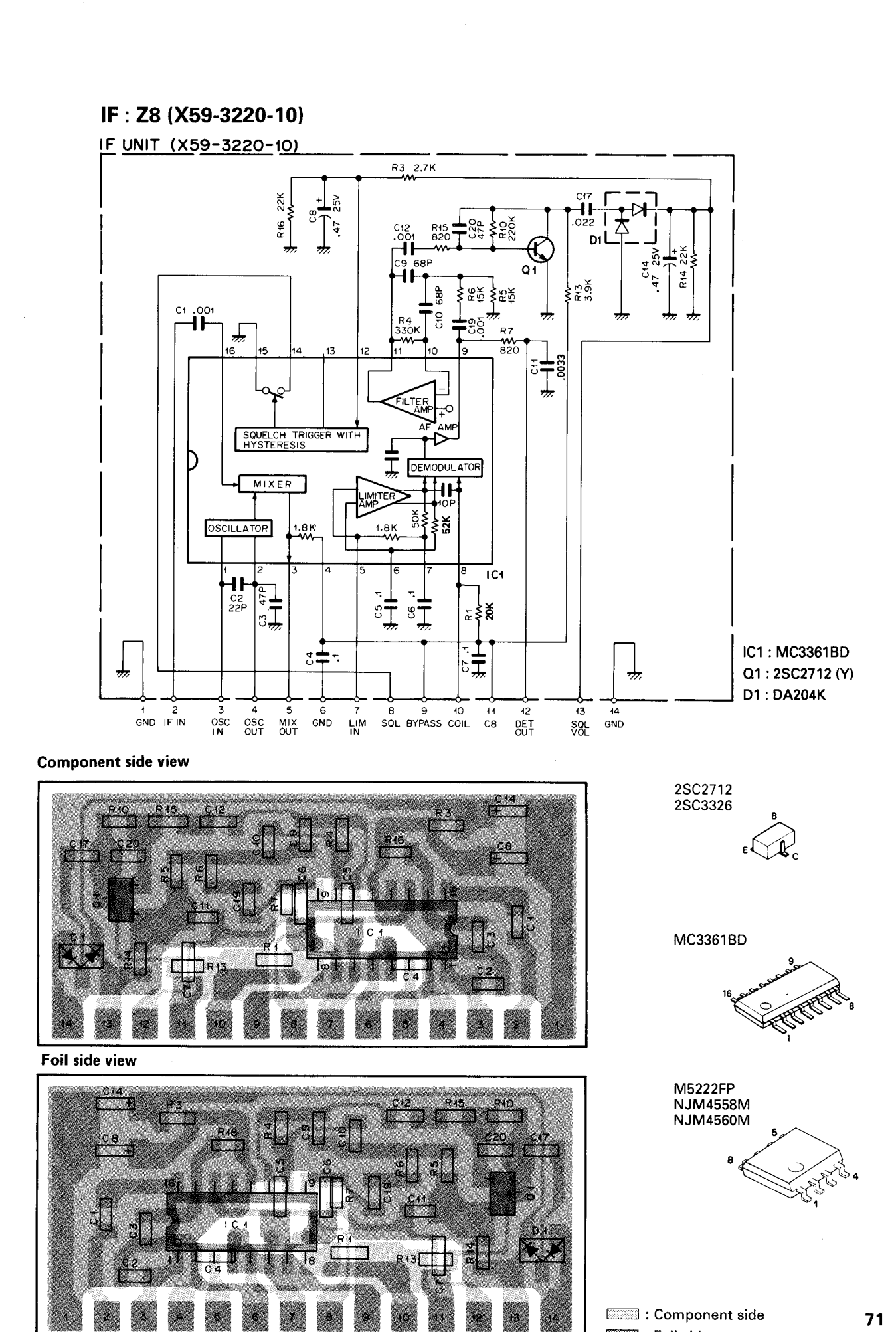
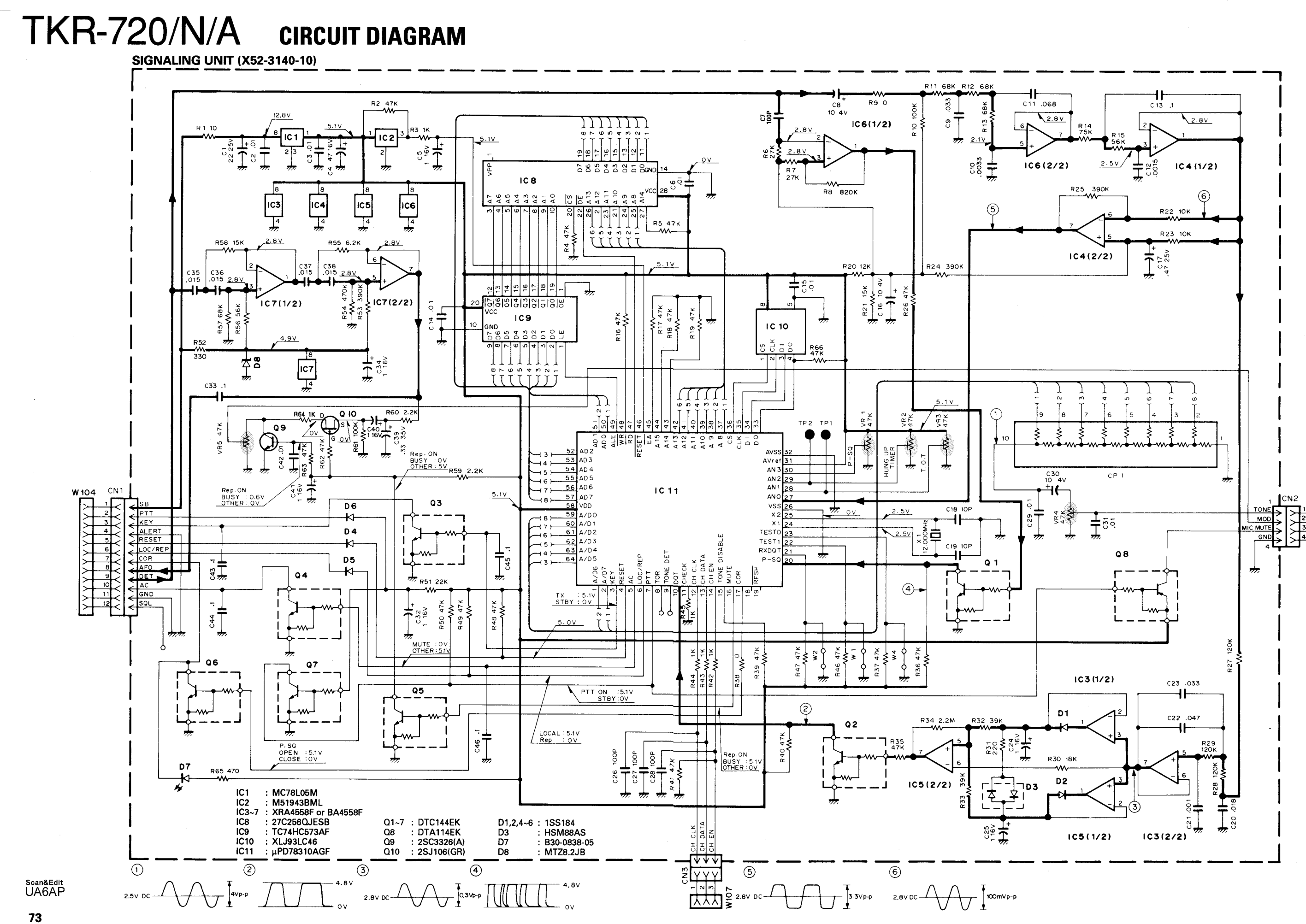
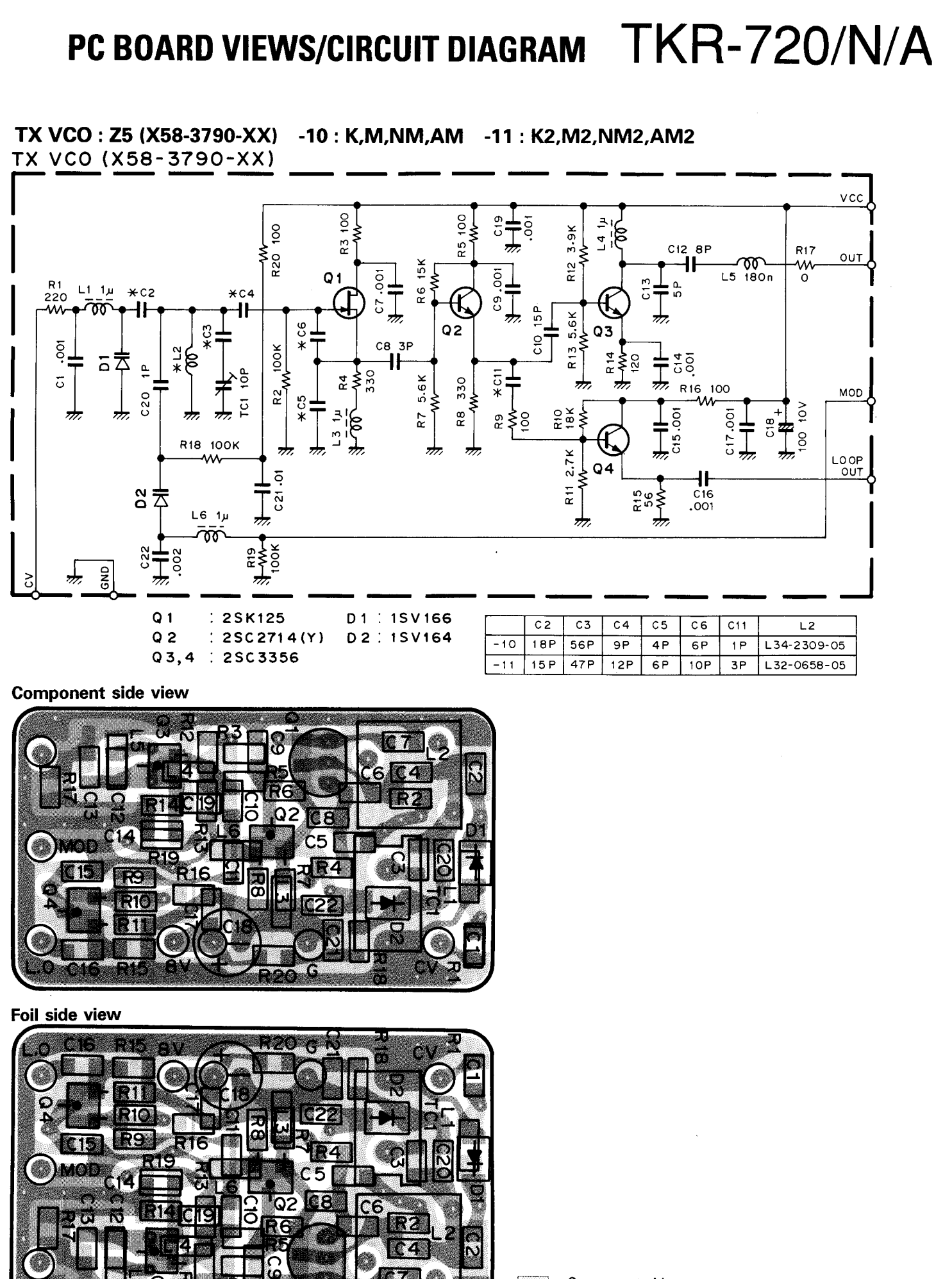
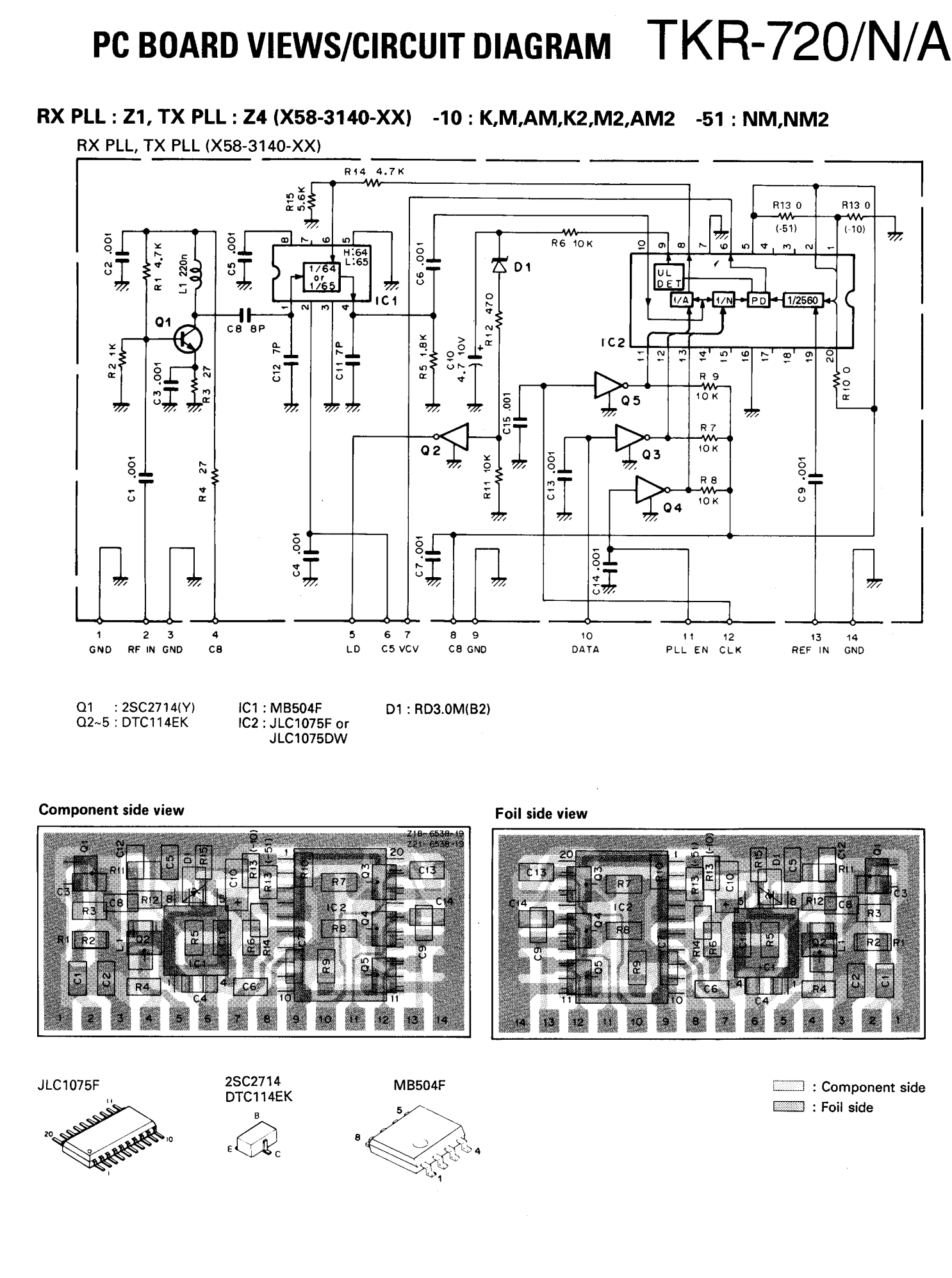
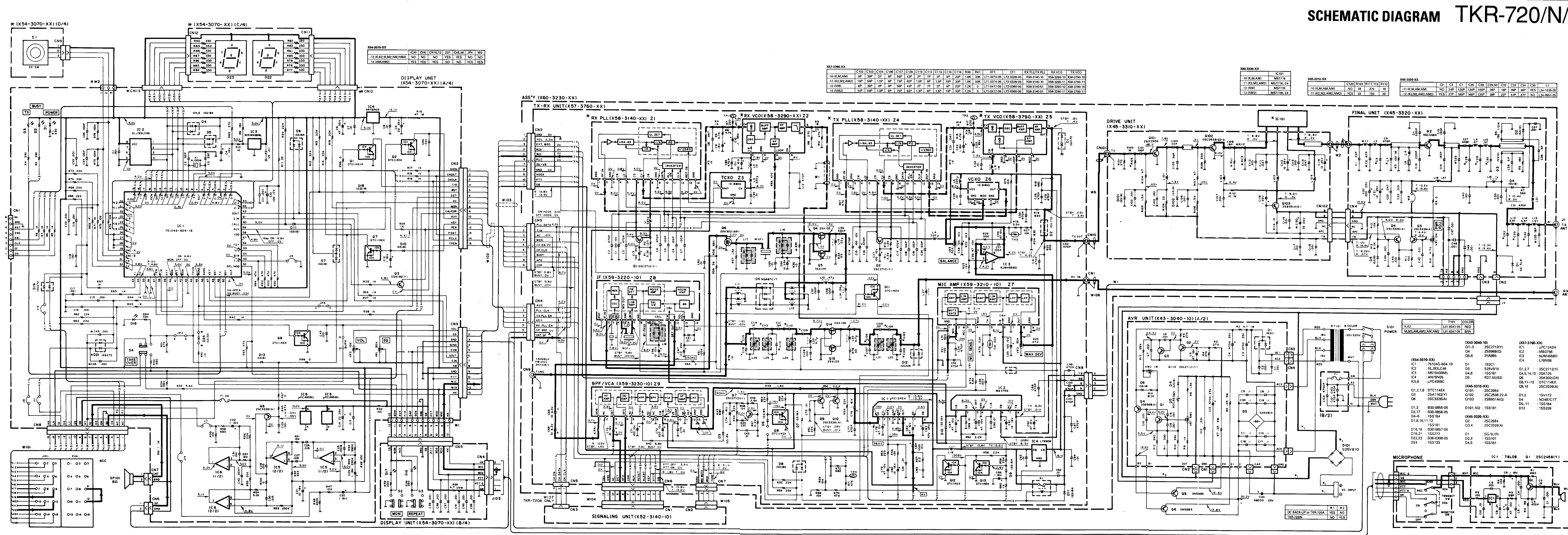

* (X54-3070-XX) (D/4)

* (X54-3070-XX) (C/4)

X54-3070-XX
-12 (K, K2, M, M2, NM, NM2)
-14 (AM, AM2)

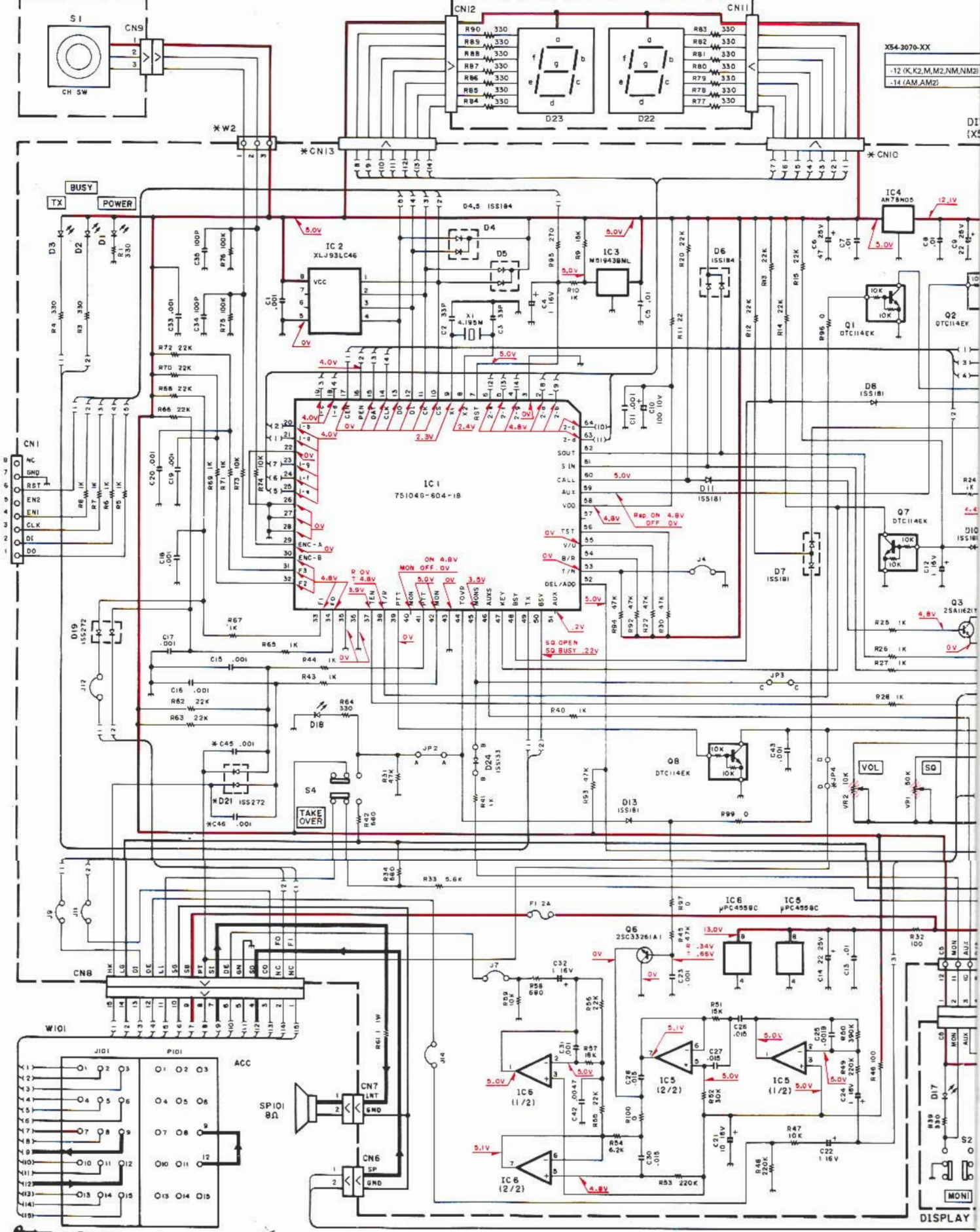

~~Part No. 3228-05~~
~~Part No. 3228-06~~

(P101) = 809-1571-05
MO COX4-

IC4	ID4	CN10,13	D21	C45,46	JP4	W2
NO	NO	NO	YES	YES	NO	NO
YES	YES	YES	NO	NO	YES	YES

DISPLAY UNIT
4-3070-XX (A/4)

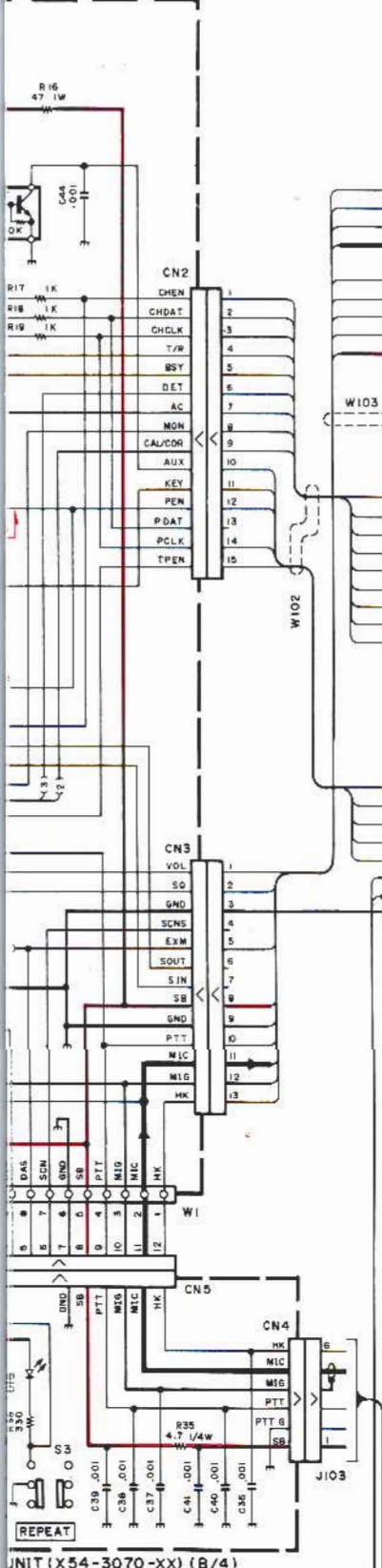

ASS'Y (X60-3230-XX)
TX-RX UNIT (X57-3760-XX)

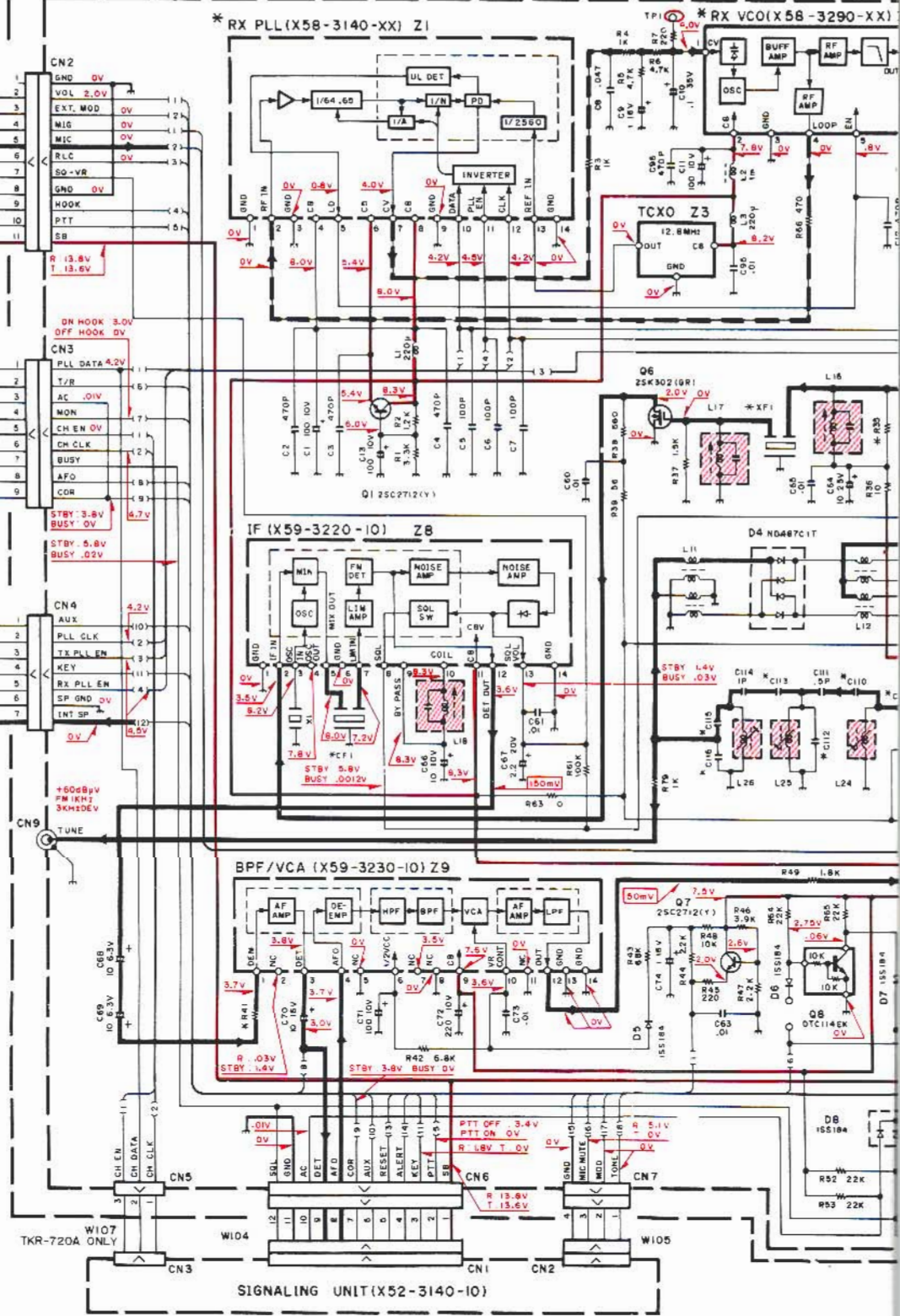

UNIT (X54-3070-XX) (B/4)

X57-3780-XX	C102	C103	C104	C106	C107	C109	C110	C112	C113	C115	C116	R35	R41	XF1	CF1	RX PLL/TX PLL	RX VCO	TX VCO
-10 (K.M.AM)	8P	39P	2P	8P	56P	43P	2P	7P	2P	9P	22P	1.8K	33K	L71-0274-05	L72-0339-05	X58-3140-10	X58-3290-10	X58-3790-10
-11 (K2.M2.AM2)	10P	56P	1.5P	9P	75P	82P	1.5P	9P	1.5P	10P	33P	1.8K	33K	L71-0274-05	L72-0339-05	X58-3140-10	X58-3290-11	X58-3790-11
-12 (NM)	8P	39P	2P	8P	56P	43P	2P	7P	2P	9P	22P	1.2K	0	L71-0417-05	L72-0360-05	X58-3140-51	X58-3290-10	X58-3790-10
-13 (NM2)	10P	56P	1.5P	9P	75P	82P	1.5P	9P	1.5P	10P	33P	1.2K	0	L71-0417-05	L72-0360-05	X58-3140-51	X58-3290-11	X58-3790-11

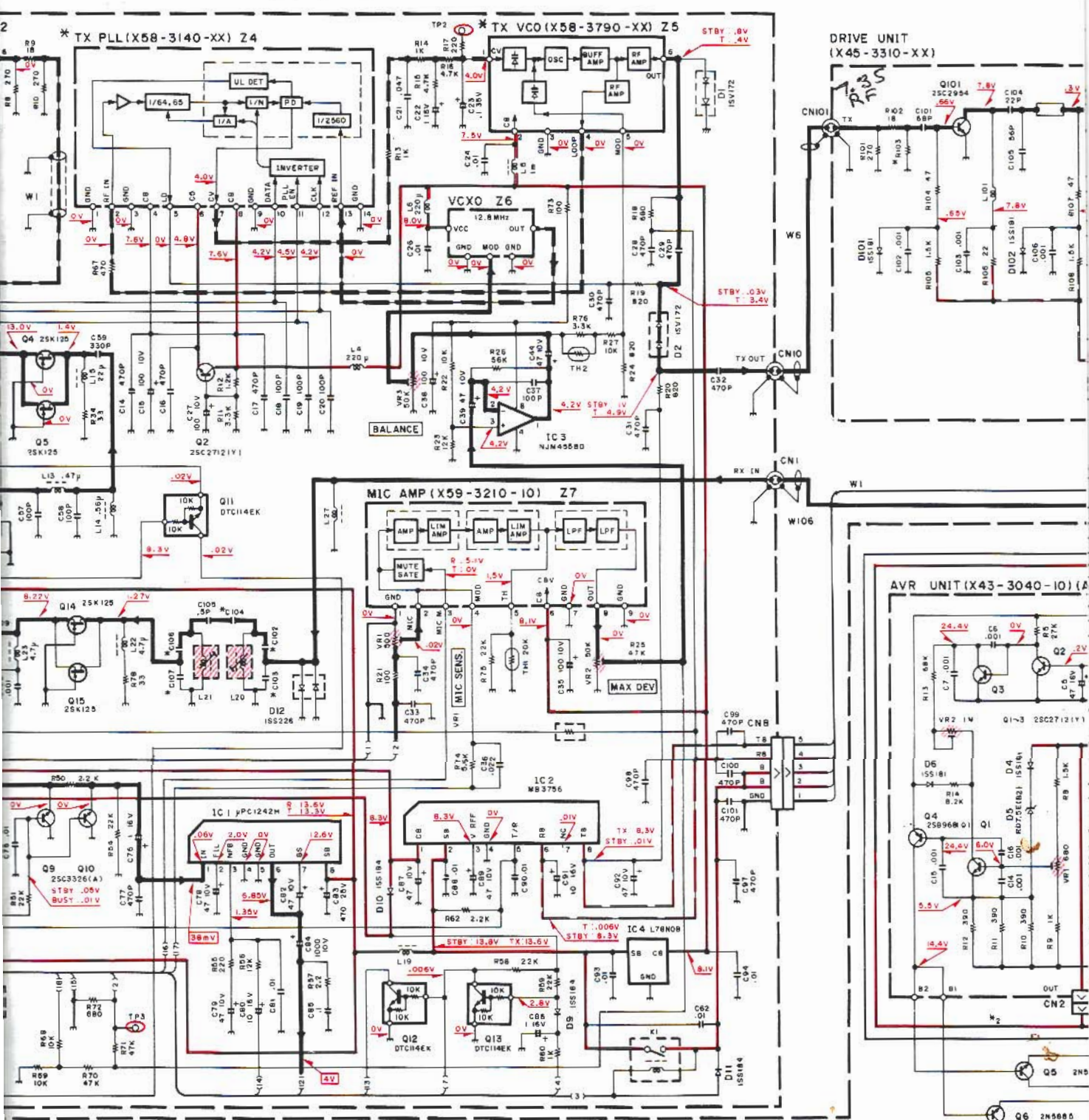

SCHEMATIC DIAGRAM

TKR-720/N/A

X60-3230-XX

IC101	
-10 (K,M,AM)	M57719
-11 (K2,M2,AM2)	M57719L-24
-17 (NM)	M57719
-13 (NM2)	M57719L-24

X45-3310-XX

	C120	R103	R111,113	R112
-10 (K,M,AM,NM)	NO	18	270	18
-11 (K2,M2,AM2,NM2)	YES	33	150	39

X45-3320-XX

	C2	C3	C7	C25	C28	C29,30	C32	C33	C34	C35	L1
-11 (K,M,AM,NM)	NO	24P	120P	120P	100P	36P	18P	39P	39P	YES	L34-1039-05
-12 (K2,M2,AM2,NM2)	YES	27P	180P	160P	120P	39P	22P	51P	47P	NO	L34-0951-05

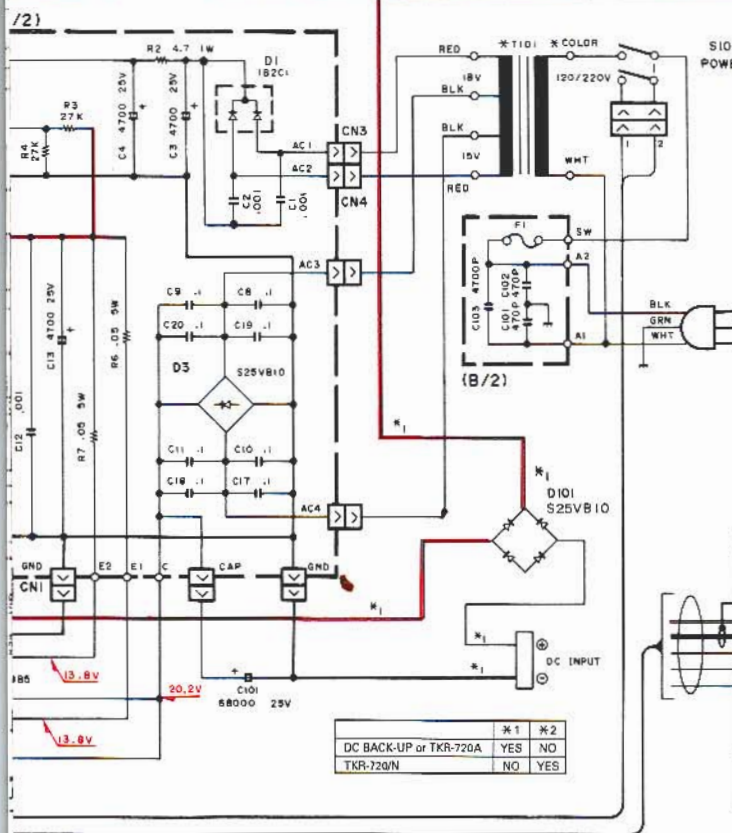
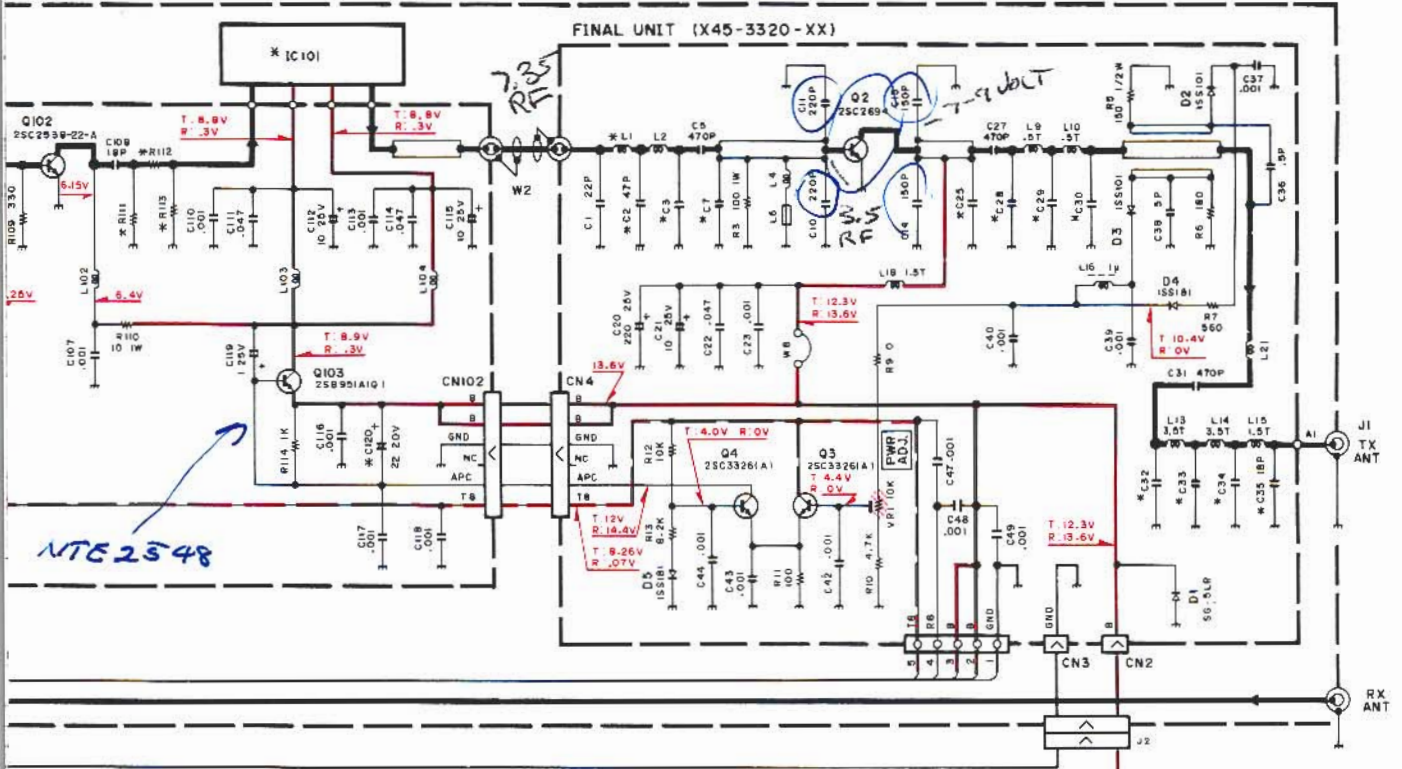

	T101	COLOR
K,K2	L01-8341-05	RED
M,M2,AM,AM2,NM,NM2	L01-8347-05	BRN

- | | | |
|------------------------|----------------------|----------------------|
| (X54-3070-XX) | (X43-3040-10) | (X57-3760-XX) |
| IC1 : 75104G-604-1B | Q1-3 : 2SC2712(Y) | IC1 : μ PC1242H |
| IC2 : XLJ93LC46 | Q4 : 2S8968(Q) | IC2 : MB3756 |
| IC3 : M51943BML | Q5,6 : 2N5885 | IC3 : NJM4558D |
| IC4 : AN78N05 | | IC4 : L78N08 |
| IC5,6 : μ PC4568C | D1 : 1B2C1 | Q1,2,7 : 2SC2712(Y) |
| Q1,2,7,8 : DTC114EK | D3 : S25VB10 | Q4,5,14,15 : 29K125 |
| Q3 : 2SA1162(Y) | D4,6 : 1SS181 | O6 : 29K302(GR) |
| O6 : 2SC3326(A) | D5 : RD75E(B2) | Q8,11-13 : DTC114EK |
| D1,3 : B30-0855-05 | | Q9,10 : 2SC3325(A) |
| D2,17 : B30-0856-05 | (X45-3310-XX) | D1,2 : 15V172 |
| D4-6 : 1SS184 | Q101 : 2SC2954 | D4 : ND487C1T |
| D7,8,10,11,13 : 1SS181 | Q102 : 2SC2538-22-A | D5-11 : 1SS184 |
| D16,18 : B30-0857 05 | Q103 : 2S8951A(Q) | D12 : 1SS226 |
| O19,21 : 1SS272 | (X45-3320-XX) | |
| O22,23 : B38 0308-05 | Q2 : 2SC2694 | |
| O24 : 1SS133 | Q3,4 : 2SC3326(A) | |
| | D1 : SG-5LIRI | |
| | D2,3 : 1SS101 | |
| | D4,5 : 1SS181 | |

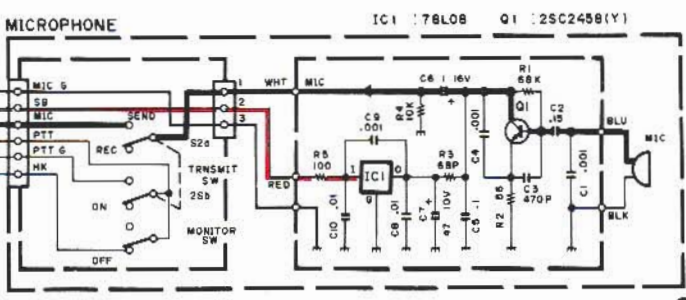

TERMINAL FUNCTION

Connector No.	Pin No.	Pin Name	Function
AVR UNIT (X43-3040-10)			
(A/2)		AC1	AC input for reference voltage.
		AC2	AC input for reference voltage.
		AC3	AC input for power supply.
		AC4	AC input for power supply.
		GND	GND.
		CAP	For capacitor (+).
		C	Q5, Q6 collector.
		E1	For emitter Q6.
		E2	For emitter Q5.
		GND	GND for output.
		OUT	DC 13.6V output.
		B1	For base Q6.
		B2	For base Q5.
(B/2)		A1	AC power input.
		A2	AC power input.
		SW	Fused AC output.
DRIVE UNIT (X45-3310-XX)			
CN101	-	TX	Transmission signal input, coaxial connector.
CN102	1	B	DC 13.6V input
	2	B	DC 13.6V input.
	3	GND	GND.
	4	NC	No connect.
	5	APC	APC control input.
	6	T8	TX 8V output.
W2	-	DO	Drive output.
FINAL UNIT (X45-3320-XX)			
CN2	-	B	DC power supply input.
CN3	-	GND	GND.
CN4	1	B	DC 13.6V output.
	2	B	DC 13.6V output.
	3	GND	GND.
	4	NC	No connect.
	5	APC	APC control output.
	6	T8	TX 8V input.
W1	1	GND	GND.
	2	B	DC 13.6V output.
	3	B	DC 13.6V output.
	4	R8	RX 8V input.
	5	T8	TX 8V input.
W2	-	DO	RF drive input.
J1	-	ANT	Transmission signal output, antenna connector.
SIGNALING UNIT (X52-3140-10)			
CN1	1	SB	Power supply input via the power switch.
	2	PTT	PTT signal input.
	3	KEY	KEY signal input.
	4	ALERT	ALERT signal output.
	5	RESET	RESET signal input.
	6	LOC/REP	REPEAT signal input.
	7	COR	Busy signal output by the internal squelch.
	8	AFO	Detection signal output.
	9	DET	Detection signal output.
	10	AC	Audio mute control signal output.
	11	GND	GND.
	12	SQL	Noise squelch signal input.

Connector No.	Pin No.	Pin Name	Function
CN2	1	TONE	TONE signal (300Hz or less) output.
	2	MOD	MOD signal (300Hz to 3kHz) output.
	3	MIC MUTE	MIC MUTE signal output.
	4	GND	GND.
CN3	1	CH CLK	CH CLOCK signal input.
	2	CH DATA	CH DATA signal input.
	3	CH EN	CH ENABLE signal input.
DISPLAY UNIT (X54-3070-XX)			
CN1	1	DO	EEPROM data output.
For EEPROM writer	2	DI	EEPROM data input.
	3	CLK	Clock signal input.
	4	EN1	EEPROM enable signal input 1.
	5	EN2	EEPROM enable signal input 2.
	6	RST	Microprocessor reset input.
	7	GND	GND.
	8	NC	No connection
CN2	1	CH EN	Channel enable.
	2	CH DAT	Channel data.
	3	CH CLK	Channel clock.
	4	T/R	Transmit/receive.
	5	BSY	Busy.
	6	DET	Detected signal input.
	7	AC	Audio mute control signal.
	8	MON	Monitor.
	9	CAL/COR	CALL/COR.
	10	AUX	REP/LOCAL.
	11	KEY	KEY line.
	12	P EN	RX PLL enable.
	13	P DAT	PLL data.
	14	P CLK	PLL clock.
	15	TP EN	TX PLL enable.
CN3	1	VOL	Volume control input.
	2	SQ	Squelch control input.
	3	GND	GND.
	4	SCNS	Scan signal input.
	5	EXM	
	6	SOUT	Serial output.
	7	SIN	Serial input.
	8	SB	Switched B input.
	9	GND	GND.
	10	PTT	PTT signal output.
	11	MIC	MIC signal output.
	12	MIG	MIC GND.
	13	HK	HOOK signal output.
CN4 (B/4) For MIC	1	SB	Switched B output.
	2	GND	GND.
	3	PTT	PTT.
	4	MIG	MIC GND.
	5	MIC	MIC.
	6	HOOK	HOOK.
CN5 (B/4)	1	C5	Common 5V.
	2	MON	MONITOR signal output.
	3	AUX	AUX signal output.
	4	D/A	DEL/ADD LED signal input.
	5	DAS	DEL/ADD signal output.
	6	SCN	Scan signal output.
	7	GND	GND.
	8	SB	Switched B input.
	9	PTT	PTT signal output.
	10	MIG	MIC GND.
	11	MIC	MIC signal output.
	12	HK	HOOK signal output.

TERMINAL FUNCTION

Connector No.	Pin No.	Pin Name	Function
CN6	1	SP	Speaker input.
	2	GND	GND.
CN7	1	INT	Internal speaker output.
	2	GND	GND.
CN8 For ACC connector	1	NC	No connection.
	2	NC	No connection.
	3	CO	CALL/COR or BUSY signal output.
	4	SO	Speaker signal output.
	5	GN	GND.
	6	DE	Detected signal output.
	7	SI	Speaker signal input.
	8	PT	PTT signal input.
	9	SB	Switched B output.
	10	SG	Speaker GND.
	11	LI	Line input.
	12	DE	Detected signal output.
	13	DI	Direct modulation input.
	14	LG	Line input GND.
	15	HK	HOOK signal input.
CN9 (D/4)	1	+B	Power supply input.
	2	ENC1	Encoder signal output.
	3	ENC2	Encoder signal output.
W1	1	HK	HOOK signal input.
	2	MIC	MIC signal input.
	3	MIG	MIG GND.
	4	PTT	PTT signal input.
	5	SB	Switched B output.
	6	GND	GND.
	7	SCN	Scan signal input.
	8	DAS	DEL/ADD signal input.
	9	D/A	DEL/ADD LED signal output.
	10	AUX	AUX signal input.
	11	MON	MONITOR signal input.
	12	C5	Common 5V output.
W2	1	ENC2	Encoder signal input.
	2	ENC1	Encoder signal input.
	3	+B	Power supply output.
TX-RX UNIT (X57-3760-XX)			
CN1		RX IN	Receiver signal input, coaxial connector.
CN2	1	GND	GND.
	2	VOL	Electronic volume control signal output.
	3	EXT MOD	External modulation input.
	4	MIG	MIC GND.
	5	MIC	MIC signal input.
	6	RLC	Power supply relay control signal output to the power switch.
	7	SQ VR	Detection signal output to SQL volume.
	8	GND	GND.
	9	HOOK	HOOK signal (MIC hook) input.
	10	PTT	PTT signal input.
	11	SB	Power supply output via the power switch.

Connector No.	Pin No.	Pin Name	Function
CN3	1	PLL DATA	PLL DATA signal input.
	2	T/R	T/R signal input.
	3	AC	Audio mute control signal input by the signaling unit.
	4	MON	MONITOR signal input.
	5	CH EN	CH ENABLE for signaling.
	6	CH CLK	CH CLOCK for signaling.
	7	BUSY	BUSY signal output.
	8	AFO	Detection signal input via the signaling unit.
	9	COR	BUSY signal output by the signaling unit.
CN4	1	AUX	REPEAT signal input.
	2	PLL CLK	PLL CLOCK signal input.
	3	TX PLL EN	TX PLL ENABLE signal input.
	4	KEY	KEY signal input.
	5	RX PLL EN	RX PLL ENABLE signal input.
	6	SP GND	Internal speaker GND.
	7	INT SP	Internal speaker output.
CN5	1	CH CLK	CH CLOCK signal output for signaling.
	2	CH DATA	CH DATA signal output for signaling.
	3	CH EN	CH ENABLE signal output for signaling.
CN6	1	SB	Power supply output via the power switch.
	2	PTT	PTT signal output for signaling.
	3	KEY	KEY signal output for signaling.
	4	ALERT	ALERT signal input for signaling.
	5	RESET	RESET signal output for signaling.
	6	AUX	REPEAT signal output for signaling.
	7	COR	BUSY signal input by the signaling unit.
	8	AFO	Detection signal input to the signaling unit.
	9	DET	Detection signal output by the signaling unit.
	10	AC	Audio mute control signal input by the signaling unit.
	11	GND	GND.
	12	SQL	Noise squelch signal output.
CN7	1	TONE	TONE signal (300Hz or less) input.
	2	MOD	MOD signal (300Hz to 3kHz) input.
	3	MIC MUTE	MIC MUTE signal input.
	4	GND	GND.
CN8	1	GND	GND.
	2	B	Power supply input (from Final to TX-RX).
	3	B	Power supply input (from Final to TX-RX).
	4	R8	RX 8V output.
	5	T8	TX 8V output.
CN9	-	TUNE	Filtered RX signal output, coaxial connector (for assemble line).
CN10		TX OUT	Transmission drive output, coaxial connector.

KMC-9 (BASE MICROPHONE)

KMC-9 External View



KMC-9 Disassembly for Repair

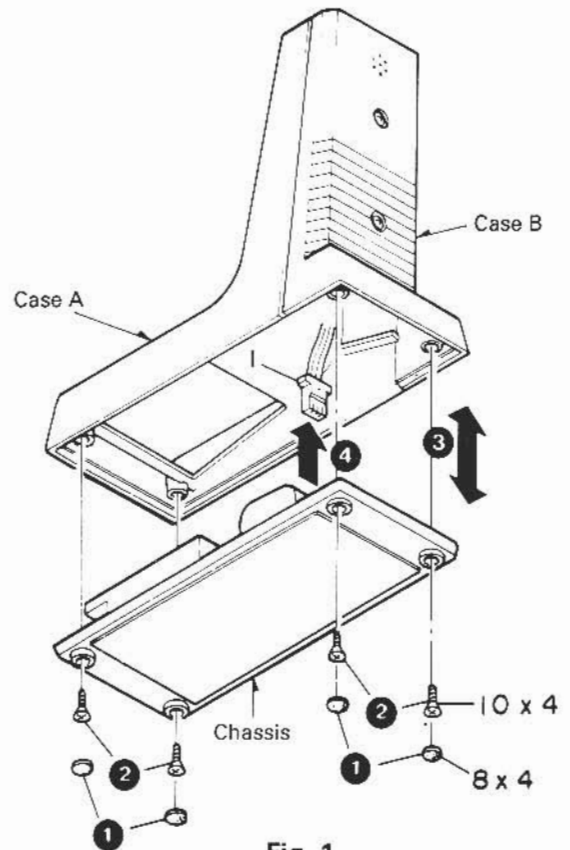

Fig. 1

- **Chassis removal**

1. Remove the four rubber feet (1).
2. Remove the four screws (2).
3. Remove the chassis (3).
4. Disconnect the 3-pin connector from the microphone amplification unit (4).

- **Removal of microphone element and microphone amplification unit**

5. Remove the two screws holding cases A and B (5).
6. Remove case B (6).
7. Remove the microphone element and microphone amplification unit (7).

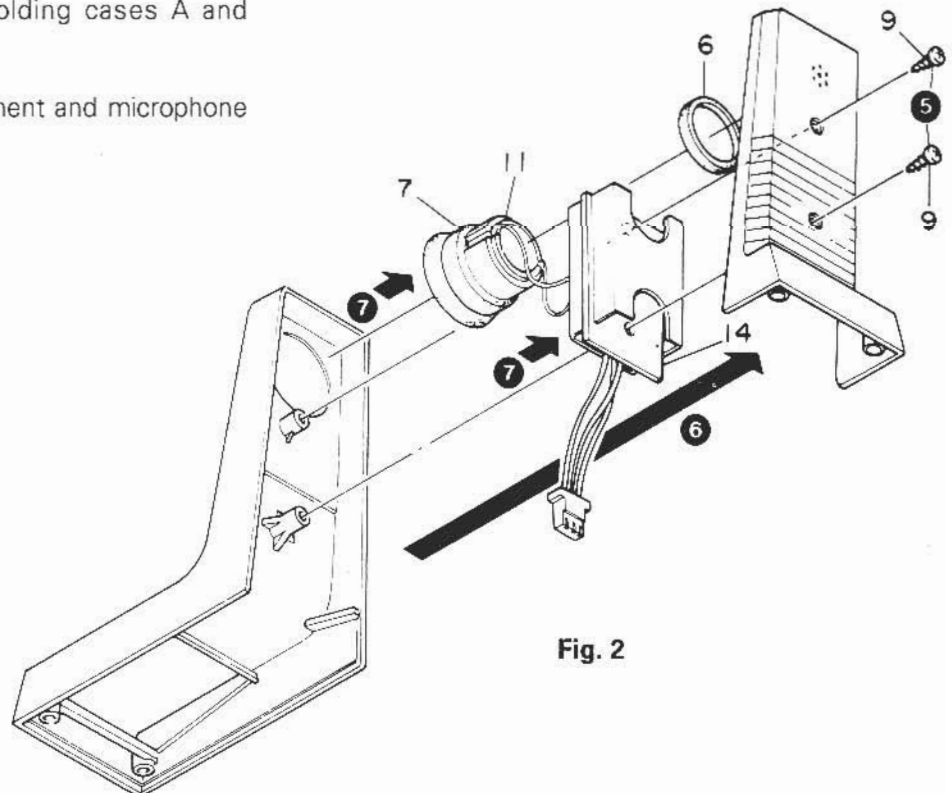

Fig. 2

TKR-720/N/A

KMC-9 (BASE MICROPHONE)

• Switch unit removal

8. Disconnect the 6-pin connector (8).
9. Remove the springs (L and R) (9).
10. Pull out the shaft (10).
11. Remove spring A and slider (11).
12. Remove the switch unit while pressing the two claws holding the switch unit in the direction of the arrow (12).

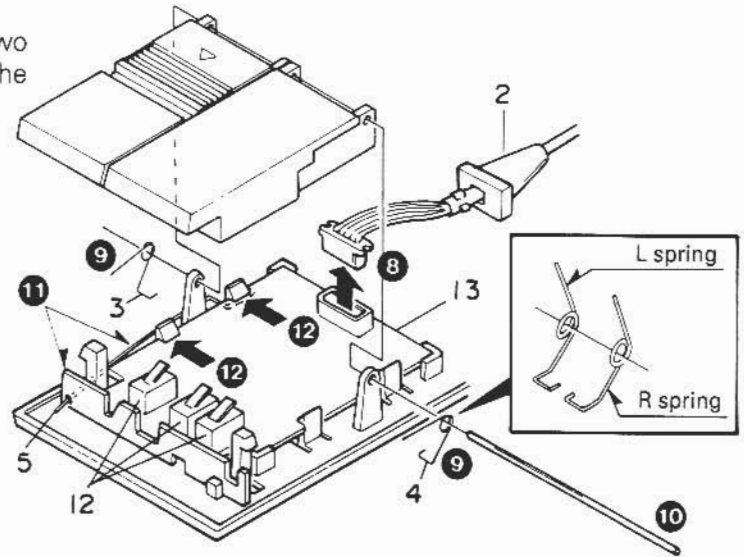

Fig. 3

• Removing microphone plug

To remove the microphone plug (module) from the Main unit or from the microphone, grasp the rubber cap from up and down with your fingers (to unlock it) and pull it out.

KMC-9 Parts List

* : New parts

Ref. No.	New parts	Parts No.	Description
1		E23-0612-08	Crimp terminal
2		E30-2080-08	Curl cord
3		G09-0423-08	L spring
4		G09-0424-08	R spring
5		G09-0425-08	Spring A
6		G13-0877-08	Cushion
7		G13-0878-08	Cushion D
8		J02-0448-08	Rubber foot
9		N44-3018-45	Tapping screw
10		N47-3010-46	Tapping screw
11		T91-0368-08	MIC unit
12		S50-1430-08	Micro switch
13		W02-0803-08	SW unit
14		W02-0395-08	MIC AMP unit

KMC-9 (BASE MICROPHONE)

KMC-9 Circuit Diagram

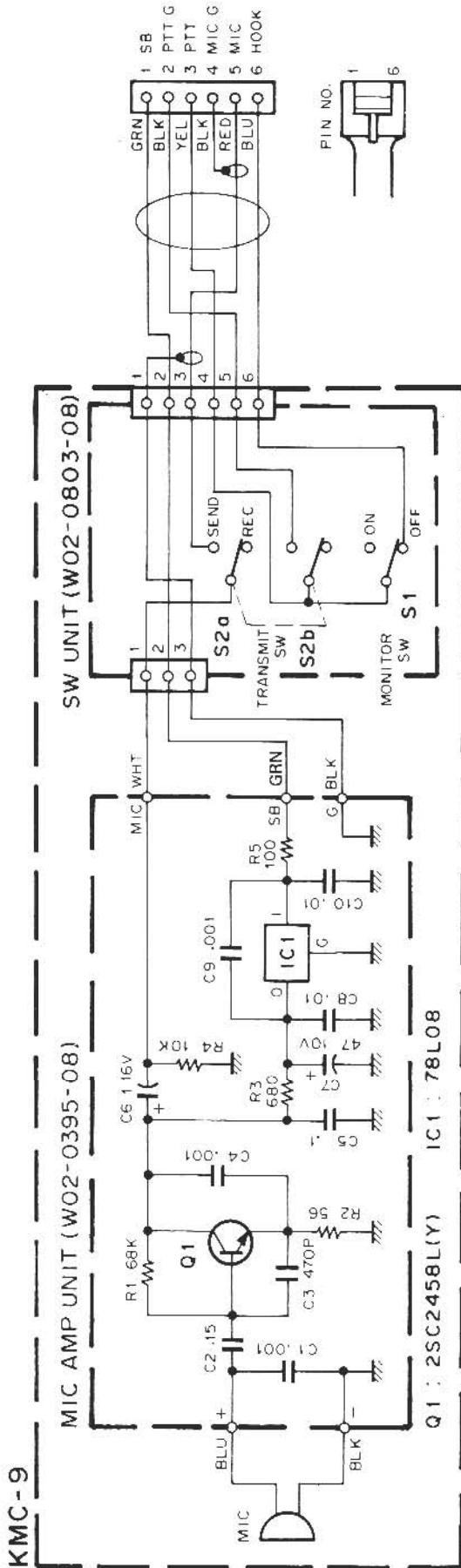

KMC-9 Specifications

- Type Uni-directional dynamic microphone (Preamplifier built-in)
- Output impedance $600\Omega \pm 30\%$ (at 1kHz)
- Sensitivity $-50\text{dB} \pm 3\text{dB}$ (at 1kHz, $0\text{dB} = 1\text{V}/\mu\text{bar}$)
- Frequency characteristic 300 to 3000Hz ($\pm 6\text{dB}$)
- Power requirements 13.8V DC (Supplied from the radio)
- Dimensions (W x H x D) 70 x 162 x 150 mm (2-3/4 x 6-3/8 x 5-29/32 inch)
- Weight 550g (1.2 lbs)

SPECIFICATIONS

GENERAL

Frequency Range	150 to 174MHz : K,M,NM,AM 136 to 150MHz : K2,M2,NM2,AM2
Number of channels	1 : TKR-720/N 16 : TKR-720A
Channel Spacing	30kHz : K,K2 30kHz (25kHz) : M,M2,AM,AM2 12.5kHz : NM,NM2
PLL Channel Step	5kHz : TKR-720/A 6.25kHz : TKR-720N
Input Voltage	120/220V AC, 50/60Hz (Modifiable to DC backup)
Power Consumption	230W max.
Duty Cycle	50% at 50W output (100% at 15W output)
Temperature Range	-30°C to +60°C (-22°F to +140°F)
Dimensions	H : 4.72" (120mm) W : 12.99" (330mm) D : 15.08" (383mm)
Weight	28.66lbs (13kg)

RECEIVER (Measurements made per EIA standard EIA-204-C)

RF Input Impedance	50Ω
Sensitivity	
EIA 12dB SINAD	0.35μV
20dB Quieting	0.45μV
Squelch Sensitivity	0.2μV threshold
Modulation Acceptance	±7kHz : TKR-720/A ±3.5kHz : TKR-720N
Selectivity	-85dB : TKR-720/A -75dB : TKR-720N
Intermodulation	-80dB : TKR-720/A -70dB : TKR-720N
Spurious and Image Rejection ...	-90dB
Audio Power Output	4W at 4Ω less than 5% distortion
Frequency Stability	±0.0005% from -30°C to +60°C

TRANSMITTER (Measurements made per EIA standard EIA-152-B)

RF Power Output : 50W adjustable to 15W (Duplexer input)	
RF Output Impedance	50Ω
Spurious and Harmonics ...	-80dB
Modulation	
Direct FM Modulation ...	F3E, ±5kHz for 100% at 1000Hz : TKR-720/A F3E, ±2.5kHz for 100% at 1000Hz : TKR-720N
FM Noise	-50dB : TKR-720/A -45dB : TKR-720N
Microphone Impedance	Low impedance
Audio Distortion	Less than 3% at 1000Hz
Frequency Stability	±0.00025% from -30°C to +60°C

SIGNALING

Maximum Number of Tone Combination	8
QT Decoder/Encoder	
Decoder/Encoder Tone Frequency	67.0 to 210.7Hz (in 0.1Hz steps)
Decoder Response Time	200msec. or less
Squelch tail Elimination Time	100msec.
Encoder Frequency Error	±0.05% or less
Sensitivity	SINAD 8dB or less
DQT Decoder/Encoder	
DQT Code	23 bits total ; a 3-digit octal number (0 to 7 and 12 bits) with error correction (11 bits)
Decoder Response time	250msec. or less
Turn-off Code Transmission Time	156msec.
Squelch Sensitivity	SINAD 8dB or less
Time-out-timer	Adjustable OFF 30sec. to 5min.
Hang up Timer	Adjustable 0 to 5sec.
Preset Squelch Sensitivity	0.2μV threshold, 12dB SINAD +10dB or less tight

KENWOOD CORPORATION

14-6, Dogenzaka 1-chome, Shibuya-ku, Tokyo 150, Japan

KENWOOD SERVICE CORPORATION

P.O. BOX 22745, 2201 East Dominguez Street, Long Beach, CA 90801-5745, U.S.A.

KENWOOD ELECTRONICS LATIN AMERICA S.A.

P.O. BOX 55-2731 Piso 6 Plaza Chase Cl. 47 y Aquilino de la Guardia Panama, Republic of Panama

KENWOOD ELECTRONICS CANADA INC.

6070 Kestrel Road, Mississauga, Ontario, Canada L5T 1S8

KENWOOD ELECTRONICS DEUTSCHLAND GMBH

Rembrücker Str. 15, 6056 Heusenstamm, Germany

KENWOOD ELECTRONICS BENELUX N.V.

Mechelsesteenweg 418 B-1930 Zaventem, Belgium

TRIO-KENWOOD FRANCE S.A.

13, Boulevard Ney, 75018 Paris, France

TRIO-KENWOOD U.K. LIMITED

KENWOOD House, Dwight Road, Watford, Herts., WD1 8EB United Kingdom

KENWOOD ELECTRONICS NEDERLAND B.V.

Amsterdamseweg 35, 1422 AC Uithoorn, The Netherlands

KENWOOD ELECTRONICS ITALIA S.p.A.

Via G. Sirtori, 7/9 20129 Milano, Italy

KENWOOD IBERICA S.A.

Bolivia, 239-08020 Barcelona, Spain

KENWOOD ELECTRONICS AUSTRALIA PTY. LTD.

(A.C.N. 001 499 074)

P.O. Box 504, 8 Figtree Drive, Australia Centre, Homebush, N.S.W. 2140, Australia

KENWOOD & LEE ELECTRONICS, LTD.

Unit 3712-3724, Level 37, Tower one Metroplaza, 223 Hing Fong Road, Kwai Fong, N.T., Hong Kong

SERVICE BULLETIN Land Mobile Division

SUBJECT TKR-720/820 CHANNEL SELECTION VIA THE ACCESSORY CONNECTOR	DATE 03/16/92
--	----------------------

The TKR-720 and TKR-820 are normally programmed with one channel and up to 8 QT or DQT tones. The following information will allow selection of up to four channels from the accessory connector. Optionally, this capability also permits selection of the first 4 tones for use as default tones for dispatch purposes.

On TKR-820's prior to S/N 104XXXX, diode D19 and jumper J12 need to be installed on the Display board. The revised TKR-820 Service Manual, Part Number B51-8050-00, shows the proper location of these components. TKR-720's already include the parts necessary for channel selection via the accessory connector.

PROCEDURE:

1. Program channels 1 to 4 in the usual manner with the KPT-20.
2. Prepare a rectangular plug to be inserted into the accessory jack. The plug will require male crimp terminals, Part Number E23-0613-05, to be inserted into positions 1, 11, 14, and 15. Pin 1 is the hook line which must be grounded in order to change channels. Pin 11 is ground. Pins 14 and 15 are BCD channel selection lines. These lines are normally held "HI" with pull-up resistors on the Display board.
3. If selectable default tones are desired, program the Signaling board EEPROM accordingly with the KPT-20. The default tone is the tone encoded during transmit (PTT) when COR is NOT present. JAQ4 software (see Service Bulletin T-89-88-LM) must be used in the Signaling unit to facilitate default tone operation.
4. Connect a 3 pin wire harness (Part Number E31-3341-05) from the TX-RX board connector CN5 to the Signaling board connector CN3.

When arranged for selectable channels and default tones, the TKR-720/820 can be programmed with a common channel and different selectable default tones or vice versa. Any tone that is programmed (8 tones maximum), however, is available for repeat use regardless of the channel selected.

In order to change channels, pins 14 and 15 must be pulled low as follows:

	CH1	CH2	CH3	CH4
PIN 14	H	L	H	L
PIN 15	H	H	L	L

MALE PIN CRIMP TERMINALS (E23-0613-05)

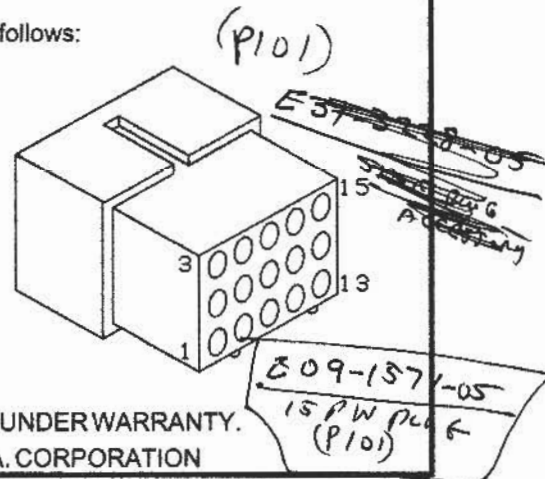

THIS IS AN OPTIONAL CHANGE THAT IS NOT COVERED UNDER WARRANTY.
 COPYRIGHT (C) 03/16/92 EWP FOR KENWOOD U.S.A. CORPORATION

no copy

MOLEX PINS .062

MC M #

28-9420 CRIMP - RM. .062

WALDOM # 02-06-1103
(MOLEX)

196 CA

28-9415 - CRIMP MOLEX .062

WALDOM # 02-06-2103
(MOLEX)

196 CA.

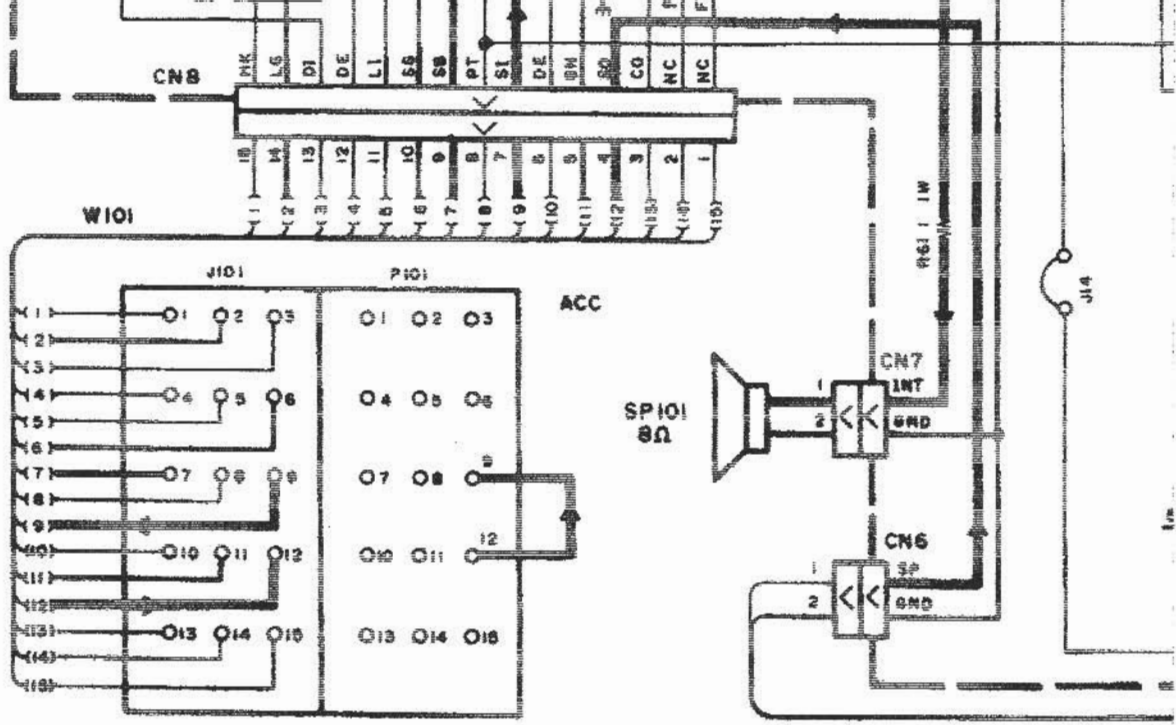

KEN WOOD TKR.720/820



one company > a world of innovation

This document was generated on 09/10/2009

PLEASE CHECK WWW.MOLEX.COM FOR LATEST PART INFORMATION

Part Number: **0003062151**
 Status: **Active**
 Overview: **Standard .062"**
 Description: **1.57mm (.062") Diameter Standard .062 Pin and Socket Plug Housing, 15 Circuits, With Standard Mounting Ears**

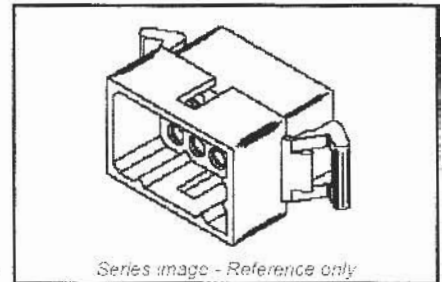

Documents:
 3D Model [Product Specification PS-02-06 \(PDF\)](#)
 Packaging Specification (PDF) [Related Catalog Page \(PDF\)](#)
 Drawing (PDF)

General
 Product Family Crimp Housings
 Series 1625
 Comments Polarized to Mating Part
 Overview Standard .062"
 Product Name Standard .062"

Physical
 Breakaway No
 Circuits (maximum) 15
 Circuits Detail 3x5
 Color - Resin Natural
 Flammability 94V-2
 Gender Plug
 Glow-Wire Compliant No
 Keying to Mating Part None
 Lock to Mating Part Yes
 Material - Resin Nylon
 Number of Rows 3
 Packaging Type Bag
 Panel Mount Yes
 Pitch - Mating Interface (in) 0.145 In
 Pitch - Mating Interface (mm) 3.68 mm
 Pitch - Term. Interface (in) 0.145 In
 Pitch - Term. Interface (mm) 3.96 mm
 Polarized to Mating Part Yes
 Stackable No
 Temperature Range - Operating -40°C to +105°C

Electrical
 CSA LR19980
 Current - Maximum 5A
 TUV R75142
 UL E29179

Material Info
 Old Part Number 1625-15P

Reference - Drawing Numbers
 Product Specification PS-02-06
 Sales Drawing SD-1625-15*

EU RoHS
 ELV and RoHS Compliant
REACH SVHC
 Contains SVHC: No

China RoHS



Need more information on product environmental compliance?

Email productcompliance@molex.com
Please visit the [Contact Us](#) section for any non-product compliance questions.

HFLH Not Reviewed

Search Parts in this Series
 1625 Series

Mates With
 1625 Receptacle

Use With
 Female Crimp Terminals [1561](#)[Link:4559](#)
[.4529](#), [2190](#), [2189](#), [1787](#), [1855](#). Male
 Crimp Terminals [1560](#), [1786](#), [1854](#), [1778](#)
 Male PC Tail Terminals, [1779](#) Female PC
 Tail Terminals

This document was generated on 09/10/2009

PLEASE CHECK WWW.MOLEX.COM FOR LATEST PART INFORMATION

PLEASE CHECK WWW.MOLEX.COM FOR LATEST PART INFORMATION

Part Number: **0003062152**
 Status: **Active**
 Overview: **Standard .062"**
 Description: **1.57mm (.062") Diameter Standard .062 Pin and Socket Plug Housing, 15 Circuits, Without Mounting Ears**

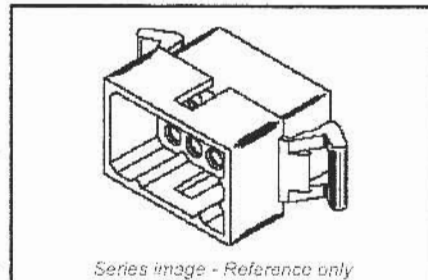

Documents:

3D Model	Product Specification PS-02-06 (PDF)
Packaging Specification (PDF)	Related Catalog Page (PDF)
Drawing (PDF)	

General

Product Family	Crimp Housings
Series	1625
Comments	Polarized to Mating Part
Overview	Standard .062"
Product Name	Standard .062"

Physical

Breakaway	No
Circuits (maximum)	15
Circuits Detail	3x5
Color - Resin	Natural
Flammability	94V-2
Gender	Plug
Glow-Wire Compliant	No
Keying to Mating Part	None
Lock to Mating Part	Yes
Material - Resin	Nylon
Number of Rows	3
Packaging Type	Bag
Panel Mount	No
Pitch - Mating Interface (in)	0.145 In
Pitch - Mating Interface (mm)	3.68 mm
Pitch - Term. Interface (in)	0.145 In
Pitch - Term. Interface (mm)	3.96 mm
Polarized to Mating Part	Yes
Stackable	No
Temperature Range - Operating	-40°C to +105°C

Electrical

CSA	LR19980
Current - Maximum	5A
UL	E29179

Material Info

Old Part Number	1625-15P1
-----------------	-----------

Reference - Drawing Numbers

Product Specification	PS-02-06
Sales Drawing	SD-1625-15*

EU RoHS

ELV and RoHS
Compliant

REACH SVHC

Contains SVHC: No

China RoHS



Need more information on product environmental compliance?

Email productcompliance@molex.com
Please visit the [Contact Us](#) section for any non-product compliance questions.

HFLH

Not Reviewed

Search Parts in this Series

1625 Series

Mates With

1625 Receptacle

Use With

Female Crimp Terminals [1561](#)[Link:4559](#)
, [4529](#), [2190](#), [2189](#), [1787](#), [1855](#) - Male
Crimp Terminals [1560](#), [1786](#), [1854](#), [1778](#)
Male PC Tail Terminals, [1779](#) Female PC
Tail Terminals

PLEASE CHECK WWW.MOLEX.COM FOR LATEST PART INFORMATION

Part Number: **0003062157**
 Status: **Active**
 Overview: **Standard .062"**
 Description: **1.57mm (.062") Diameter Standard .062 Pin and Socket Receptacle Housing, 15 Circuits, With Standard Mounting Ears, Positive Lock**

Documents:

[Drawing \(PDF\)](#) [Product Specification PS-02-06 \(PDF\)](#)
[Packaging Specification \(PDF\)](#) [Related Catalog Page \(PDF\)](#)

General

Product Family: Crimp Housings
 Series: **1625**
 Comments: Polarized to Mating Part
 Overview: **Standard .062"**
 Product Name: **Standard .062"**

Physical

Breakaway: No
 Circuits (maximum): 15
 Circuits Detail: 3x5
 Color - Resin: Natural
 Flammability: 94V-2
 Gender: Receptacle
 Glow-Wire Compliant: No
 Keying to Mating Part: None
 Lock to Mating Part: Yes
 Material - Resin: Nylon
 Number of Rows: 3
 Packaging Type: Bag
 Panel Mount: Yes
 Pitch - Mating Interface (in): 0.145 in
 Pitch - Mating Interface (mm): 3.68 mm
 Pitch - Term. Interface (in): 0.145 in
 Pitch - Term. Interface (mm): 3.96 mm
 Polarized to Mating Part: Yes
 Ports: 1
 Stackable: No
 Temperature Range - Operating: -40°C to +105°C

Electrical

CSA: LR19980
 Current - Maximum: 4A
 TUV: R75142
 UL: E29179

Material Info

Old Part Number: 1625-15P7

Reference - Drawing Numbers

Product Specification: PS-02-06
 Sales Drawing: SD-1625-15*7*

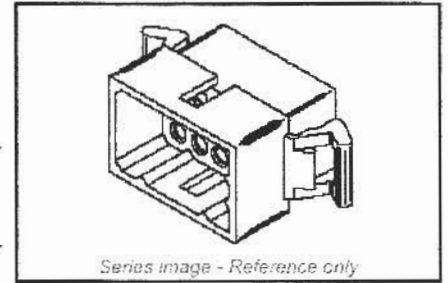

EU RoHS

ELV and RoHS Compliant

REACH SVHC

Contains SVHC: No

China RoHS



Need more information on product environmental compliance?

Email productcompliance@molex.com
 Please visit the [Contact Us](#) section for any non-product compliance questions.

Search Parts in this Series

1625 Series

Mates With

1625 Plug

Use With

Female Crimp Terminals [1561](#)[Link:4559](#), [4529](#), [2190](#), [2189](#), [1787](#), [1855](#). Male Crimp Terminals [1560](#), [1786](#), [1854](#), [1778](#). Male PC Tail Terminals. [1779](#) Female PC Tail Terminals

PLEASE CHECK WWW.MOLEX.COM FOR LATEST PART INFORMATION

Part Number: **0003066155**
 Status: **Active**
 Overview: **Standard .062"**
 Description: **1.57mm (.062") Diameter Standard .062 Pin and Socket Receptacle Housing, 15 Circuits, With Pre-bent Mounting Ears**

Documents:

[3D Model](#)
[Packaging Specification \(PDF\)](#)
[Drawing \(PDF\)](#)
[Product Specification PS-02-06 \(PDF\)](#)
[Related Catalog Page \(PDF\)](#)

General

Product Family: Crimp Housings
 Series: 1625
 Comments: Polarized to Mating Part
 Overview: **Standard .062"**
 Product Name: Standard .062"

Physical

Breakaway: No
 Circuits (maximum): 15
 Circuits Detail: 3x5
 Color - Resin: Natural
 Flammability: 94V-2
 Gender: Receptacle
 Glow-Wire Compliant: No
 Keying to Mating Part: None
 Lock to Mating Part: Yes
 Material - Resin: Nylon
 Number of Rows: 3
 Packaging Type: Bag
 Panel Mount: Yes
 Pitch - Mating Interface (in): 0.145 In
 Pitch - Mating Interface (mm): 3.68 mm
 Pitch - Term. Interface (in): 0.145 In
 Pitch - Term. Interface (mm): 3.96 mm
 Polarized to Mating Part: Yes
 Stackable: No
 Temperature Range - Operating: -40°C to +105°C

Electrical

CSA: LR19980
 Current - Maximum: 5A
 TUV: R75142
 UL: E29179

Material Info

Old Part Number: 1625-15R2

Reference - Drawing Numbers

Product Specification: PS-02-06
 Sales Drawing: SD-1625-15*

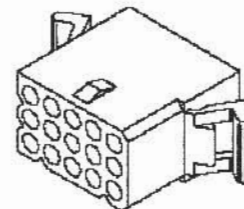

Series image - Reference only

EU RoHS

ELV and RoHS
 Compliant

REACH SVHC

Contains SVHC: No

China RoHS



Need more information on product
 environmental compliance?

Email productcompliance@molex.com
 Please visit the [Contact Us](#) section for any
 non-product compliance questions.

HFLH

Not Reviewed

Search Parts in this Series

1625 Series

Mates With

1625 Plug

Use With

Female Crimp Terminals 1561Link:4559
 , 4529 , 2190 , 2189 , 1787 , 1855 . Male
 Crimp Terminals 1560 , 1786 , 1854 , 1778
 Male PC Tail Terminals. 1779 Female PC
 Tail Terminals

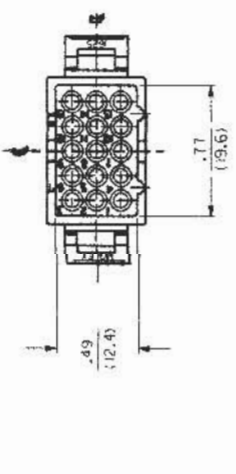

OPTIONAL MOUNTING EAR
(2 PL.) PRESENT EAR SHOWN
SEE DETAIL 1 OR 2

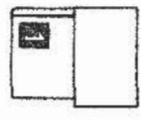
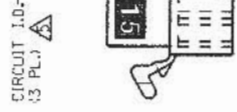
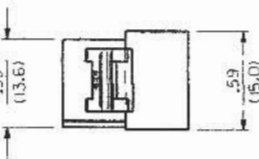

MTC. EAR NOT SHOWN
FOR CKT. I.D. CLARITY

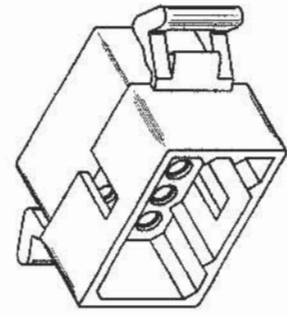
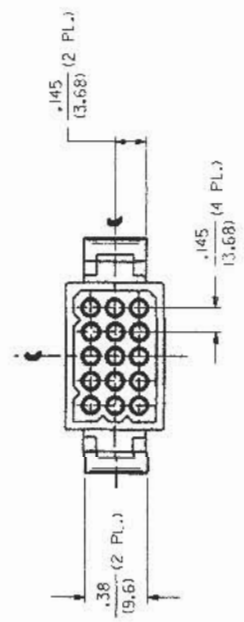
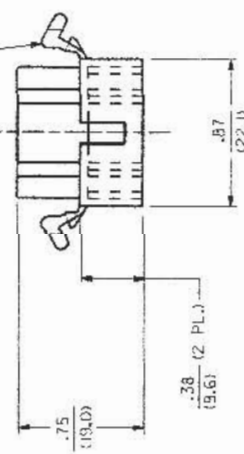

PLUG HOUSING

CHART AND NOTES ON SHEET 3

REVISIONS		REV. NO.		DATE	
1	D2	1	1	1/15/88	
2	D2	2	1	1/15/88	
3	D2	3	1	1/15/88	

TITLE		DRAWN		CHECKED	
.062/11571 HOUSING; PLUG AND RECEPTACLE 15 CKT. (145/13.68) CIR.		R.W.		C.P.	
MATERIAL		SCALE		SHEET NO.	
MOLEX INCORPORATED		2:1		50-1625-15	
MATERIAL SPEC. NO.		MATERIAL		MATERIAL	
100-10000		100-10000		100-10000	
REV. NO.		REV. NO.		REV. NO.	
1.0		1.0		1.0	
DATE		DATE		DATE	
1/15/88		1/15/88		1/15/88	

02	REVISION	ECN #171071	1625
01	FINAL REL. DESG	9/2/82 JRM/AG	
0	REVISE PER	6-22-85 RW	
P	REVISE PER	CC 1/12/94 RW	
0	REVISE PER	CC 6/5/92 RW	
N	REVISE PER	CC 11/20/91 RW	
M	REVISE PER	CC 10/28/91 RW	
L	REMOVED FROM FROM	CC 9/20/91 RW	
K	ADDED B. FINAL REL.	CC 8/20/91 RW	
J	ADDED OPTIONS	CC 8/20/91 RW	
H	REV. B. REDESIGN	CC 8/20/91 RW	
G	REV. A. REDESIGN	CC 8/20/91 RW	
F	REV. C. REDESIGN	CC 8/20/91 RW	
E	REV. D. REDESIGN	CC 8/20/91 RW	
D	REV. E. REDESIGN	CC 8/20/91 RW	
C	REV. F. REDESIGN	CC 8/20/91 RW	
B	REV. G. REDESIGN	CC 8/20/91 RW	
A	REV. H. REDESIGN	CC 8/20/91 RW	

PLUG	
PART NO.	ENG. NO.
03-06-2151/A	625-15P
03-06-7153/A	625-15PBK
03-06-7154/A	625-15PBI
03-06-7154/B	625-15PBL

RECEPTACLE	
PART NO.	ENG. NO.
03-06-1152	625-15R1
03-06-6152	625-15R BK
03-06-6155	625-15R2
NOT TOOLED	
03-06-2152	625-15R2BK

PLUG LEGEND:

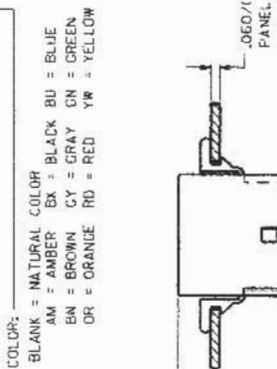

COLOR:
 BLANK = NATURAL COLOR
 AM = AMBER BK = BLACK BU = BLUE
 BN = BROWN CY = GRAY GN = GREEN
 OR = ORANGE RD = RED YW = YELLOW

RECEPTACLE LEGEND:

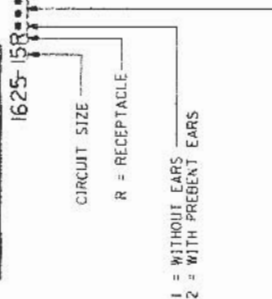

COLOR:
 BLANK = NATURAL COLOR
 AM = AMBER BK = BLACK BU = BLUE
 BN = BROWN CY = GRAY GN = GREEN
 OR = ORANGE RD = RED YW = YELLOW

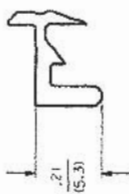

DETAIL 1

STANDARD MOUNTING EAR
 SCALE 4:1

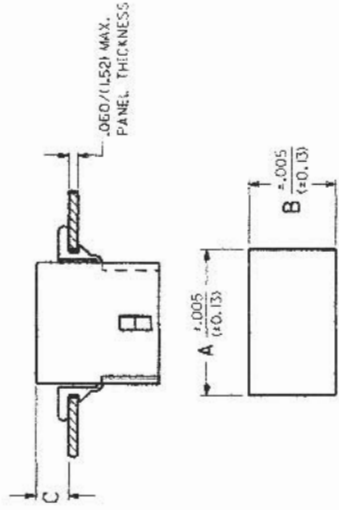

RECOMMENDED HOLE PATTERN

RECEP.	PLUG	PART	REC'D	DATE	BY	CHK'D	DATE	BY
02	01	01	02	03	04	05	06	07
03	04	05	06	07	08	09	10	11
04	05	06	07	08	09	10	11	12
05	06	07	08	09	10	11	12	13
06	07	08	09	10	11	12	13	14
07	08	09	10	11	12	13	14	15
08	09	10	11	12	13	14	15	16
09	10	11	12	13	14	15	16	17
10	11	12	13	14	15	16	17	18
11	12	13	14	15	16	17	18	19
12	13	14	15	16	17	18	19	20
13	14	15	16	17	18	19	20	21
14	15	16	17	18	19	20	21	22
15	16	17	18	19	20	21	22	23
16	17	18	19	20	21	22	23	24
17	18	19	20	21	22	23	24	25
18	19	20	21	22	23	24	25	26
19	20	21	22	23	24	25	26	27
20	21	22	23	24	25	26	27	28
21	22	23	24	25	26	27	28	29
22	23	24	25	26	27	28	29	30
23	24	25	26	27	28	29	30	31
24	25	26	27	28	29	30	31	32
25	26	27	28	29	30	31	32	33
26	27	28	29	30	31	32	33	34
27	28	29	30	31	32	33	34	35
28	29	30	31	32	33	34	35	36
29	30	31	32	33	34	35	36	37
30	31	32	33	34	35	36	37	38
31	32	33	34	35	36	37	38	39
32	33	34	35	36	37	38	39	40
33	34	35	36	37	38	39	40	41
34	35	36	37	38	39	40	41	42
35	36	37	38	39	40	41	42	43
36	37	38	39	40	41	42	43	44
37	38	39	40	41	42	43	44	45
38	39	40	41	42	43	44	45	46
39	40	41	42	43	44	45	46	47
40	41	42	43	44	45	46	47	48
41	42	43	44	45	46	47	48	49
42	43	44	45	46	47	48	49	50
43	44	45	46	47	48	49	50	51
44	45	46	47	48	49	50	51	52
45	46	47	48	49	50	51	52	53
46	47	48	49	50	51	52	53	54
47	48	49	50	51	52	53	54	55
48	49	50	51	52	53	54	55	56
49	50	51	52	53	54	55	56	57
50	51	52	53	54	55	56	57	58
51	52	53	54	55	56	57	58	59
52	53	54	55	56	57	58	59	60
53	54	55	56	57	58	59	60	61
54	55	56	57	58	59	60	61	62
55	56	57	58	59	60	61	62	63
56	57	58	59	60	61	62	63	64
57	58	59	60	61	62	63	64	65
58	59	60	61	62	63	64	65	66
59	60	61	62	63	64	65	66	67
60	61	62	63	64	65	66	67	68
61	62	63	64	65	66	67	68	69
62	63	64	65	66	67	68	69	70
63	64	65	66	67	68	69	70	71
64	65	66	67	68	69	70	71	72
65	66	67	68	69	70	71	72	73
66	67	68	69	70	71	72	73	74
67	68	69	70	71	72	73	74	75
68	69	70	71	72	73	74	75	76
69	70	71	72	73	74	75	76	77
70	71	72	73	74	75	76	77	78
71	72	73	74	75	76	77	78	79
72	73	74	75	76	77	78	79	80
73	74	75	76	77	78	79	80	81
74	75	76	77	78	79	80	81	82
75	76	77	78	79	80	81	82	83
76	77	78	79	80	81	82	83	84
77	78	79	80	81	82	83	84	85
78	79	80	81	82	83	84	85	86
79	80	81	82	83	84	85	86	87
80	81	82	83	84	85	86	87	88
81	82	83	84	85	86	87	88	89
82	83	84	85	86	87	88	89	90
83	84	85	86	87	88	89	90	91
84	85	86	87	88	89	90	91	92
85	86	87	88	89	90	91	92	93
86	87	88	89	90	91	92	93	94
87	88	89	90	91	92	93	94	95
88	89	90	91	92	93	94	95	96
89	90	91	92	93	94	95	96	97
90	91	92	93	94	95	96	97	98
91	92	93	94	95	96	97	98	99
92	93	94	95	96	97	98	99	100

NOTES:

- MATERIAL: NYLON TYPE 6/6, 94V-2.
- THIS PART COMPLIES WITH MOLEX PRODUCT SPEC. 02-06.
- THIS HOUSING FOR USE WITH .062/(1.57) DIA. TERMINALS.
- WHERE DENOTED IN CHART, TOOLS ARE BUILT WITH PREBENT MOUNTING EARS PER DETAIL 2 AND SUPERSEDE ALL TOOLS PREVIOUSLY BUILT WITH THE STANDARD MOUNTING EARS.
- CIRCUIT I.D. NUMBERS ON HOUSING APPEAR ON PART FROM TOOLS BUILT AFTER 1/15/94.

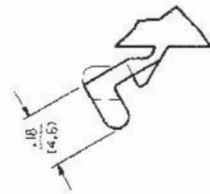
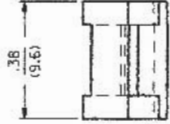

REV.	DATE	DESCRIPTION	BY	CHK'D
1	7/18/88	MOLEX INCORPORATED		
2				
3				
4				
5				
6				
7				
8				
9				
10				
11				
12				
13				

SEE CHART
 SD-1625-15

REVISIONS

REV. 1 2 3 4 5 6 7 8 9 10 11 12 13



ELECTRONICS, INC.
 44 FARRAND STREET
 BLOOMFIELD, NJ 07003
 (973) 748-5089

25B951

NTE2547 (NPN) & NTE2548 (PNP)
Silicon Complementary Transistors
Darlington Driver

Features:

- High DC Current Gain
- High Current Capacity and Wide ASO
- Low Saturation Voltage

Applications:

- Motor Drivers
- Printer Hammer Drivers
- Relay Drivers
- Voltage Regulator Control

Absolute Maximum Ratings: ($T_A = +25^\circ\text{C}$ unless otherwise specified)

Collector to Base Voltage, V_{CBO}	110V
Collector to Emitter Voltage, V_{CEO}	100V
Emitter to Base Voltage, V_{EBO}	6V
Collector Current, I_C	
Continuous	8A
Peak	12A
Collector Dissipation, P_C	
$T_A = +25^\circ\text{C}$	2.0W
$T_C = +25^\circ\text{C}$	30W
Operating Junction Temperature, T_J	+150°C
Storage Temperature Range, T_{stg}	-55° to +150°C

Electrical Characteristics: ($T_A = +25^\circ\text{C}$ unless otherwise specified)

Parameter	Symbol	Test Conditions	Min	Typ	Max	Unit
Collector Cutoff Current	I_{CBO}	$V_{CB} = 80V, I_E = 0$	-	-	0.1	mA
Emitter Cutoff Current	I_{EBO}	$V_{EB} = 5V, I_C = 0$	-	-	3.0	mA
DC Current Gain	h_{FE}	$V_{CE} = 3V, I_C = 4A$	1500	4000		
Gain Bandwidth Product	f_T	$V_{CE} = 5V, I_C = 4A$	-	20	-	MHz

Electrical Characteristics (Cont'd): ($T_A = +25^\circ\text{C}$ unless otherwise specified)

Parameter	Symbol	Test Conditions	Min	Typ	Max	Unit
Collector to Emitter Saturation Voltage NTE2547	$V_{CE(sat)}$	$I_C = 4\text{A}, I_B = 8\text{mA}$	-	0.9	1.5	V
NTE2548			-	1.0	-	V
Base to Emitter Saturation Voltage	$V_{BE(sat)}$	$I_C = 4\text{A}, I_B = 8\text{mA}$	-	-	2.0	V
Collector-Base Breakdown Voltage	$V_{(BR)CBO}$	$I_C = 5\text{mA}, I_E = 0$	110	-	-	V
Collector-Emitter Breakdown Voltage	$V_{(BR)CEO}$	$I_C = 50\text{mA}, R_{BE} = \infty$	100	-	-	V
Turn-On Time NTE2547	t_{on}	$I_C = 4\text{A}, I_{B1} = 500\text{mA}, I_{B2} = -500\text{mA},$ Pulse Width = $50\mu\text{s},$ Duty Cycle $\leq 1\%$, Note 1	-	0.6	-	μs
NTE2548			-	0.7	-	μs
Storage Time NTE2547	t_{stg}		-	4.8	-	μs
NTE2548			-	1.4	-	μs
Fall Time NTE2547	t_f		-	1.6	-	μs
NTE2548			-	1.5	-	μs

Note 1. For NTE2548 (PNP), the polarity is reversed.

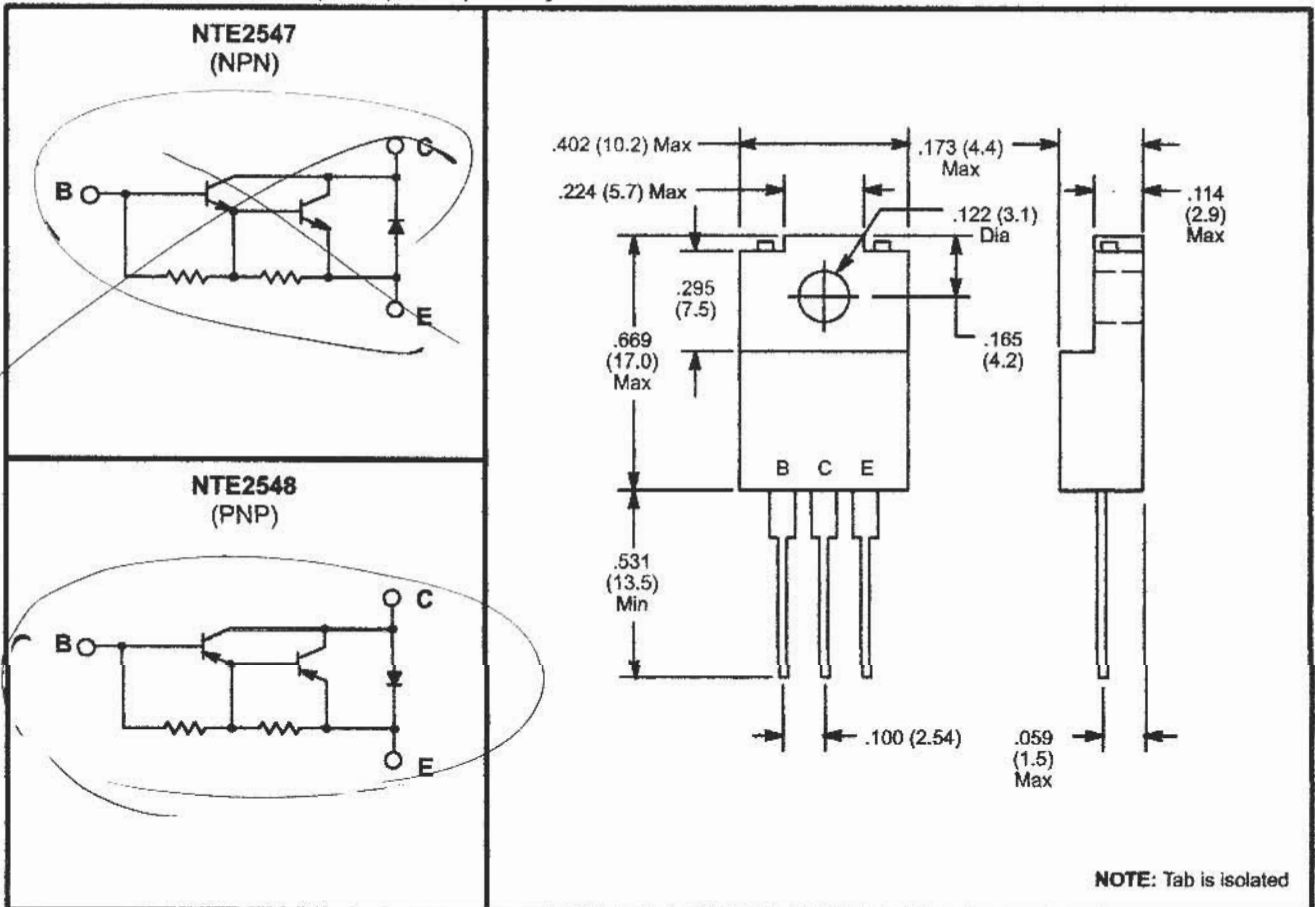



ELECTRONICS, INC.
 44 FARRAND STREET
 BLOOMFIELD, NJ 07003
 (973) 748-5089

2N3055
 2N3771
 2N3772
 2N5885

} NTE 181

NTE180 (PNP) & NTE181 (NPN)
Silicon Power Transistor
High Power Audio Amplifier

Description:

The NTE180 (PNP) and NTE181 (NPN) are silicon complementary transistors in a TO3 type case designed for use as output devices in complementary audio amplifiers to 100 watts music power per channel.

Features:

- High DC Current Gain: $h_{FE} = 25 - 100 @ I_C = 7.5A$
- Excellent Safe Operating Area

Absolute Maximum Ratings:

Collector–Emitter Voltage, V_{CER}	100V
Collector–Base Voltage, V_{CB}	100V
Collector–Emitter Voltage, V_{CEO}	90V
Emitter–Base Voltage, V_{EB}	4V
Collector Current, I_C	30A
Base Current, I_B	7.5A
Total Device Dissipation ($T_C = +25^\circ C$), P_D	200W
Derate Above $25^\circ C$	1.14W/ $^\circ C$
Operating Junction Temperature Range, T_J	-65° to $+200^\circ C$
Storage Temperature Range, T_{stg}	-65° to $+200^\circ C$
Thermal Resistance, Junction–to–Case, R_{thJC}	0.875 $^\circ C/W$

Electrical Characteristics: ($T_C = +25^\circ C$ unless otherwise specified)

Parameter	Symbol	Test Conditions	Min	Typ	Max	Unit
OFF Characteristics						
Collector–Emitter Breakdown Voltage	$V_{(BR)CER}$	$I_C = 200mA, R_{BE} = 100\Omega$, Note 1	100	–	–	V
Collector–Emitter Sustaining Voltage	$V_{CEO(sus)}$	$I_C = 200mA$, Note 1	90	–	–	V
Collector–Base Cutoff Current	I_{CBO}	$V_{CB} = 100V, I_E = 0$	–	–	1.0	mA
		$V_{CB} = 100V, I_E = 0, T_C = +150^\circ C$	–	–	5.0	mA
Emitter–Base Cutoff Current	I_{EBO}	$V_{BE} = 4V, I_C = 0$	–	–	1.0	mA

Note 1. Pulse Test: Pulse Width $\leq 300\mu s$. Duty Cycle $\leq 2\%$.

Electrical Characteristics (Cont'd): ($T_C = +25^\circ\text{C}$ unless otherwise specified)

Parameter	Symbol	Test Conditions	Min	Typ	Max	Unit
ON Characteristics (Note 1)						
DC Current Gain	h_{FE}	$I_C = 7.5\text{A}, V_{CE} = 2\text{V}$	25	—	100	
Base–Emitter ON Voltage	$V_{BE(on)}$	$I_C = 7.5\text{A}, V_{CE} = 2\text{V}$	—	—	1.3	V
Collector–Emitter Saturation Voltage	$V_{CE(sat)}$	$I_C = 7.5\text{A}, I_B = 750\text{mA}$	—	—	0.8	V
Base–Emitter Saturation Voltage	$V_{BE(sat)}$	$I_C = 7.5\text{A}, I_B = 750\text{mA}$	—	—	1.3	V
Dynamic Characteristics						
Current Gain–Bandwidth Product	f_T	$I_C = 1\text{A}, V_{CE} = 10\text{V}, f = 1\text{MHz}$	2.0	—	—	MHz

Note 1. Pulse Test: Pulse Width $\leq 300\mu\text{s}$. Duty Cycle $\leq 2\%$.

Note 2. NTE181MP is a matched pair of NTE181 with their DC Current Gain (h_{FE}) matched to within 10% of each other.

Note 3. NTE180MCP is a matched complementary pair containing 1 each of NTE180 (PNP) and NTE181 (NPN).

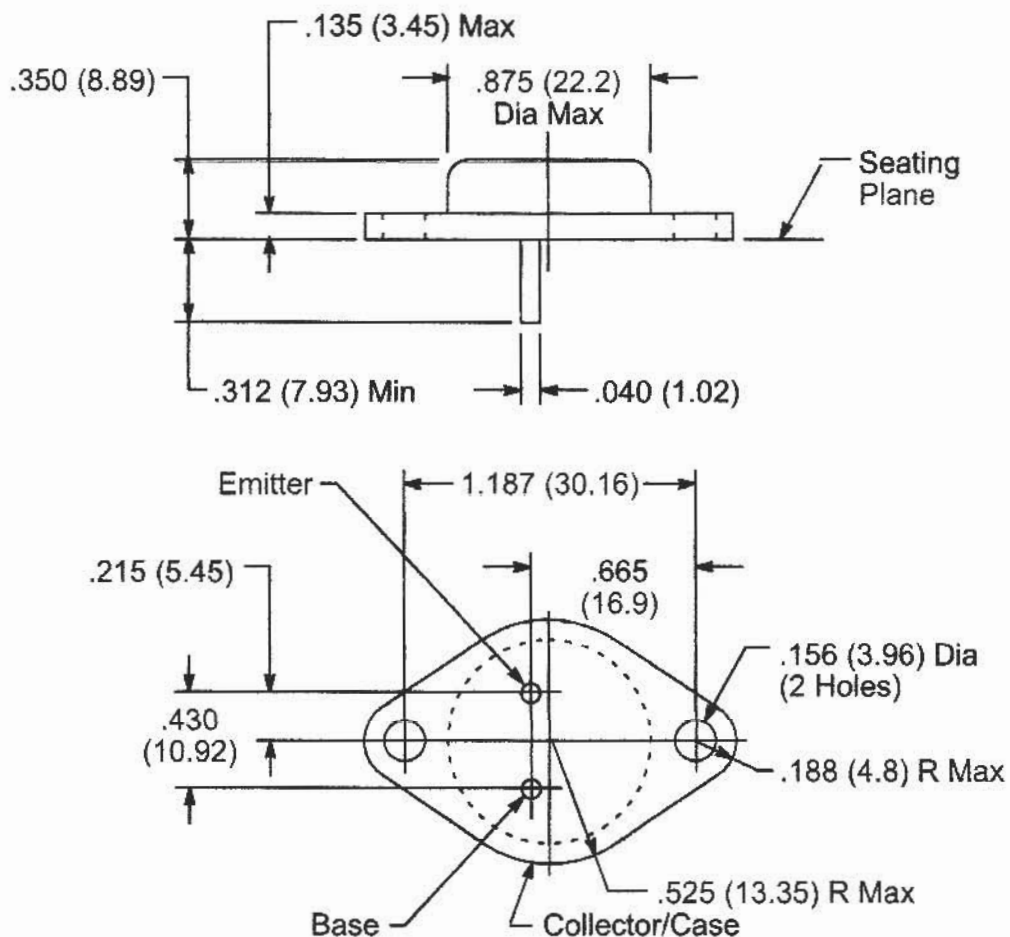

- (D1) 1B2C1 - TOSHIBA ($\frac{1}{2}$ WAVE TO RIBB) GOOD X
- (Q5) 2N5885
- (Q6) 2N5885
- (Q4) 2SB968(Q)
- (Q1) 25C2712(Y)
- (Q2) " "
- (Q3) " "
- (D5) RD7.5E(B2)
- (D4) 1SS181
- (D6) 1SS181
- (D101) 525VB10 - GOOD X

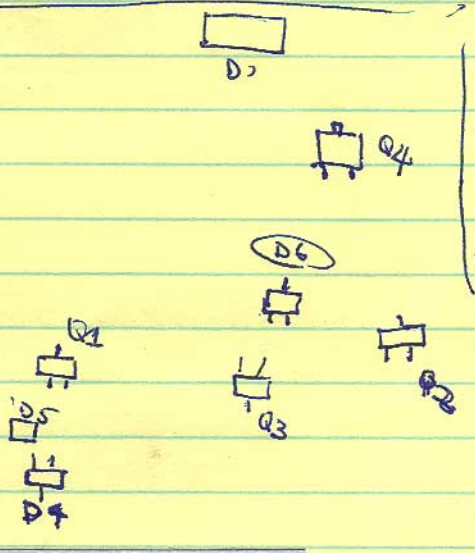

25C2694
 REPLACED BY
 25C2782
 \$32.00



ELECTRONICS, INC.
 44 FARRAND STREET
 BLOOMFIELD, NJ 07003
 (973) 748-5089
<http://www.nteinc.com>

NTE352 Silicon NPN Transistor RF Power Amp, Driver

Description:

The NTE352 is a 12.5V Class C epitaxial silicon NPN transistor in a W65 type package designed primarily for VHF, FM communications. Diffused emitter resistors provide high VSWR capability under rated operating conditions. Internal impedance matching ensures optimum power gain and efficiency over the 136–175MHz band.

Features:

- 175MHz
- 12.5 Volts
- P_{OUT} = 100 Watts
- G_P = 6.0dB Minimum
- Common Emitter Configuration

Absolute Maximum Ratings: (T_C = +25°C unless otherwise specified)

Collector–Base Voltage, V _{CBO}	36V
Collector–Emitter Voltage, V _{CEO}	18V
Collector–Emitter Voltage, V _{CES}	36V
Emitter–Base Voltage, V _{EBO}	4V
Collector Current (Peak), I _C	20A
Power Dissipation, P _D	270W
Operatin Junction Temperature, T _J	+200°C
Storage Temperature Range, T _{stg}	–65° to +150°C
Thermal Resistance, Junction–to–Case, R _{thJC}	0.65°C/W

Electrical Characteristics: (T_C = +25°C unless otherwise specified)

Parameter	Symbol	Test Conditions	Min	Typ	Max	Unit
Static Characteristics						
Collector–Base Breakdown Voltage	V _{(BR)CBO}	I _C = 50mA, I _E = 0	36	–	–	V
Collector–Emitter Breakdown Voltage	V _{(BR)CES}	I _C = 100mA, V _{BE} = 0	36	–	–	V
	V _{(BR)CEO}	I _C = 100mA, I _B = 0	18	–	–	V
Emitter–Base Breakdown Voltage	V _{(BR)EBO}	I _E = 10mA, I _C = 0	4	–	–	V
Collector Cutoff Current	I _{CES}	V _{CE} = 15V, I _E = 0	–	–	15	mA
ON Characteristics						
DC Current Gain	h _{FE}	I _C = 5A, V _{CE} = 5V	10	75	150	

Electrical Characteristics (Cont'd): ($T_C = +25^\circ\text{C}$ unless otherwise specified)

Parameter	Symbol	Test Conditions	Min	Typ	Max	Unit
Dynamic Characteristics						
Output Power	P_{OUT}	$V_{CC} = 12.5\text{V}, f = 175\text{MHz},$ $P_{IN} = 25\text{W}$	100	-	-	W
Power Gain	G_{PE}		6.0	-	-	dB
Output Capacitance	C_{ob}	$V_{CB} = 12.5\text{V}, f = 1\text{MHz}$	-	-	390	pF
Impedance Data						
Input Impedance	Z_{IN}	$f = 175\text{MHz}$	1.5 - j0.9			Ω
Clamping Impedance	Z_{CL}	$f = 175\text{MHz}$	0.5 - j1.0			Ω

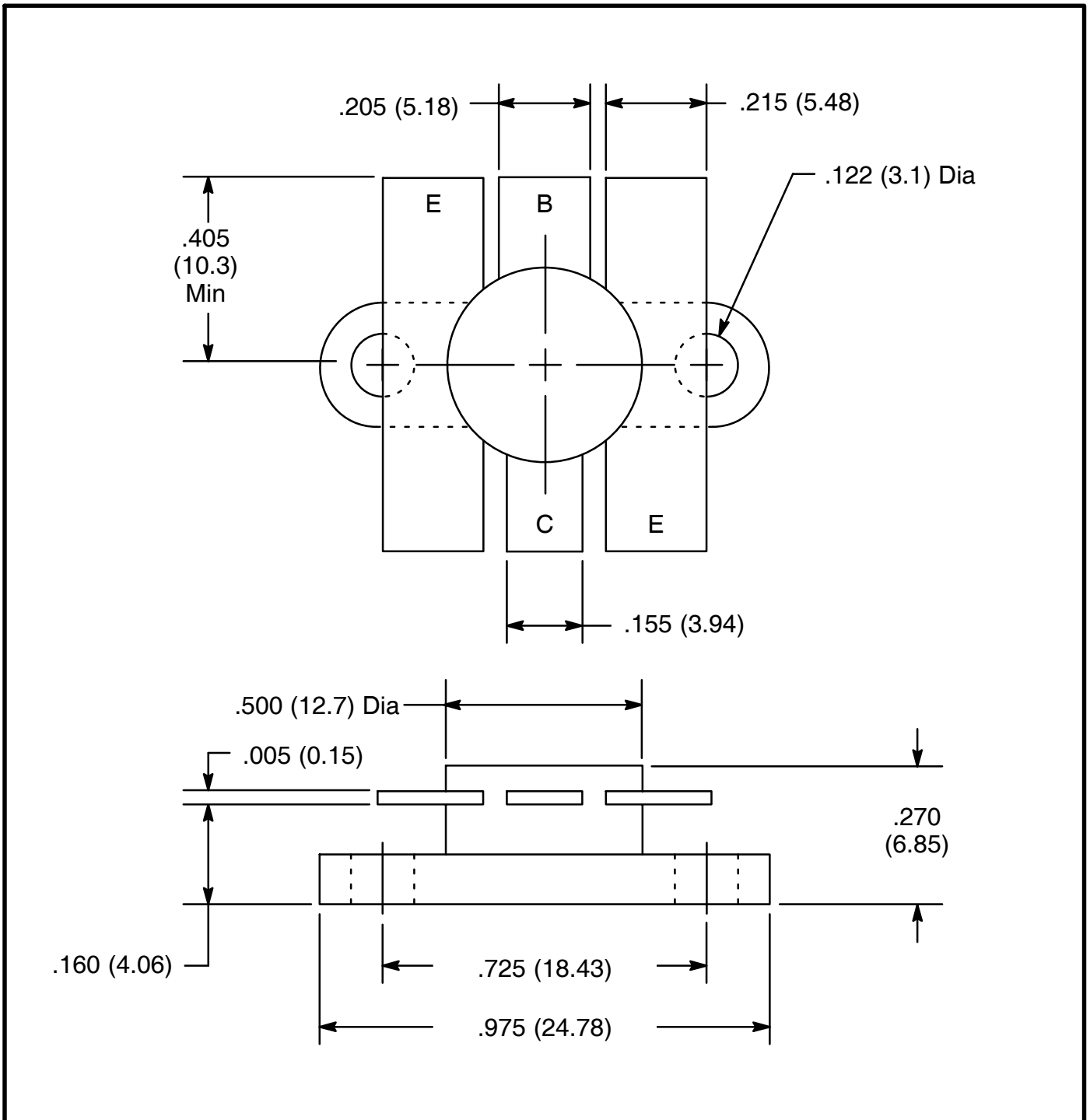

TOSHIBA TRANSISTOR SILICON NPN EPITAXIAL PLANAR TYPE

2SC2782

VHF BAND POWER AMPLIFIER APPLICATIONS

Unit in mm

- Output Power : $P_o = 80W$ (Min.)
($f = 175MHz$, $V_{CC} = 12.5V$, $P_i = 18W$)

MAXIMUM RATINGS ($T_c = 25^\circ C$)

CHARACTERISTIC	SYMBOL	RATING	UNIT
Collector-Base Voltage	V_{CBO}	36	V
Collector-Emitter Voltage	V_{CEO}	16	V
Emitter-Base Voltage	V_{EBO}	4	V
Collector Current	I_C	20	A
Collector Power Dissipation	P_C	220	W
Junction Temperature	T_j	175	$^\circ C$
Storage Temperature Range	T_{stg}	-65~175	$^\circ C$

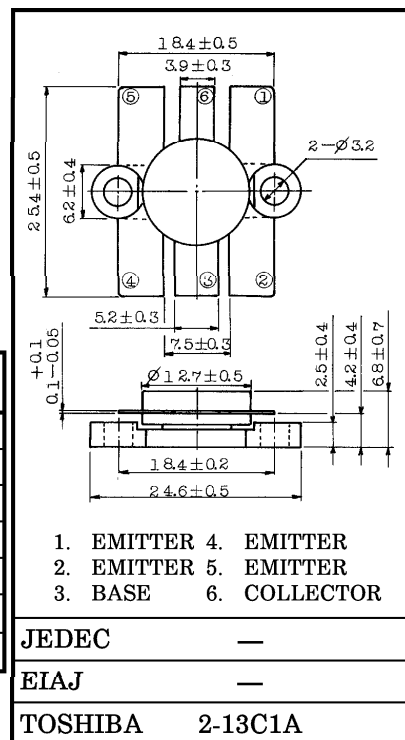

ELECTRICAL CHARACTERISTICS ($T_c = 25^\circ C$)

Weight : 5.5g

CHARACTERISTIC	SYMBOL	TEST CONDITION	MIN.	TYP.	MAX.	UNIT
Collector-Base Breakdown Voltage	$V_{(BR)CBO}$	$I_C = 20mA, I_E = 0$	36	—	—	V
Collector-Emitter Breakdown Voltage	$V_{(BR)CEO}$	$I_C = 50mA, I_B = 0$	16	—	—	V
Emitter-Base Breakdown Voltage	$V_{(BR)EBO}$	$I_E = 1mA, I_C = 0$	4	—	—	V
DC Current Gain	h_{FE}	$V_{CE} = 5V, I_C = 10A$ *	10	—	—	
Collector Output Capacitance	C_{ob}	$V_{CB} = 12.5V, I_E = 0$ $f = 1MHz$	—	—	320	pF
Output Power	P_o	(Fig.)	80	90	—	W
Power Gain	G_p	$V_{CC} = 12.5V, f = 175MHz$	6.4	6.8	—	dB
Collector Efficiency	η_C	$P_i = 18W$	60	70	—	%
Series Equivalent Input Impedance	Z_{in}	$V_{CC} = 12.5V$	—	1.0 +j1.5	—	Ω
Series Equivalent Output Impedance	Z_{out}	$f = 175MHz, P_o = 80W$	—	1.2 +j1.8	—	Ω

* Pulse Test : Pulse Width $\leq 100\mu s$, Duty Cycle $\leq 3\%$

CAUTION

Beryllia Ceramics is used in this product. The dust or vapor can be dangerous to humans. Do not break, cut, crush or dissolve chemically. Dispose of this properly according to law. Do not intermingle with normal industrial or domestic waste.

961001EAA2

TOSHIBA is continually working to improve the quality and the reliability of its products. Nevertheless, semiconductor devices in general can malfunction or fail due to their inherent electrical sensitivity and vulnerability to physical stress. It is the responsibility of the buyer, when utilizing TOSHIBA products, to observe standards of safety, and to avoid situations in which a malfunction or failure of a TOSHIBA product could cause loss of human life, bodily injury or damage to property. In developing your designs, please ensure that TOSHIBA products are used within specified operating ranges as set forth in the most recent products specifications. Also, please keep in mind the precautions and conditions set forth in the TOSHIBA Semiconductor Reliability Handbook.

Fig. P_o TEST CIRCUIT

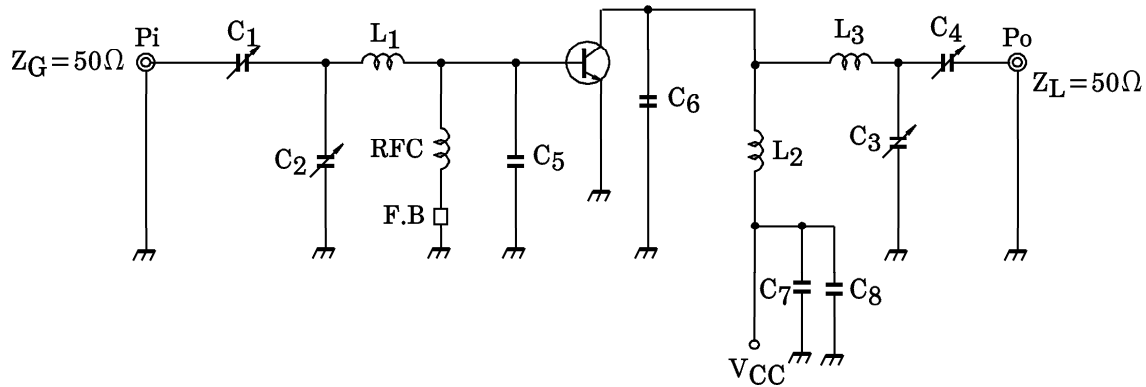

- C₁~C₄ : ~20pF
- C₅ : 156pF (39pF×4) CERAMIC CONDENSER
- C₆ : 132pF (33pF×4) CERAMIC CONDENSER
- C₇ : 0.01μF CERAMIC CONDENSER
- C₈ : 10μF
- L₁, L₃ : φ1.5mm SILVER PLATED COPPER WIRE, 10ID, 1T
- L₂ : φ1.5mm SILVER PLATED COPPER WIRE, 10ID, 2T
- RFC : φ1mm ENAMEL COATED COPPER WIRE, 6ID, 10T
- FB : FERRITE BEAD

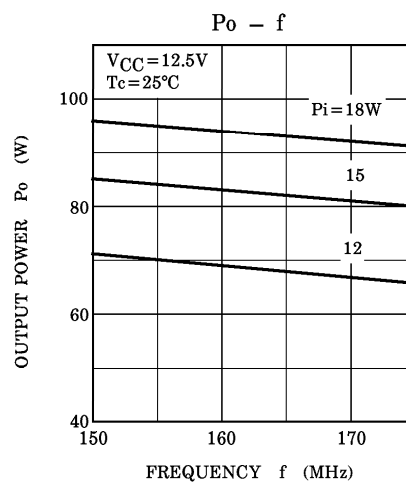
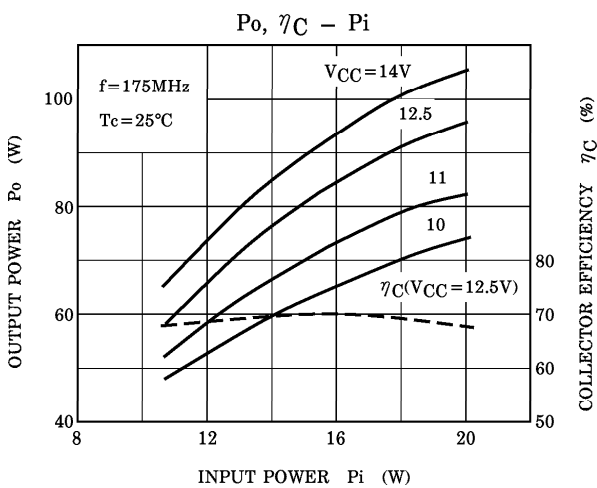

CAUTION

These are only typical curves and devices are not necessarily guaranteed at these curves.

961001EAA2'

- The information contained herein is presented only as a guide for the applications of our products. No responsibility is assumed by TOSHIBA CORPORATION for any infringements of intellectual property or other rights of the third parties which may result from its use. No license is granted by implication or otherwise under any intellectual property or other rights of TOSHIBA CORPORATION or others.
- The information contained herein is subject to change without notice.