

# KENWOOD

## **Document Copyrights**

Copyright 2006 by Kenwood Corporation. All rights reserved.

No part of this manual may be reproduced, translated, distributed, or transmitted in any form or by any means, electronic, mechanical, photocopying, recording, or otherwise, for any purpose without the prior written permission of Kenwood.

## **Disclaimer**

While every precaution has been taken in the preparation of this manual, Kenwood assumes no responsibility for errors or omissions. Neither is any liability assumed for damages resulting from the use of the information contained herein. Kenwood reserves the right to make changes to any products herein at any time for improvement purposes.

UHF FM TRANSCEIVER

# TK-8108

## SERVICE MANUAL

M VERSION

# KENWOOD

© 2002-7 PRINTED IN JAPAN  
B51-8637-00 (S) PDF

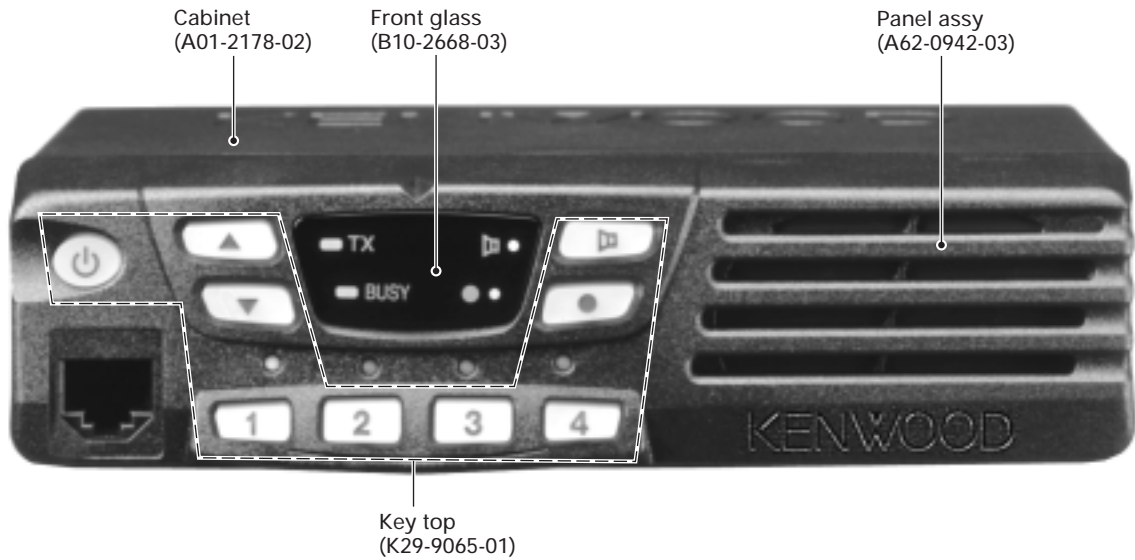

## CONTENTS / GENERAL

### CONTENTS

|   |                   |
|---|-------------------|
| <b>GENERAL</b> .....                    | <b>2</b>          |
| <b>OPERATING FEATURES</b> .....         | <b>4</b>          |
| <b>REALIGNMENT</b> .....                | <b>7</b>          |
| <b>DISASSEMBLY FOR REPAIR</b> .....     | <b>9</b>          |
| <b>CIRCUIT DESCRIPTION</b> .....        | <b>10</b>         |
| <b>SEMICONDUCTOR DATA</b> .....         | <b>15</b>         |
| <b>COMPONENTS DESCRIPTION</b> .....     | <b>16</b>         |
| <b>PARTS LIST</b> .....                 | <b>18</b>         |
| <b>EXPLODED VIEW</b> .....              | <b>24</b>         |
| <b>PACKING</b> .....                    | <b>25</b>         |
| <b>ADJUSTMENT</b> .....                 | <b>26</b>         |
| <b>PC BOARD</b>                         |                   |
| <b>DISPLAY UNIT (X54-3340-20)</b> ..... | <b>31</b>         |
| <b>TX-RX UNIT (X57-6303-01)</b> .....   | <b>33</b>         |
| <b>SCHEMATIC DIAGRAM</b> .....          | <b>39</b>         |
| <b>BLOCK DIAGRAM</b> .....              | <b>43</b>         |
| <b>LEVEL DIAGRAM</b> .....              | <b>45</b>         |
| <b>TERMINAL FUNCTION</b> .....          | <b>47</b>         |
| <b>SPECIFICATIONS</b> .....             | <b>BACK COVER</b> |

### GENERAL

#### INTRODUCTION

##### SCOPE OF THIS MANUAL

This manual is intended for use by experienced technicians familiar with similar types of commercial grade communications equipment. It contains all required service information for the equipment and is current as of this publication date. Changes which may occur after publication are covered by either Service Bulletins or Manual Revisions, which are issued as required.

#### ORDERING REPLACEMENT PARTS

When ordering replacement parts or equipment information, the full part identification number should be included. This applies to all parts : components, kits, and chassis. If the part number is not known, include the chassis or kit number of which it is a part and a sufficient description of the required component for proper identification.

#### PERSONNEL SAFETY

The following precautions are recommended for personnel safety :

- DO NOT transmit if someone is within two feet (0.6 meter) of the antenna.
- DO NOT transmit until all RF connectors are secure and any open connectors are properly terminated.
- SHUT this equipment when near electrical blasting caps or while in an explosive atmosphere.
- All equipment should be properly grounded before power-up for safe operation.
- This equipment should be serviced by only qualified technicians.

#### PRE-INSTALLATION CONSIDERNATIONS

##### 1. UNPACKING

Unpack the radio from its shipping container and check for accessory items. If any item is missing, please contact KENWOOD immediately.

##### 2. LICENSING REQUIREMENTS

Federal regulations require a station license for each radio installation (mobile or base) be obtained by the equipment owner. The licensee is responsible for ensuring transmitter power, frequency, and deviation are within the limits permitted by the station license.

Transmitter adjustments may be performed only by a licensed technician holding an FCC first, second or general class commercial radiotelephone operator's license. There is no license required to install or operate the radio.

## GENERAL

### 3. PRE-INSTALLATION CHECKOUT

#### 3-1. Introduction

Each radio is adjusted and tested before shipment. However, it is recommended that receiver and transmitter operation be checked for proper operation before installation.

#### 3-2. Testing

The radio should be tested complete with all cabling and accessories as they will be connected in the final installation. Transmitter frequency, deviation, and power output should be checked, as should receiver sensitivity, squelch operation, and audio output. Signalling equipment operation should be verified.

### 4. PLANNING THE INSTALLATION

#### 4-1. General

Inspect the vehicle and determine how and where the radio antenna and accessories will be mounted.

Plan cable runs for protection against pinching or crushing wiring, and radio installation to prevent overheating.

#### 4-2. Antenna

The favored location for an antenna is in the center of a large, flat conductive area, usually at the roof center. The trunk lid is preferred, bond the trunk lid and vehicle chassis using ground straps to ensure the lid is at chassis ground.

#### 4-3. Radio

The universal mount bracket allows the radio to be mounted in a variety of ways. Be sure the mounting surface is adequate to support the radio's weight. Allow sufficient space around the radio for air cooling. Position the radio close enough to the vehicle operator to permit easy access to the controls when driving.

#### 4-4. DC Power and wiring

1. This radio may be installed in negative ground electrical systems only. Reverse polarity will cause the cable fuse to blow. Check the vehicle ground polarity before installation to prevent wasted time and effort.
2. Connect the positive power lead directly to the vehicle battery positive terminal. Connecting the Positive lead to any other positive voltage source in the vehicle is not recommended.
3. Connect the ground lead directly to the battery negative terminal.
4. The cable provided with the radio is sufficient to handle the maximum radio current demand. If the cable must be extended, be sure the additional wire is sufficient for the current to be carried and length of the added lead.

### 5. INSTALLATION PLANNING – CONTROL STATIONS

#### 5-1. Antenna system

Control station. The antenna system selection depends on many factors and is beyond the scope of this manual. Your KENWOOD dealer can help you select an antenna system that will best serve your particular needs.

#### 5-2. Radio location

Select a convenient location for your control station radio which is as close as practical to the antenna cable entry point. Secondly, use your system's power supply (which supplies the voltage and current required for your system). Make sure sufficient air can flow around the radio and power supply to allow adequate cooling.

### SERVICE

This radio is designed for easy servicing. Refer to the schematic diagrams, printed circuit board views, and alignment procedures contained in this manual.

### NOTE

If you do not intend to use the 3.5-mm jack for the external speaker, fit the supplied speaker-jack cap to stop dust and sand getting in.

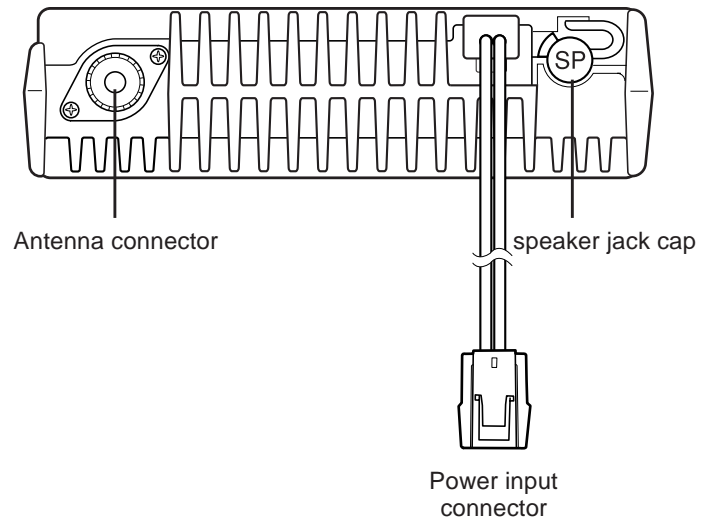

## OPERATING FEATURES

### 1. Controls and Functions

#### 1-1. Front Panel

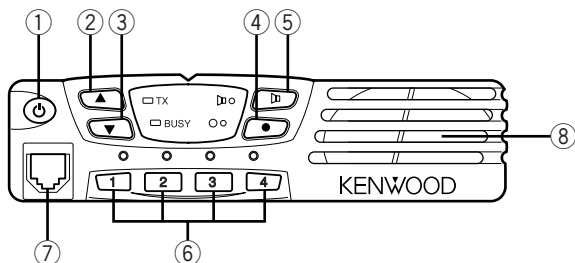

#### 1-2. Microphone

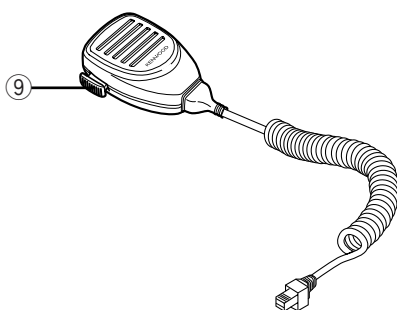

- ① **⏻ (Power) switch**  
Press to switch the transceiver ON. Press and hold for approximately 1 second to switch the transceiver OFF.
- ② **▲ key**  
Press to increase the volume level.
- ③ **▼ key**  
Press to decrease the volume level.
- ④ **● key**  
PF (Programmable Function) key. The default setting of this key is None (no function). The programmable functions available for this key are listed below.
- ⑤ **☐ key**  
PF (Programmable Function) key. The default setting of this key is Monitor (page 10). Other programmable functions available for this key are listed below.
- ⑥ **1 / 2 / 3 / 4 keys**  
Press to select a channel from 1 to 4. When using the Group function, press to select a channel from 5 to 8.
- ⑦ **Microphone jack**  
Insert the microphone plug into this jack (the microphone is an optional accessory).
- ⑧ **Speaker**  
Internal speaker.
- ⑨ **PTT switch**  
Press this switch, then speak into the microphone to call a station.

#### 1-3. Auxiliary Programmable Functions:

- Emergency
- Group
- Key Lock
- Monitor
- None (no function)
- Scan On/ Off
- Talk Around
- Temporary Delete

#### 1-4. Display

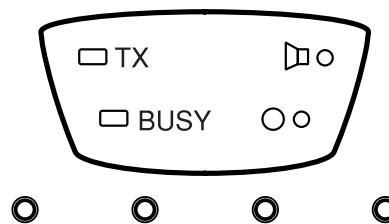

| Indicator | Description   |
|-----------|---|
| □ TX      | Lights while transmitting.  |
| □ BUSY    | Lights when a signal is detected on the currently selected channel.           |
| ☐○        | Lights while the function programmed onto its corresponding key is activated. |
| ○○        | Lights while the function programmed onto its corresponding key is activated. |
| ○ ○ ○ ○   | Lights to display the currently selected channel (1 ~ 4 or 5 ~ 8).            |

#### 1-5. Rear panel

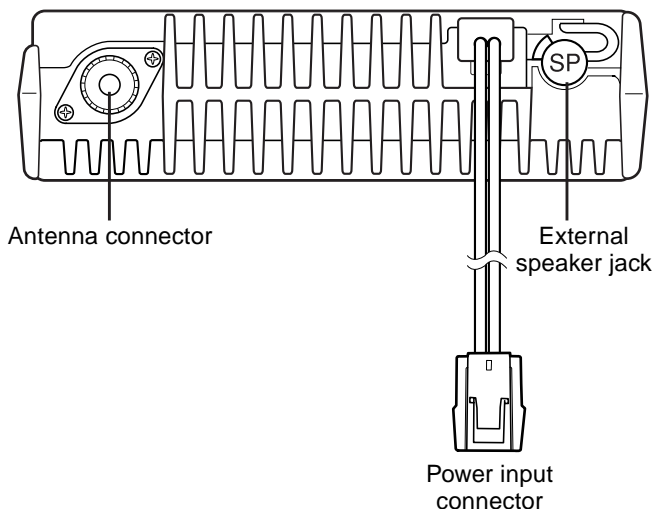

# OPERATING FEATURES

## 2. Operation Features

The TK-8108 is a UHF FM radio designed to operate in conventional format. The programmable features are summarized.

## 3. Transceiver Controls and Indicators

### 3-1. Front Panel Controls

All the keys on the front panel are momentary-type push buttons. The functions of these keys are explained below.

- **POWER key**

Transceiver POWER key. When the power is switched off, all the parameters are stored in memory. When the power is switched on again, the transceiver returns to the previous conditions.

- **CHANNEL Keys**

- **MONITOR key (Programmable)**

- **● key (Programmable)**

- **VOLUME UP/DOWN key**

When the key is pressed, the volume level is increased/decreased and repeats if held for 200ms or longer.

- **BUSY/TX LED**

The BUSY indicator (Green LED) shows that the channel is in use. The TX indicator (Red LED) shows that you are transmitting.

### 3-2. Programmable Keys

The FPU (KPG-70D) enables programmable keys to select the following functions.

- |               |                    |
|---------------|--------------------|
| • Emergency   | • Talk Around      |
| • Key Lock    | • Temporary Delete |
| • Monitor     | • None             |
| • Scan ON/OFF | • Group            |

- **Emergency**

Pressing this key for longer than 1 second causes the transceiver to enter the emergency mode. The transceiver jumps to the programmed "Emergency channel" and transmits for 25\* seconds.

The transceiver disables mic mute while transmitting. After finishing transmission, the transceiver receives for 5\* seconds. The transceiver Mute\* the speaker while receiving. Following the above sequence, the transceiver continues to transmit and receive.

\* Default value

- **Key lock**

Pressing this key causes the transceiver to accept entry of only the [Vol Up/Down]\*, [Key lock], Microphone [PTT], [Monitor], [Emergency], and [Power] keys.

\* Programmable

- **Monitor**

Used to release signalling (press once) or squelch (press and hold for approximately two seconds) when operating as a conventional. It is also used to reset option signalling.

- **Scan ON/OFF**

Press this key starts scanning. Pressing this key stops scanning.

- **Talk around**

Press this key, the transceiver uses the receive frequency and the tone for transmission.

The operator can call the other party directly (without repeater). Press this key again, the talk around function goes off.

- **Temporary delete**

The "Add" channel contained in the scan sequence, and "Delete" channel is not contained. In the scan mode, this key switches the channel delete temporarily (Press and hold for approximately one second).

When the transceiver is turned off, the transceiver exits the scan or switches the scan function off.

- **None**

Sounds error operation beep, and no action will occur. Use this function when the transceiver is required to be more simple operated.

- **Group**

If Group has been programmed onto a key, press the Group key to select the second group of channels. While active, the LED beside the key lights. At this time, press a key from 1 to 4 to select a channel from 5 to 8. To return to channels 1 through 4, press the Group key again.

**Note:** You cannot use the Group function while operating in Emergency mode.

## 4. Scan Operating

### ■ SCAN start condition

Two or more channels must be added to all channels that can be scanned. The transceiver must be in normal receive mode (PTT off).

When you activate the key programmed to the scan ON/OFF function, the scan starts. The indicator next to the programmed key LED blinks.

### ■ Scan stop condition

The scan stops temporarily if the following conditions are satisfied.

- 1) A carrier is detected, then QT/DQT matches on channels for which receive the QT/DQT is set by the programming software.
- 2) A carrier is detected on the channels for which receiving QT/DQT is not set by the programming software or when the monitor (signalling cancel) function is activated.

### ■ Revert channel

The revert channel is used to transmit during scanning and set by the programming software (KPG-70D).

- 1) Selected channel

The transceiver reverts to the channel before scanning or the channel that you changed during scan.

- 2) Selected with talkback

The transceiver reverts to the selected channel prior to scan initiation.

However, if a call is received on a channel other than the selected channel and PTT is pressed before scanning resume, the transceiver "talks back" on the current receive channel.

### ■ Scan end

When you press the key programmed to the scan function during scan mode, the scan ends.

The indicator next to the programmed key LED turns off.

## OPERATING FEATURES

### ■ Temporary delete

It is possible to delete channel temporary during scan. When scan stops on unnecessary channel for example by interference of the other party, activate the delete function (for example press and hold the key for approximately one second), then that channel is deleted temporarily and scan re-start immediately.

The temporary deleted channels return to pre-set delete/add channels, when the transceiver is turned off or the scan function is switched off.

## 5. Details of Features

### ■ Time-out timer

The time-out timer can be programmed in 30 seconds increments from 30 seconds to five minutes and off. If the transmitter is transmitted continuously for longer than the programmed time, the transmitter is disabled and a warning tone sounds while the PTT button is held down. The warning tone stops when the PTT button is released.

### ■ PTT ID

PTT ID provides a DTMF ANI to be sent with every time PTT (beginning of transmission, end of transmission, or both).

You can program PTT ID "on" or "off" for each channel. The contents of ID are programmed each Radio.

The timing that the transceiver sends ID is programmable.

BOT : DTMF ID (Beginning of TX) is sent on beginning of transmission.

EOT : DTMF ID (End of TX) is sent on end of transmission.

Both : DTMF ID (Beginning of TX) is sent on beginning of transmission and DTMF ID (End of TX) is sent on end of transmission.

### ■ Off hook decode

If the Off hook decode function has been enabled, removing and replacing the microphone on the hook has no effect for decoding QT/DQT and option signalling.

### ■ "TOT" pre-alert

The transceiver has "TOT" pre-alert timer. This parameter selects the time at which the transceiver generates "TOT" pre-alert tone before "TOT" is expired.

"TOT" will be expired when the selected time passes from a TOT pre-alert tone.

### ■ "TOT" re-key time

The transceiver has "TOT" re-key timer. This timer is the time you can not transmit after "TOT" exceeded. After "TOT" re-key time expired you can transmit again.

### ■ "TOT" reset time

The transceiver has "TOT" reset timer. This timer is the minimum wait time allowed during a transmission that will reset the "TOT" count.

"TOT" reset time causes the "TOT" to continue even after PTT is released unless the "TOT" reset timer has expired.

### ■ Clear to transpond

The transceiver waits the transpond of DTMF if channel is busy until channel open. This feature prevents the interference to other party.

## 6. Option Signalling (DTMF)

Built-in DTMF decoder is available for option signalling.

It is possible to use individual call, group call, Stun.

If the option signalling matches, a predetermined action will occur.

If option signalling matches on a channel is set up with option signalling, the channel LED will flash and option signalling will be released. The transpond or alert tone will sound.

While option signalling matches (or if option signalling is deactivated when you are transmitting), you can mute or unmute QT/DQT/Carrier.

### ■ SP Unmute

You can select the type of SP Unmute system for each channel. The selection is as follows.

Carrier, QT/DQT:

Channel with this option will not check ID Code in order to open its speaker.

Carrier+DTMF, QT/DQT+DTMF:

Channel that is set with this option will have to check for ID Code in order to open its speaker.

Default:

Carrier, QT/DQT.

| SP Unmute    | Channel Setting |      | RX Condition  | Speaker Condition              |
|--------------|-----------------|------|---|--------------------------------|
|              | QT/DQT          | DTMF |   |                                |
| Carrier      | None            | None | Carrier   | Sounds                         |
|              |                 | Yes  | Carrier<br>Carrier+DTMF                               | Sounds                         |
| Carrier+DTMF | None            | Yes  | Carrier   | Not Sounds                     |
|              |                 |      | Carrier+DTMF  | Sounds                         |
| QT/DQT       | Yes             | None | Carrier   | Not Sounds                     |
|              |                 |      | Carrier+QT/DQT  | Sounds                         |
|              |                 | Yes  | Carrier   | Not Sounds                     |
|              |                 |      | Carrier+QT/DQT<br>Carrier+QT/DQT+DTMF<br>Carrier+DTMF | Sounds<br>Sounds<br>Not Sounds |
| QT/DQT+DTMF  | Yes             | Yes  | Carrier   | Not Sounds                     |
|              |                 |      | Carrier+QT/DQT  | Not Sounds                     |
|              |                 |      | Carrier+QT/DQT+DTMF                                   | Sounds                         |
|              |                 |      | Carrier+DTMF  | Not Sounds                     |

Note:

When QT/DQT is not used, QT/DQT and QT/DQT+DTMF can not be selected.

When DTMF is not used, Carrier+DTMF and QT/DQT+DTMF can not be selected.

### ■ Auto Reset

If option signalling matches a group set up with option signalling, option signalling is released. After matching option signalling, option signalling will temporarily reset automatically.

# OPERATING FEATURES / REALIGNMENT

## ■ Stun

If the stun code matches, a predetermined action will occur. Whether option signalling is activated or not, when stun matches on any channel, the transceiver will become TX inhibited or TX/RX inhibited. While stun is active, if the stun code + "#" code is received, stun will deactivate.

When stun matches, transpond will function. Alert will not be output.

## 7. Audible User Feedback Tones

The transceiver outputs various combinations of tones to notify the user of the transceiver operating state.

Refer to the help file on the KPG-70D, regarding the functions that are not listed below.

### ■ Stun on tone

When a stun code is received, transpond tone sounds.

### ■ Stun off tone

When a stun release code is received, transpond tone sounds.

### ■ Group call tone

Sounds when a group call with the correct DTMF option signalling is received, repeats 7 times. You can select yes or no in the Alert tone level setting.

### ■ Individual call tone

Sounds when an individual call with the correct DTMF option signalling is received. You can select yes or no in the Alert tone level setting.

### ■ Key input error tone

Sounds when a key is pressed but that key cannot be used. You can select yes or no for the optional feature's warning tone.

### ■ Transpond tone

Sounds when an individual call with the correct DTMF option signalling is received. For group calls, only the group tone will sound, not the transpond tone.

### ■ Pre alert tone

Sounds prior to the TOT TX inhibit activation. If TOT pre alert is set, the tone sounds at the amount of time programmed, before the TOT expires (TOT time – TOT pre alert time = Pre alert tone sounding time). You can select yes or no for the optional feature's warning tone.

### ■ Transmit protection

The power module is protected against heat while transmitting by making the radio cuts down TX power when the temperature of the power module becomes higher than reference. After that, if the temperature continue to rise, transmission is stopped. The power module is also protected against over voltage by having the radio to check that the voltage of power supply connected to the radio is not higher than about 17V when the radio is turned on, otherwise it can not transmit. In both cases when transmission is stopped, a beep will continue to sound until the PTT key is released.

## REALIGNMENT

### 1. Modes

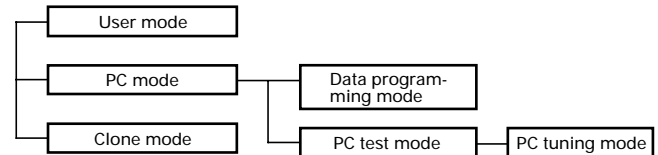

| Mode                  | Function  |
|-----------------------|---|
| User mode             | For normal use.   |
| PC mode               | Used for communication between the radio and PC (IBM compatible).               |
| Data programming mode | Used to read and write frequency data and other features to and from the radio. |
| PC test mode          | Used to check the radio using the PC. This feature is included in the FPU.      |
| PC tuning mode        | Used to tune the radio using the PC.  |
| Clone mode            | Used to transfer programming data from one radio to another.                    |

### 2. How to Enter Each Mode

| Mode       | Operation                  |
|------------|----------------------------|
| User mode  | Power ON                   |
| PC mode    | Received commands from PC  |
| Clone mode | [1]+Power ON (Two seconds) |

### 3. PC Mode

#### 3-1. Preface

The TK-8108 transceiver is programmed using a personal computer, a programming interface (KPG-46) and programming software (KPG-70D).

The programming software can be used with an IBM PC or compatible. Figure 1 shows the setup of an IBM PC for programming.

#### 3-2. Connection Procedure

1. Connect the TK-8108 to the personal computer with the interface cable.
2. When the Power is switched on, user mode can be entered immediately. When the PC sends a command, the radio enters PC mode.  
When data is transmitted from transceiver, the red LED blink.  
When data is received by the transceiver, the green LED blink.  
In the PC mode, 4CH LEDs, [MON] LED and [●] LED are turned on.

#### Notes :

- The data stored in the personal computer must match model type when it is written into the EEPROM.
- Attach the interface cable, then change the TK-8108 to PC mode.



## REALIGNMENT

### 3-3. KPG-46 Description

#### (PC programming interface cable : Option)

The KPG-46 is required to interface the TK-8108 to the computer. It has a circuit in its D-subconnector (25-pin) case that converts the RS-232C logic level to the TTL level.

The KPG-46 connects the modular microphone jack of the TK-8108 to the computers RS-232C serial port.

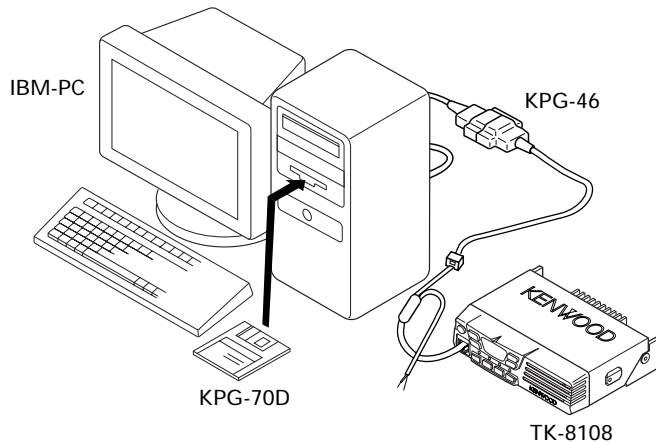

Fig. 1

### 3-4. Programming Software Description

The KPG-70D programming disk is supplied in 3-1/2" disk format. The software on this disk allows a user to program TK-8108 radio via a programming interface cable (KPG-46).

### 3-5. Programming With IBM PC

If data is transferred to the transceiver from an IBM PC with the KPG-70D, the destination data (basic radio information) for each set can be modified.

## 4. Clone Mode

Programming data can be transferred from one radio to another by connecting them via their modular microphone jacks. The operation is as follows (the transmit radio is the master and the receive radio is the slave).

**NOTE:** Clone mode should enabled.

1. Turn the master TK-8108 power ON with the [1] key held down. The TK-8108 [●] LED is turned on.
2. Power on the slave TK-8108.
3. Connect the cloning cable (No. E30-3382-05) to the modular microphone jacks on the master and slave.
4. Press the [●] key on the master TK-8108 transceiver. The data of the master is sent to the slave. While the master is sending data, [TX] LED blinked. While the slave is receiving the data, 4 LEDs, [MON] LED, [●] LED are turned on and [BUSY] LED blinked. When cloning of data is completed, the master [TX] LED turned off, and the slave automatically operates in the User mode. The slave can then be operated by the same program as the master.
5. The other slave can be continuously cloned. Carry out the operation in step 2 to 4.

### Adding the data password.

If the data password is set in the optional feature menu, you must enter the password (Master transceiver) to activate a clone mode.

you can use 1, 2, 3, and 4 to configure the password. The maximum length of the password is 10 digits.

1. [1]+Power ON.
2. [1]~[4] LED, and MON LED are turned ON.
3. Enter the password using [1]~[4] keys.
4. Press [MON] key.
5. If the password matches, the transceiver enters a clone mode. Otherwise, transceiver beeps and returns to the password input mode.

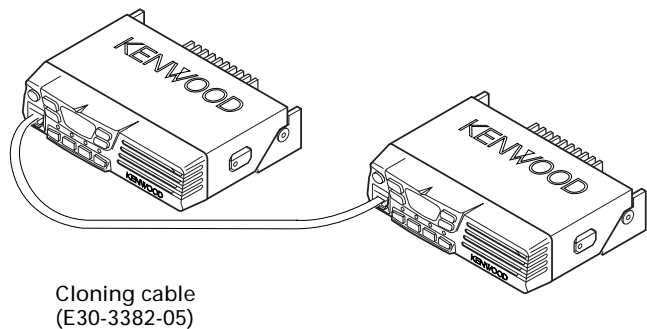

Fig. 2

## DISASSEMBLY FOR REPAIR

1. When you remove the panel, turn the transceiver up side down. Detach the panel by lifting the tabs as shown below.

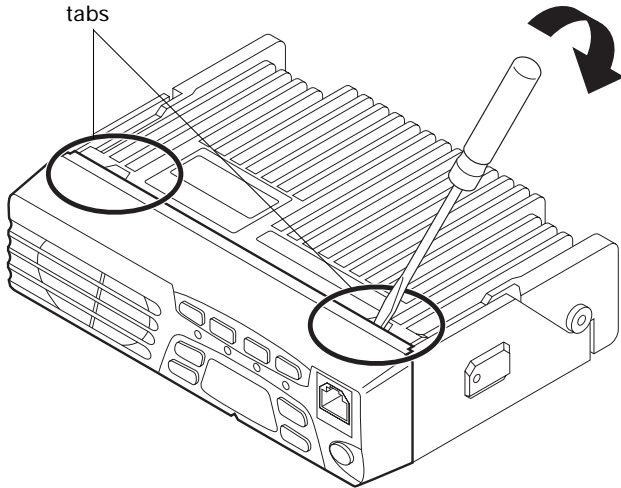

Fig. 1

3. To remove the display unit PCB, detach the PCB by lifting at the indents of the PCB as shown below.

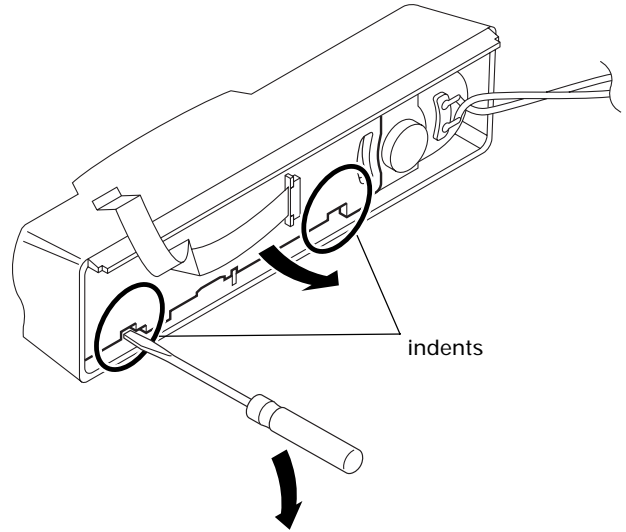

Fig. 3

2. To remove the cabinet, first turn the transceiver up side down. Detach the cabinet by prying the tabs as shown below.

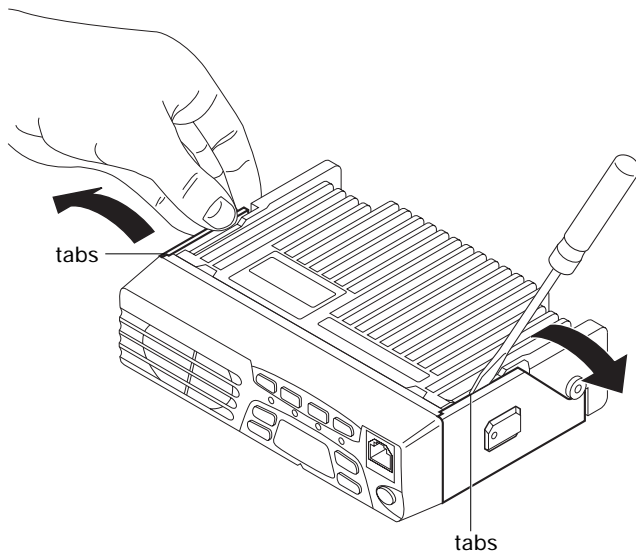

Fig. 2

4. When mounting the front panel, match the 4 tabs of the chassis with the panel, being sure they attach securely.

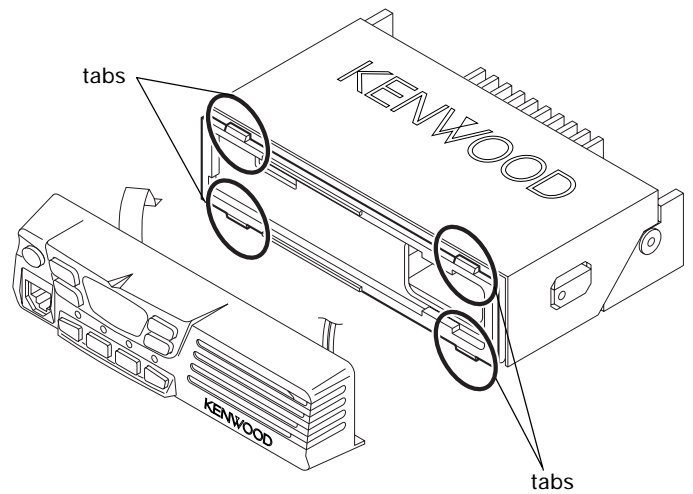

Fig. 4

## CIRCUIT DESCRIPTION

### Frequency Configuration

The receiver utilizes double conversion. The first IF is 49.95MHz and the second IF is 450kHz. The first local oscillator signal is supplied from the PLL circuit.

The PLL circuit in the transmitter generates the necessary frequencies. Figure 1 shows the frequencies.

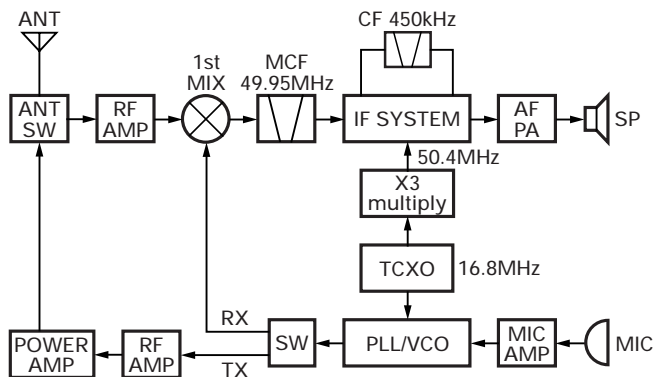

Fig. 1 Frequency configuration

### Receiver System

The receiver is double conversion superheterodyne. The frequency configuration is shown in Figure 1.

#### ■ Front-end RF Amplifier

An incoming signal from the antenna is applied to an RF amplifier (Q26) after passing through a transmit/receive switch circuit (D31 and D32 are off) and a BPF (L36, L38, L48, L49 and varactor diodes: D25, D26, D28). After the signal is amplified (Q26), the signal is filtered by a BPF (L30, L32 and varactor diodes: D21, D22) to eliminate unwanted signals before it is passed to the first mixer.

The voltage of these diodes are controlled by tracking the CPU (IC6) center frequency of the band pass filter. (See Fig. 2)

#### ■ First Mixer

The signal from the RF amplifier is heterodyned with the first local oscillator signal from the PLL frequency synthesizer circuit at the first mixer (Q21) to create a 49.95MHz first intermediate frequency (1st IF) signal. The first IF signal is then fed through two monolithic crystal filters (MCFs : XF1) to further remove spurious signals.

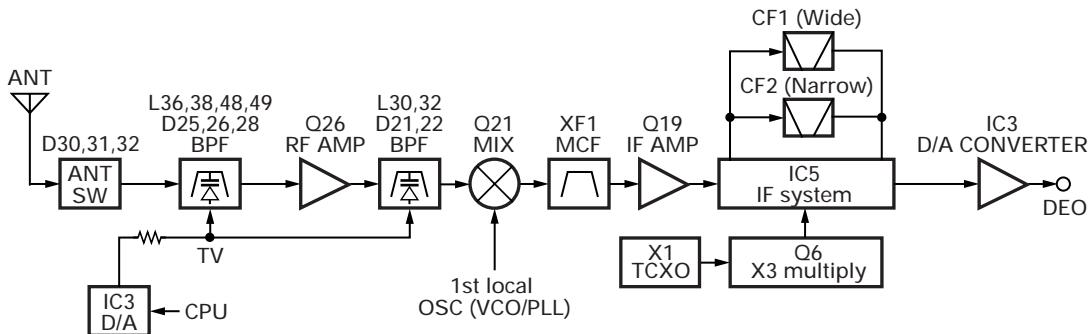

Fig. 2 Receiver system

#### ■ IF Amplifier

The first IF signal is amplified by Q19, and the enters IC5 (FM processing IC). The signal is heterodyned again with a second local oscillator signal within IC5 to create a 450kHz second IF signal. The second IF signal is then fed through a 450kHz ceramic filter (Wide : CF1, Narrow : CF2) to further eliminate unwanted signals before it is amplified and FM detected in IC5.

| Item                     | Rating  |
|--------------------------|---|
| Nominal center frequency | 49.95MHz  |
| Pass bandwidth           | ±5.0kHz or more at 3dB  |
| 35dB stop bandwidth      | ±20.0kHz or less  |
| Ripple                   | 1.0dB or less   |
| Insertion loss           | 5.0dB or less   |
| Guaranteed attenuation   | 80dB or more at fo±1MHz<br>Spurious : 40dB or more within fo±1MHz |
| Terminal impedance       | 350 / 5.5pF   |

Table 1 Crystal filter (L71-0591-05) : XF1

| Item                     | Rating                          |
|--------------------------|---------------------------------|
| Nominal center frequency | 450kHz                          |
| 6dB bandwidth            | ±6.0kHz or more                 |
| 50dB bandwidth           | ±12.5kHz or less                |
| Ripple                   | 2.0dB or less                   |
| Insertion loss           | 6.0dB or less                   |
| Guaranteed attenuation   | 35.0dB or more within fo±100kHz |
| Terminal impedance       | 2.0k                            |

Table 2 Ceramic filter (L72-0993-05) : CF1

| Item                     | Rating                          |
|--------------------------|---------------------------------|
| Nominal center frequency | 450kHz                          |
| 6dB bandwidth            | ±4.5kHz or more                 |
| 50dB bandwidth           | ±10.0kHz or less                |
| Ripple                   | 2.0dB or less                   |
| Insertion loss           | 6.0dB or less                   |
| Guaranteed attenuation   | 60.0dB or more within fo±100kHz |
| Terminal impedance       | 2.0k                            |

Table 3 Ceramic filter (L72-0999-05) : CF2

## CIRCUIT DESCRIPTION

### Wide/Narrow Changeover Circuit

The Wide port (pin 92) and Narrow port (pin 91) of the CPU is used to switch between ceramic filters. When the Wide port is high, the ceramic filter SW diodes (D13, D15) cause CF1 to turn on to receive a Wide signal.

When the Narrow port is high, the ceramic filter SW diodes (D13, D15) cause CF2 to turn on to receive a Narrow signal.

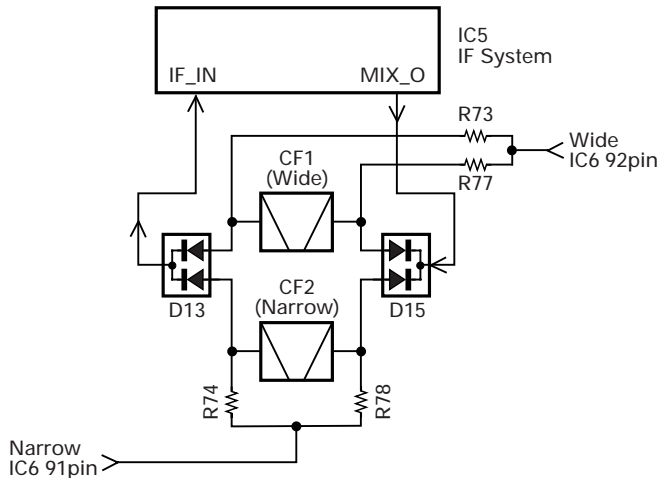

Fig. 3 Wide/Narrow changeover circuit

### AF Signal System

The detection signal from IF IC (IC5) goes to D/A converter (IC3) to adjust the gain and is output to AF filter (IC10) for characterizing the signal. The AF signal output from IC10 and the DTMF signal, BEEP signal are summed and the resulting signal goes to the D/A converter (IC3). The AFO output level is adjusted by the D/A converter. The signal output from the D/A converter is input to the audio power amplifier (IC102). The AF signal from IC102 switches between the internal speaker and speaker jack (J1) output.

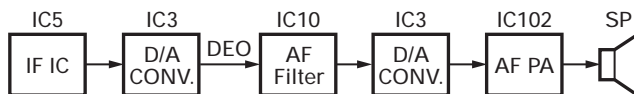

Fig. 4 AF signal system

### Squelch Circuit

The detection output from the FM IF IC (IC5) passes through a noise amplifier (Q18) to detect noise. A voltage is applied to the CPU (IC6). The CPU controls squelch according to the voltage (SQIN) level. The signal from the RSSI pin of IC5 is monitored. The electric field strength of the receive signal can be known before the SQIN voltage is input to the CPU, and the scan stop speed is improved.

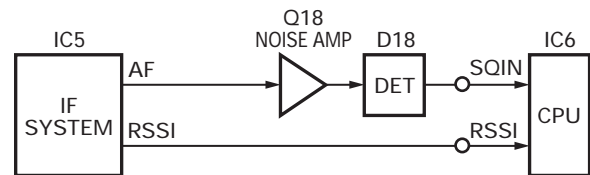

Fig. 5 Squelch circuit

### PLL Frequency Synthesizer

The PLL circuit generates the first local oscillator signal for reception and the RF signal for transmission.

#### PLL

The frequency step of the PLL circuit is 5 or 6.25kHz. A 16.8MHz reference oscillator signal is divided at IC1 by a fixed counter to produce the 5 or 6.25kHz reference frequency. The voltage controlled oscillator (VCO) output signal is buffer amplified by Q15, then divided in IC1 by a dual-module programmable counter. The divided signal is compared in phase with the 5 or 6.25kHz reference signal in the phase comparator in IC1. The output signal from the phase comparator is filtered through a low-pass filter and passed to the VCO to control the oscillator frequency. (See Fig. 6)

#### VCO

The operating frequency is generated by Q11 in transmit mode and Q10 in receive mode. The oscillator frequency is controlled by applying the VCO control voltage, obtained from the phase comparator, to the varactor diodes (D10 and D12 in transmit mode and D9 and D11 in receive mode). The TX/RX pin is set low in receive mode causing Q12 and Q7 to turn Q11 off, and turn Q10 on. The TX/RX pin is set high in transmit mode. The outputs from Q10 and Q11 are amplified by Q15 and sent to the RF amplifiers.

## CIRCUIT DESCRIPTION

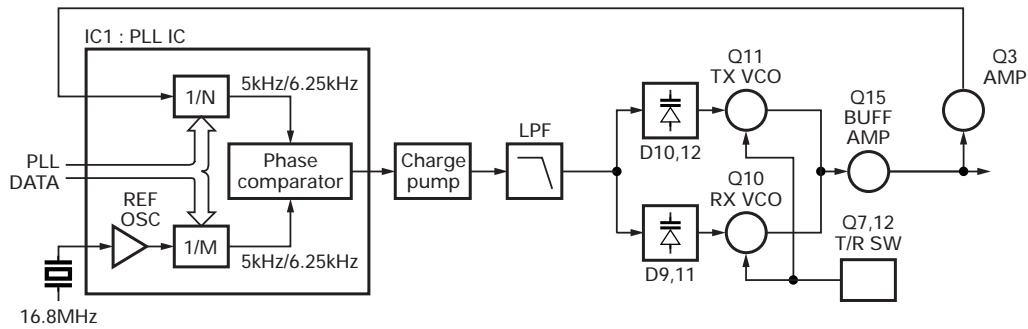

Fig. 6 PLL circuit

### ■ Unlock Circuit

During reception, the 8RC signal goes high, the 8TC signal goes low, and Q29 turns on. Q31 turns on and a voltage is applied to the collector (8R). During transmission, the 8RC signal goes low, the 8TC signal goes high and Q30 turns on. Q33 turns on and a voltage is applied to 8T.

The CPU in the control unit monitors the PLL (IC1) LD signal directly. When the PLL is unlocked during transmission, the PLL LD signal goes low. The CPU detects this signal and makes the 8TC signal low. When the 8TC signal goes low, no voltage is applied to 8T, and no signal is transmitted.

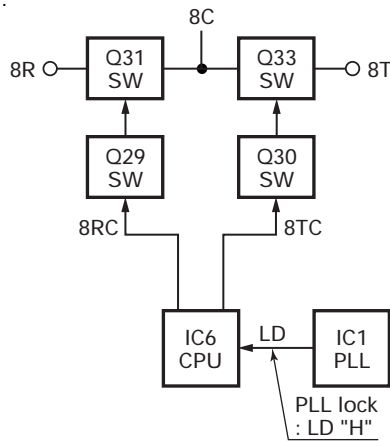

Fig. 7 Unlock circuit

### Transmitter System

#### ■ Outline

The transmitter circuit produces and amplifies the desired frequency directly. It FM-modulates the carrier signal by means of a varicap diode.

#### ■ Power Amplifier Circuit

The transmit output signal from the VCO passes through the transmission/reception selection diode (D19) and amplified to a specified level of the power module (IC101) by the drive block (Q23, Q25 and Q39). The amplified signal goes to a low-pass filter. The low-pass filter removes unwanted high-frequency harmonic components, and the resulting signal is sent to the antenna terminal.

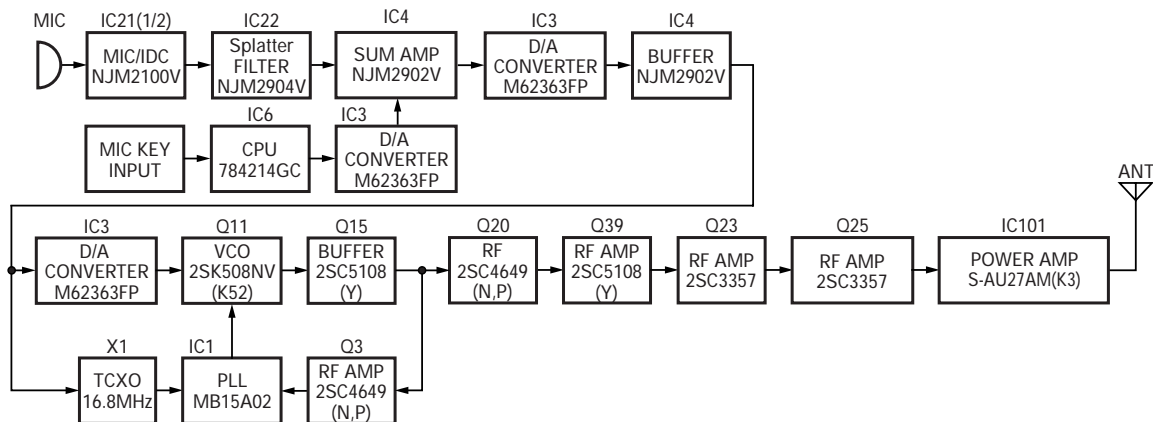

Fig. 8 Transmitter system

## CIRCUIT DESCRIPTION

### ■ APC Circuit

The automatic transmission power control (APC) circuit detects part of a power module output with a diode (D34, D36) and applies a voltage to IC12. IC12 compares the APC control voltage (PC) generated by the D/A converter (IC3) and DC amplifier (IC4) with the detection output voltage to control Q27 and Q101, generates DB voltage from B voltage, and stabilizes transmission output.

The APC circuit is configured to protect over current of the power module due to fluctuations of the load at the antenna end and to stabilize transmission output at voltage and temperature variations.

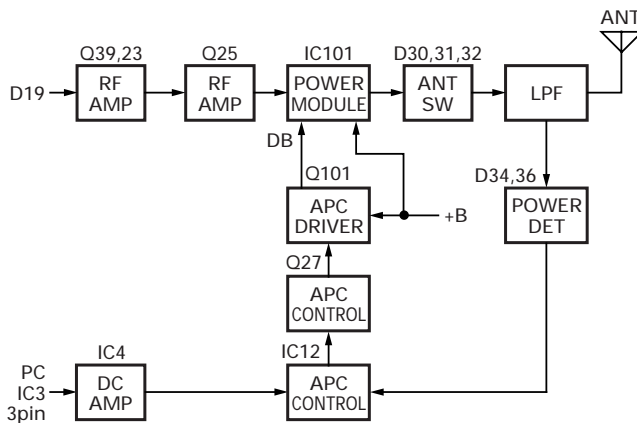

Fig. 9 APC circuit

### Control Circuit

The CPU carries out the following tasks:

- 1) Controls the WIDE, NARROW, TX/RX outputs.
- 2) Adjusts the AF signal level of the AF filter (IC10) and turns the filter select compounder on or off.
- 3) Controls the DTMF decoder (IC9).
- 4) Controls the display unit.
- 5) Controls the PLL (IC1).
- 6) Controls the D/A converter (IC3) and adjusts the volume, modulation and transmission power.

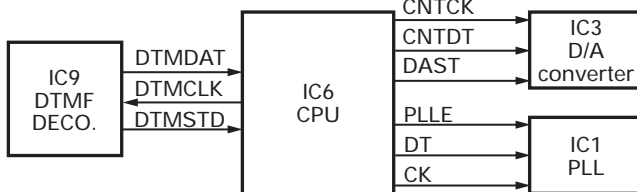

Fig. 10 Control circuit

### ■ Memory Circuit

The transceiver has an 8k-bit EEPROM (IC7). The EEPROM contains adjustment data. The CPU (IC6) controls the EEPROM through three serial data lines.

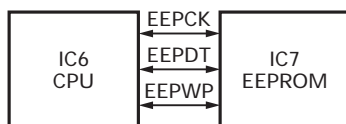

Fig. 11 Memory circuit

### ■ Display Circuit

The CPU (IC6) controls the display LEDs. When the transceiver is busy, the LEDG line goes high, Q4 turns on and the green LED (D11) lights. In transmit mode, the LEDR line goes high, Q8 turns on and the red LED (D12) lights. Backlit LEDs (D1~D4) are provided.

When a function key (MON, PF, C1, C2, C3 or C4) is selected, its respective line goes high (LED MON, LED PF, LED C1, LED C2, LED C3 or LED C4), the switch connected to that line turns on and the amber LED lights.

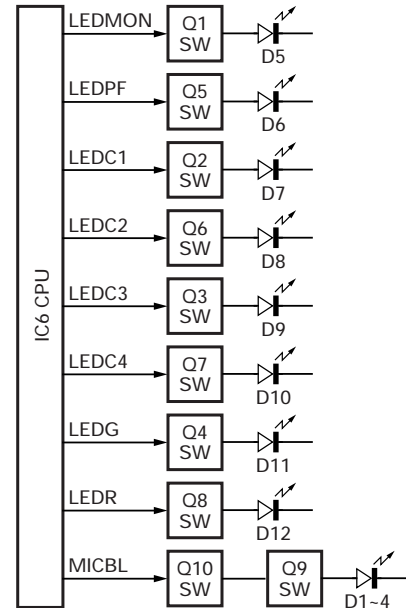

Fig. 12 Display circuit

### ■ Key Matrix Circuit

The TK-8108 front panel has function keys. Each of them is connected to a cross point of a matrix of the KMI1 to KMO2 ports of the microprocessor. The KMO1 to KMO2 ports are always high, while the KMI1 to KMI4 ports are always low.

The microprocessor monitors the status of the KMI1 to KMO2 ports. If the state of one of the ports changes, the microprocessor assumes that the key at the matrix point corresponding to that port has been pressed.

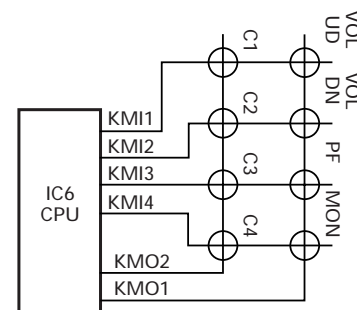

Fig. 13 Key matrix circuit

## CIRCUIT DESCRIPTION

### ■ Encode

The QT and DQT signals are output from QT/DQT of the CPU (IC6) and summed with the external pin DI line by the summing amplifier (IC4) and the resulting signal goes to the D/A converter (IC3). The DTMF and signal is output from DTMF of the CPU and goes to the D/A converter (IC3). The signal is summed with a MIC signal by the summing amplifier (IC4), and the resulting signal goes to the D/A converter (IC3).

The D/A converter (IC3) adjusts the MO level and the balance between the MO and QT/DQT levels. Part of a QT/DQT signal is summed with MO and the resulting signal goes to the VCOMOD pin of the VCO. This signal is applied to a varicap diode in the VCO for direct FM modulation.

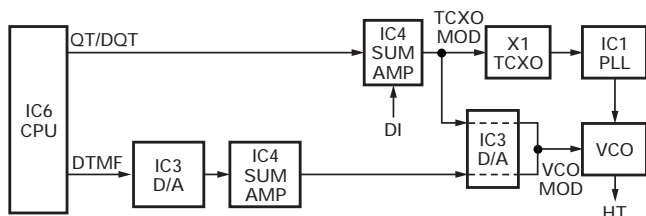

Fig. 14 Encode

### ■ Decode

#### • QT/DQT/DTMF

The signal (DEO) passes through two low-pass filters of IC11, goes to QTIN of the CPU (IC6) to decode QT, DQT. The DTMF signal is decoded by a dedicated IC (IC9) and the resulting signal is sent to the CPU (IC6) as serial data.

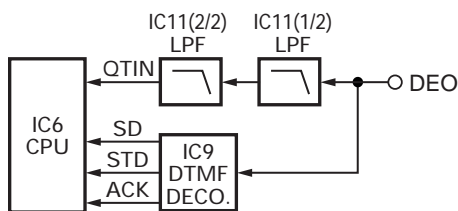

Fig. 15 Decode

### ■ D/A Converter

The D/A converter (IC3) is used to adjust MO modulation, AF volume, TV voltage, FC reference voltage, and PC POWER CONTROL voltage level.

Adjustment values are sent from the CPU as serial data. The D/A converter has a resolution of 256 and the following relationship is valid:

$$D/A \text{ output} = (V_{in} - V_{DAref}) / 256 \times n + V_{DAref}$$

$V_{in}$ : Analog input

$V_{DAref}$ : D/A reference voltage

$n$ : Serial data value from the microprocessor (CPU)

### Power Supply Circuit

When the POWER switch on the display unit is pressed, the power port on the display unit which is connected to CPU port 18 (POWER), goes low, then CPU port 93 (SBC) goes high, Q34 turns on, SB SW (Q42) turns on and power (SB) is supplied to the radio.

This circuit has an overvoltage protection circuit. If a DC voltage of 18 V or higher is applied to the power cable, D39 turns on and a voltage is applied to the base of Q38. This voltage turns Q38 on and turns Q34 and SB off.

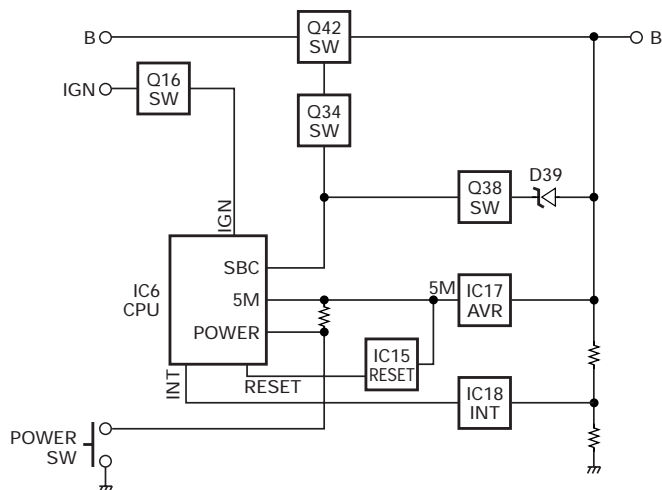

Fig. 16 Power supply circuit

## SEMICONDUCTOR DATA

Microprocessor : 784214AGCXXX (TX-RX Unit IC6)

## ■ Terminal function

| Pin No. | Name     | I/O | Function              | Pin No. | Name   | I/O | Function             |
|---------|----------|-----|-----------------------|---------|--------|-----|----------------------|
| 1       | NC       | I   |                       | 48      | FNC8   | I/O | Function Port8       |
| 2       | DTMOSC   | O   | DTMF IC Clock Control | 49      | NC     | I   |                      |
| 3       | PLLE     | O   | PLL IC Chip Select    | 50      | MUTE1  | O   | AF Mute              |
| 4       | EVLLD    | O   | E-Volume LD           | 51      | MUTE2  | O   | Speaker Mute         |
| 5       | DTMCK    | O   | DTMF Dec IC Clock     | 52      | MUTE3  | O   | AF AMP SW            |
| 6       | DTMDT    | I/O | DTMF Dec IC Data      | 53      | DT     | O   | Common Data          |
| 7       | UL       | O   | Unlock Detect         | 54      | CK     | O   | Common Clock         |
| 8       | BSHIFT   | O   | Clock Shift           | 55      | NC     | I   |                      |
| 9       | VDD      | -   |                       | 56      | EEPCK  | O   | EEPROM Clock         |
| 10      | X2       | -   | X'TAL(7.3728MHz)      | 57      | EEPDT  | I/O | EEPROM Data          |
| 11      | X1       | -   | X'TAL(7.3728MHz)      | 58      | EEPWT  | O   | EED Write Protect    |
| 12      | VSS      | -   | GND                   | 59      | DST1   | I   | Destination 1        |
| 13      | NC       | -   | OPEN                  | 60      | DST2   | I   | Destination 2        |
| 14      | NC       | -   | GND                   | 61      | DST3   | I   | Destination 3 (Open) |
| 15      | RESET    | -   | CPU RESET             | 62      | NC     | I   |                      |
| 16      | INT      | I   | uCOM Stop             | 63      | 24VDET | I   | 24V Detect           |
| 17      | DMTSDT   | I   | DTMF Dec IC STD       | 64      | NC     | I   |                      |
| 18      | POWER    | I   | Power Key Input       | 65      | LEDC1  | O   | LED for CH1 Key      |
| 19      | IGN      | I   | Ignition              | 66      | LEDC2  | O   | LED for CH2 Key      |
| 20      | TX/RX    | O   | TX/RX                 | 67      | LEDR   | O   | TX LED               |
| 21      | LEDMON   | O   | LED for MON Key       | 68      | LEDG   | O   | Busy LED             |
| 22      | LEDPF    | O   | LED for PF Key        | 69      | MICBL  | O   | Mic Back Light       |
| 23      | AVDD     | -   | +5V                   | 70      | LEDC3  | O   | LED for CH3 Key      |
| 24      | AVREF    | -   | +5V                   | 71      | LEDC4  | O   | LED for CH4 Key      |
| 25      | QTIN     | I   | QT/DQT Input          | 72      | VSS    | -   | GND                  |
| 26      | SQIN     | I   | Squelch Input         | 73      | MICMT  | O   | Mic1 Mute            |
| 27      | RSSI     | I   | RSSI Input            | 74      | MICEM  | O   | Mic2 Mute            |
| 28      | PWRPRCT  | I   | Power Protect         | 75      | NC     | I   |                      |
| 29      | BATT     | I   | Battery Voltage       | 76      | 8RC    | O   | 8R Control           |
| 30      | TEMP1    | I   | Temperature1          | 77      | 8TC    | O   | 8T Control           |
| 31      | TEMP2    | I   | Temperature2          | 78      | CM     | I/O | Mic Key Check        |
| 32      | TEMP3    | I   | Temperature3          | 79      | NC     | I   |                      |
| 33      | AVSS     | -   | GND                   | 80      | NC     | I   |                      |
| 34      | DTM/BEEP | O   | DTMF/Beep Output      | 81      | VDD5M  | -   | +5V                  |
| 35      | QT/DQT   | O   | QT/DQT Output         | 82~85   | NC     | I   |                      |
| 36      | AVREF    | -   | +5V                   | 86      | KMI1   | I   | Key Matrix Input1    |
| 37      | FNC1     | I/O | Function Port1        | 87      | KMI2   | I   | Key Matrix Input2    |
| 38      | FNC2     | I/O | Function Port2        | 88      | KMI3   | I   | Key Matrix Input3    |
| 39      | HOOK     | I   | Hook                  | 89      | KMI4   | I   | Key Matrix Input4    |
| 40      | RXD      | I   | From FPU              | 90      | NC     | I   |                      |
| 41      | TXD      | O   | To FPU                | 91      | NARROW | O   | Wide / Narrow2       |
| 42      | PTT      | I   | PTT Key               | 92      | WIDE   | O   | Wide / Narrow        |
| 43      | FNC3     | I/O | Function Port3        | 93      | SBC    | O   | Battery Switch       |
| 44      | FNC4     | I/O | Function Port4        | 94      | FLASH  | -   | Flash Write Port     |
| 45      | FNC5     | I/O | Function Port5        | 95~98   | NC     | I   |                      |
| 46      | FNC6     | I/O | Function Port6        | 99      | KMO1   | O   | Key Matrix Output1   |
| 47      | FNC7     | I/O | Function Port7        | 100     | KMO2   | O   | Key Matrix Output2   |



## COMPONENTS DESCRIPTION

### Display Unit (X54-3340-20)

| SYMBOL | PARTS NAME | DISCRIPTION               |
|--------|------------|---------------------------|
| D1~4   | LED        | KEY BACKLIT               |
| D5     | LED        | MONITOR KEY LIGHT         |
| D6     | LED        | PROGRAMMABLE KEY LIGHT    |
| D7~10  | LED        | CHANNEL KEY LIGHT         |
| D11    | LED        | BUSY                      |
| D12    | LED        | TRANSMIT                  |
| Q1     | TRANSISTOR | MONITOR KEY LIGHT SW      |
| Q2,3   | TRANSISTOR | CHANNEL KEY LIGHT SW      |
| Q4     | TRANSISTOR | BUSY LIGHT SW             |
| Q5     | TRANSISTOR | PROGRAMMABLE KEY LIGHT SW |
| Q6,7   | TRANSISTOR | CHANNEL KEY LIGHT SW      |
| Q8     | TRANSISTOR | TRANSMIT LIGHT SW         |
| Q9,10  | TRANSISTOR | KEY BACKLIT SW            |

### TX-RX Unit (X57-6303-01)

| Ref. No. | Use/Function | Operation/Condition      |
|----------|--------------|--------------------------|
| D1       | DIODE        | SURGE ABSORPTION /PTT    |
| D2       | DIODE        | SURGE ABSORPTION /HOOK   |
| D3       | DIODE        | SURGE ABSORPTION /MICBL  |
| D4       | DIODE        | SURGE ABSORPTION /CM     |
| D6       | DIODE        | DC SWITCH                |
| D7       | DIODE        | VOTAGE DROPPED           |
| D9       | VARICAP      | RX VCO                   |
| D10      | VARICAP      | TX VCO                   |
| D11      | VARICAP      | RX VCO                   |
| D12      | VARICAP      | TX VCO                   |
| D13      | DIODE        | IF SWITCH (WIDE/NARROW)  |
| D14      | VARICAP      | MODULATION               |
| D15      | DIODE        | IF SWITCH (WIDE/NARROW)  |
| D16      | DIODE        | LIPPLE FILTER            |
| D18      | DIODE        | DETECTION                |
| D19      | DIODE        | RF SWITCH(TX/RX)         |
| D21      | VARICAP      | RF BPF TUNING            |
| D22      | VARICAP      | RF BPF TUNING            |
| D23      | DIODE        | TEMPERATURE COMPENSATION |
| D24      | DIODE        | LIMITTER                 |
| D25      | VARICAP      | RF BPF TUNING            |
| D26      | VARICAP      | RF BPF TUNING            |
| D27      | DIODE        | TEMPERATURE COMPENSATION |
| D28      | VARICAP      | RF BPF TUNING            |
| D30      | DIODE        | ANT SW                   |
| D31      | DIODE        | ANT SW                   |

| Ref. No. | Use/Function | Operation/Condition                          |
|----------|--------------|--|
| D32      | DIODE        | ANT SW                                       |
| D34      | DIODE        | APC VOLTAGE DETECT                           |
| D36      | DIODE        | APC VOLTAGE DETECT                           |
| D38      | DIODE        | REVERSE CONNECT PROTECTION                   |
| D39      | DIODE        | OVER VOLTAGE DETECTION                       |
| D41      | POLY SW      | CURRENT PROTECTION                           |
| D43      | DIODE        | OR GATE /Mic Mute, AGC                       |
| D44      | DIODE        | AGC  |
| Q2       | FET          | MIC MUTE<br>/Active while MICEM is H         |
| Q3       | TRANSISTOR   | RF AMP /PLL Fin                              |
| Q4       | TRANSISTOR   | CHARGE PUMP                                  |
| Q5       | TRANSISTOR   | CHARGE PUMP                                  |
| Q6       | TRANSISTOR   | BUFFER AMP<br>/16.8MHz 3rd over tone         |
| Q7       | FET          | T/R SW                                       |
| Q10      | FET          | RX VCO                                       |
| Q11      | FET          | TX VCO                                       |
| Q12      | TRANSISTOR   | T/R SW                                       |
| Q13      | FET          | BEAT SHIFT<br>/Active while Beat shift is on |
| Q14      | TRANSISTOR   | LIPPLE FILTER                                |
| Q15      | TRANSISTOR   | BUFFER AMP /Output of VCO                    |
| Q16      | TRANSISTOR   | IGNITION /Ignition Sens.                     |
| Q18      | TRANSISTOR   | NOISE AMP                                    |
| Q19      | TRANSISTOR   | IF AMP                                       |
| Q20      | TRANSISTOR   | RF AMP /Output of VCO                        |
| Q21      | FET          | MIXER  |
| Q22      | FET          | AF MUTE<br>/Active while Mute1 is H          |
| Q23      | TRANSISTOR   | RF AMP /Drive stage                          |
| Q24      | TRANSISTOR   | BUFFER AMP /RX Audio                         |
| Q25      | TRANSISTOR   | RF AMP /Drive stage                          |
| Q26      | FET          | RF AMP /LNA                                  |
| Q27      | TRANSISTOR   | APC CONTROL                                  |
| Q29      | TRANSISTOR   | DC SWITCH(8R)<br>/Active while RX            |
| Q30      | TRANSISTOR   | DC SWITCH(8T)<br>/Active while TX            |
| Q31      | TRANSISTOR   | DC SWITCH(8R)<br>/Active while RX            |
| Q32      | TRANSISTOR   | AF MUTE<br>/Active while Mute2 is H          |
| Q33      | TRANSISTOR   | DC SWITCH(8T)<br>/Active while TX            |

## COMPONENTS DESCRIPTION

| Ref. No. | Use/Function | Operation/Condition   |
|----------|--------------|---|
| Q34      | TRANSISTOR   | DC SWITCH(SB)<br>/Active when power on                              |
| Q35      | TRANSISTOR   | AF MUTE<br>/Active while Mute3 is H                                 |
| Q37      | FET          | BEAT SHIFT<br>/Active while Beat shift is on                        |
| Q38      | TRANSISTOR   | OVER VOLTAGE DETECTION<br>/Active while PS voltage is more than 18V |
| Q39      | TRANSISTOR   | RF AMP /Drive stage   |
| Q41      | TRANSISTOR   | MIC MUTE<br>/Emergency Mic mute                                     |
| Q42      | TRANSISTOR   | DC SWITCH(SB)<br>/Active when power on                              |
| Q43      | FETs         | AF MUTE<br>Active while Mute1 is H                                  |
| Q101     | TRANSISTOR   | APC DRIVER  |
| IC1      | IC           | PLL SYNTHESIZER   |
| IC3      | IC           | D/A CONVERTER   |
| IC4      | IC           | BUFFER AMP / SUM AMP /<br>DC AMP / 1/2V <sub>cc</sub>               |
| IC5      | IC           | IF DEMODULATION   |
| IC6      | IC           | CPU   |
| IC7      | IC           | EEPROM  |
| IC9      | IC           | DTMF DECODE   |
| IC10     | IC           | AUDIO FILTER  |
| IC11     | IC           | ACTIVE FILTER (QT/DQT)  |
| IC12     | IC           | APC CONTROL   |
| IC14     | IC           | VOLTAGE REGULATOR (5C)  |
| IC15     | IC           | VOLTAGE DETECTOR RESET  |
| IC17     | IC           | VOLTAGE REGULATOR (5M)  |
| IC18     | IC           | VOLTAGE DETECTOR INT  |
| IC19     | IC           | DIVIDER (7.159MHz)  |
| IC20     | IC           | VOLTAGE REGULATOR (8C)  |
| IC21     | IC           | MIC AMP / IDC   |
| IC22     | IC           | SPLATTER FILTER   |
| IC101    | IC           | POWER MODULE  |
| IC102    | IC           | AF POWER AMP  |

## PARTS LIST

\* New Parts.  $\Delta$  indicates safety critical components.  
 Parts without **Parts No.** are not supplied.  
 Les articles non mentionnes dans le **Parts No.** ne sont pas fournis.  
 Teile ohne **Parts No.** werden nicht geliefert.

### TK-8108 (Y51-4850-21)

| Ref. No.                          | Address | New parts | Parts No.     | Description                   | Destination |
|-----------------------------------|---------|-----------|---------------|-------------------------------|-------------|
| <b>TK-8108</b>                    |         |           |               |                               |             |
| 1                                 | 1B      | *         | A01-2178-02   | CABINET                       |             |
| 2                                 | 3B      | *         | A10-4047-01   | CHASSIS                       |             |
| 3                                 | 3A      | *         | A62-0942-03   | PANEL ASSY                    |             |
| 4                                 | 3A      | *         | B10-2668-03   | FRONT GLASS                   |             |
| 5                                 | 2C      | *         | B62-1664-10   | INSTRUCTION MANUAL            |             |
| 6                                 | 3B      | *         | B72-2104-04   | MODEL NAME PLATE              |             |
| 7                                 | 3B      |           | E04-0167-05   | RF COAXIAL PECEPTACLE(M)      |             |
| 8                                 | 1C      |           | E30-3339-05   | DC CORD ACCESSORY             |             |
| 9                                 | 2B      | *         | E30-3448-05   | DC CORD(RADIO)                |             |
| 10                                | 2A      | *         | E37-0961-05   | FLAT CABLE                    |             |
| 11                                | 3A      | *         | E37-0962-05   | SPEAKER CABLE                 |             |
| 12                                | 2B      | *         | F10-2405-12   | SHIELDING COVER(UPPER)        |             |
| 13                                | 2B      | *         | F10-2414-03   | SHIELDING PLATE(POWER MODULE) |             |
| 14                                | 1C      |           | F51-0016-05   | FUSE(10A) ACCESSORY           |             |
| 15                                | 3B      | *         | G02-0887-03   | EARTH SPRING(TX/RX)           |             |
| 16                                | 3B      |           | G13-1468-04   | CUSHION(DC CORD)              |             |
| 17                                | 3A      | *         | G13-1836-04   | CUSHION(SPEAKER)              |             |
| 18                                | 1B      |           | G53-1524-03   | PACKING                       |             |
| 19                                | 3B      | *         | G53-1525-03   | PACKING(PANEL)                |             |
| 20                                | 2B      | *         | G53-1542-03   | PACKING(PHONE JACK)           |             |
| 21                                | 1C      |           | H02-0617-02   | INNER PACKING CASE            |             |
| 22                                | 2D      | *         | H10-6636-03   | POLYSTYRENE FOAMED FIXTURE    |             |
| 23                                | 2C      | *         | H10-6639-03   | POLYSTYRENE FOAMED FIXTURE    |             |
| 24                                | 1C      |           | H25-0103-04   | PROTECTION BAG                |             |
| 25                                | 2C      | *         | H25-2320-04   | PROTECTION BAG                |             |
| 26                                | 3C      | *         | H52-1669-12   | ITEM CARTON CASE              |             |
| 27                                | 1D      |           | J29-0662-03   | BRACKET ACCESSORY             |             |
| 28                                | 2A      | *         | K29-9065-01   | KEY TOP                       |             |
| A                                 | 2B      |           | N67-3008-46   | PAN HEAD SEMS SCREW W         |             |
| B                                 | 2B,3B   |           | N87-2606-46   | BRAZIER HEAD TAPTITE SCREW    |             |
| C                                 | 1B,2B   |           | N87-2614-46   | BRAZIER HEAD TAPTITE SCREW    |             |
| D                                 | 1C      |           | N99-0395-05   | SCREW SET ACCESSORY           |             |
| SP                                | 3A      | *         | T07-0727-05   | SPEAKER                       |             |
| <b>DISPLAY UNIT (X54-3340-20)</b> |         |           |               |                               |             |
| D1-4                              |         | *         | B30-2238-05   | LED(Y)                        |             |
| D5-10                             |         | *         | B30-2239-05   | LED(SY)                       |             |
| D11                               |         | *         | B30-2237-05   | LED(YG)                       |             |
| D12                               |         | *         | B30-2240-05   | LED(SR)                       |             |
| C4                                |         |           | CK73GB1H103K  | CHIP C 0.010UF K              |             |
| C8-17                             |         |           | CK73GB1H103K  | CHIP C 0.010UF K              |             |
| C18                               |         |           | CC73GCH1H101J | CHIP C 100PF J                |             |
| C19                               |         |           | CK73GB1H102K  | CHIP C 1000PF K               |             |
| CN1                               |         | *         | E40-6170-05   | FLAT CABLE CONNECTOR          |             |
| J1                                |         |           | E08-0877-05   | MODULAR JACK                  |             |
| CP3,4                             |         | *         | RK75GB1J392J  | CHIP-COM 3.9K J 1/16W         |             |
| R1-6                              |         |           | RK73GB1J102J  | CHIP R 1.0K J 1/16W           |             |
| R7-15                             |         |           | RK73FB2A272J  | CHIP R 2.7K J 1/10W           |             |
| Q1-8                              |         |           | KRC102S       | DIGITAL TRANSISTOR            |             |

### TX-RX UNIT (X57-6303-01)

| Ref. No.                        | Address | New parts | Parts No.     | Description           | Destination |
|---------------------------------|---------|-----------|---------------|-----------------------|-------------|
| Q9                              |         |           | KRA225S       | DIGITAL TRANSISTOR    |             |
| Q10                             |         |           | KRC102S       | DIGITAL TRANSISTOR    |             |
| <b>TX-RX UNIT (X57-6303-01)</b> |         |           |               |                       |             |
| C12                             |         |           | CK73GB1H102K  | CHIP C 1000PF K       |             |
| C14                             |         |           | C92-0560-05   | CHIP-TAN 10UF 6.3WV   |             |
| C22                             |         |           | CK73GB1H102K  | CHIP C 1000PF K       |             |
| C24                             |         |           | CK73GB1H103K  | CHIP C 0.010UF K      |             |
| C25                             |         |           | CC73GCH1H220J | CHIP C 22PF J         |             |
| C26                             |         |           | CK73GB1C104K  | CHIP C 0.10UF K       |             |
| C27                             |         |           | C92-0560-05   | CHIP-TAN 10UF 6.3WV   |             |
| C28                             |         |           | CK73GB1H471K  | CHIP C 470PF K        |             |
| C29,30                          |         |           | CK73GB1C104K  | CHIP C 0.10UF K       |             |
| C31,32                          |         |           | C92-0507-05   | CHIP-TAN 4.7UF 6.3WV  |             |
| C34                             |         |           | CK73GB1C104K  | CHIP C 0.10UF K       |             |
| C35                             |         |           | C92-0560-05   | CHIP-TAN 10UF 6.3WV   |             |
| C36                             |         |           | CK73GB1H103K  | CHIP C 0.010UF K      |             |
| C37                             |         |           | CK73GB1C104K  | CHIP C 0.10UF K       |             |
| C40                             |         |           | C92-0514-05   | CHIP-TAN 2.2UF 10WV   |             |
| C42                             |         |           | CK73GB1H102K  | CHIP C 1000PF K       |             |
| C44                             |         |           | CK73GB1C273K  | CHIP C 0.027UF K      |             |
| C45                             |         |           | CK73GB1H102K  | CHIP C 1000PF K       |             |
| C48,49                          |         |           | CK73GB1H471K  | CHIP C 470PF K        |             |
| C50                             |         |           | CK73GB1C223K  | CHIP C 0.022UF K      |             |
| C51                             |         |           | CK73GB1C104K  | CHIP C 0.10UF K       |             |
| C52                             |         |           | C92-0507-05   | CHIP-TAN 4.7UF 6.3WV  |             |
| C53                             |         |           | CK73GB1C104K  | CHIP C 0.10UF K       |             |
| C54                             |         |           | C92-0560-05   | CHIP-TAN 10UF 6.3WV   |             |
| C55                             |         |           | CK73GB1H471K  | CHIP C 470PF K        |             |
| C56                             |         |           | C92-0555-05   | CHIP-TAN 0.047UF 35WV |             |
| C58                             |         |           | CK73GB1H122K  | CHIP C 1200PF K       |             |
| C59                             |         |           | CK73GB1E103K  | CHIP C 0.010UF K      |             |
| C60                             |         |           | C92-0543-05   | CHIP-TAN 3.3UF 10WV   |             |
| C61                             |         |           | CK73GB1H821K  | CHIP C 820PF K        |             |
| C62                             |         |           | CK73GB1H332K  | CHIP C 3300PF K       |             |
| C63                             |         |           | CK73GB1H472K  | CHIP C 4700PF K       |             |
| C64                             |         |           | C92-0560-05   | CHIP-TAN 10UF 6.3WV   |             |
| C65                             |         |           | C92-0001-05   | CHIP-C 0.1UF 35WV     |             |
| C66                             |         |           | CC73GCH1H151J | CHIP C 150PF J        |             |
| C69                             |         |           | CK73GB1H471K  | CHIP C 470PF K        |             |
| C71                             |         |           | CK73GB1C104K  | CHIP C 0.10UF K       |             |
| C73,74                          |         |           | CC73GCH1H080B | CHIP C 8.0PF B        |             |
| C75                             |         |           | CC73GCH1H060B | CHIP C 6.0PF B        |             |
| C77                             |         |           | CC73GCH1H0R5B | CHIP C 0.5PF B        |             |
| C78                             |         |           | CC73GCH1H060B | CHIP C 6.0PF B        |             |
| C79                             |         |           | CK73GB1H471K  | CHIP C 470PF K        |             |
| C80                             |         |           | CK73GB1H103K  | CHIP C 0.010UF K      |             |
| C81                             |         |           | CC73GCH1H271J | CHIP C 270PF J        |             |
| C82                             |         |           | CK73GB1H471K  | CHIP C 470PF K        |             |
| C84                             |         |           | CK73GB1C104K  | CHIP C 0.10UF K       |             |
| C85                             |         |           | CC73GCH1H010B | CHIP C 1.0PF B        |             |
| C86                             |         |           | CC73GCH1H1R5B | CHIP C 1.5PF B        |             |
| C87                             |         |           | CC73GCH1H560J | CHIP C 56PF J         |             |
| C88                             |         |           | CK73GB1C104K  | CHIP C 0.10UF K       |             |
| C89                             |         |           | CC73GCH1H270J | CHIP C 27PF J         |             |
| C90                             |         |           | CK73GB1H471K  | CHIP C 470PF K        |             |

## PARTS LIST

TX-RX UNIT (X57-6303-01)

| Ref. No. | Address | New parts | Parts No.     | Description         | Destination | Ref. No. | Address | New parts | Parts No.     | Description          | Destination |
|----------|---------|-----------|---------------|---------------------|-------------|----------|---------|-----------|---------------|----------------------|-------------|
| C94      |         |           | CC73GCH1H101J | CHIP C 100PF J      |             | C185     |         |           | CK73GB1H103J  | CHIP C 0.010UF J     |             |
| C95      |         |           | CC73GCH1H050B | CHIP C 5.0PF B      |             | C186     |         |           | CC73GCH1H0R5B | CHIP C 0.5PF B       |             |
| C97      |         |           | CC73GCH1H040B | CHIP C 4.0PF B      |             | C187,188 |         |           | CK73GB1H471K  | CHIP C 470PF K       |             |
| C99      |         |           | CC73GCH1H050B | CHIP C 5.0PF B      |             | C191     |         |           | CK73GB1C473K  | CHIP C 0.047UF K     |             |
| C100     |         |           | CC73GCH1H040B | CHIP C 4.0PF B      |             | C192,193 |         |           | CK73GB1H103J  | CHIP C 0.010UF J     |             |
| C101     |         |           | CK73GB1H471K  | CHIP C 470PF K      |             | C194     |         |           | CK73GB1H471K  | CHIP C 470PF K       |             |
| C102     |         |           | CK73GB1C104K  | CHIP C 0.10UF K     |             | C196     |         |           | CK73GB1C333K  | CHIP C 0.033UF K     |             |
| C103     |         |           | C92-0568-05   | CHIP-TAN 22UF 10WV  |             | C197     |         |           | CK73GB1H471K  | CHIP C 470PF K       |             |
| C104,105 |         |           | CC73GCH1H0R5B | CHIP C 0.5PF B      |             | C198     |         |           | CK73GB1C333K  | CHIP C 0.033UF K     |             |
| C106     |         |           | CC73GCH1H180J | CHIP C 18PF J       |             | C199     |         |           | CC73GCH1H080B | CHIP C 8.0PF B       |             |
| C107     |         |           | CC73GCH1H060B | CHIP C 6.0PF B      |             | C200     |         |           | CC73GCH1H090B | CHIP C 9.0PF B       |             |
| C108,109 |         |           | CK73GB1H471K  | CHIP C 470PF K      |             | C201     |         |           | CK73GB1H471K  | CHIP C 470PF K       |             |
| C110     |         |           | CC73GCH1H060B | CHIP C 6.0PF B      |             | C202     |         |           | CC73GCH1H150J | CHIP C 15PF J        |             |
| C111,112 |         |           | CC73GCH1H221J | CHIP C 220PF J      |             | C204     |         |           | CK73GB1H471K  | CHIP C 470PF K       |             |
| C113     |         |           | CK73GB1H471K  | CHIP C 470PF K      |             | C207     |         |           | CC73GCH1H221J | CHIP C 220PF J       |             |
| C114     |         |           | CK73GB1C104K  | CHIP C 0.10UF K     |             | C208     |         |           | CK73GB1H103K  | CHIP C 0.010UF K     |             |
| C115     |         |           | CC73GCH1H060B | CHIP C 6.0PF B      |             | C209,210 |         |           | CK73GB1H471K  | CHIP C 470PF K       |             |
| C116,117 |         |           | CK73GB1C104K  | CHIP C 0.10UF K     |             | C211     |         |           | CK73GB1E183K  | CHIP C 0.018UF K     |             |
| C118     |         |           | CC73GCH1H020B | CHIP C 2.0PF B      |             | C212     |         |           | CK73GB1H822K  | CHIP C 8200PF K      |             |
| C119     |         |           | CK73GB1H103K  | CHIP C 0.010UF K    |             | C213     |         |           | CK73GB1H471K  | CHIP C 470PF K       |             |
| C120     |         |           | CK73GB1H472K  | CHIP C 4700PF K     |             | C214     |         |           | CK73GB1C683K  | CHIP C 0.068UF K     |             |
| C122     |         |           | CC73GCH1H040B | CHIP C 4.0PF B      |             | C216     |         |           | CC73GCH1H070B | CHIP C 7.0PF B       |             |
| C123     |         |           | C92-0662-05   | CHIP-TAN 15UF 6.3WV |             | C217     |         |           | CK73FB1A105K  | CHIP C 1.0UF K       |             |
| C125,126 |         |           | CK73GB1H471K  | CHIP C 470PF K      |             | C218     |         |           | CK73GB1C104K  | CHIP C 0.10UF K      |             |
| C127     |         |           | CK73GB1H103K  | CHIP C 0.010UF K    |             | C220     |         |           | CK73GB1C473K  | CHIP C 0.047UF K     |             |
| C128     |         |           | CK73GB1H102K  | CHIP C 1000PF K     |             | C221     |         |           | CK73GB1H471K  | CHIP C 470PF K       |             |
| C129     |         |           | CK73GB1C104K  | CHIP C 0.10UF K     |             | C222     |         |           | CK73GB1E123K  | CHIP C 0.012UF K     |             |
| C135     |         |           | CK73GB1H103K  | CHIP C 0.010UF K    |             | C223     |         |           | C92-0507-05   | CHIP-TAN 4.7UF 6.3WV |             |
| C136     |         |           | CK73GB1H102K  | CHIP C 1000PF K     |             | C225     |         |           | CK73GB1H222K  | CHIP C 2200PF K      |             |
| C138     |         |           | CC73GCH1H330J | CHIP C 33PF J       |             | C226     |         |           | CK73GB1C683K  | CHIP C 0.068UF K     |             |
| C141     |         |           | CK73GB1H471K  | CHIP C 470PF K      |             | C228     |         |           | CK73GB1H471K  | CHIP C 470PF K       |             |
| C142     |         |           | CK73GB1E223K  | CHIP C 0.022UF K    |             | C230     |         |           | CK73GB1H471K  | CHIP C 470PF K       |             |
| C143     |         |           | CK73GB1H102K  | CHIP C 1000PF K     |             | C232     |         |           | CK73GB1H471K  | CHIP C 470PF K       |             |
| C144     |         |           | CK73GB1H392K  | CHIP C 3900PF K     |             | C233     |         |           | C92-0719-05   | ELECTRO 47UF 25WV    |             |
| C145     |         |           | CC73GCH1H060B | CHIP C 6.0PF B      |             | C236     |         |           | CC73GCH1H070B | CHIP C 7.0PF B       |             |
| C146     |         |           | CK73GB1H471K  | CHIP C 470PF K      |             | C237     |         |           | CK73GB1C104K  | CHIP C 0.10UF K      |             |
| C147     |         |           | CK73GB1E223K  | CHIP C 0.022UF K    |             | C239     |         |           | CK73GB1H471K  | CHIP C 470PF K       |             |
| C150     |         |           | CC73GCH1H180J | CHIP C 18PF J       |             | C242     |         |           | CK73GB1H471K  | CHIP C 470PF K       |             |
| C154     |         |           | CK73GB1H471K  | CHIP C 470PF K      |             | C243     |         |           | CK73GB1C104K  | CHIP C 0.10UF K      |             |
| C155     |         |           | CK73GB1H103K  | CHIP C 0.010UF K    |             | C246     |         |           | C92-0719-05   | ELECTRO 47UF 25WV    |             |
| C156     |         |           | CC73GCH1H020B | CHIP C 2.0PF B      |             | C247     |         |           | CC73GCH1H070B | CHIP C 7.0PF B       |             |
| C157     |         |           | CK73GB1H471K  | CHIP C 470PF K      |             | C251,252 |         |           | CK73GB1H471K  | CHIP C 470PF K       |             |
| C160     |         |           | CK73FB1C334K  | CHIP C 0.33UF K     |             | C254     |         |           | C92-0004-05   | CHIP-TAN 1.0UF 16WV  |             |
| C162     |         |           | CC73GCH1H050B | CHIP C 5.0PF B      |             | C255     |         |           | CC73GCH1H0R5B | CHIP C 0.5PF B       |             |
| C163     |         |           | CC73GCH1H120J | CHIP C 12PF J       |             | C256     |         |           | CK73GB1C104K  | CHIP C 0.10UF K      |             |
| C165     |         |           | CK73GB1H103K  | CHIP C 0.010UF K    |             | C262     |         |           | C92-0568-05   | CHIP-TAN 22UF 10WV   |             |
| C166     |         |           | CC73GCH1H1R5B | CHIP C 1.5PF B      |             | C264     |         |           | CK73GB1H471K  | CHIP C 470PF K       |             |
| C168     |         |           | CK73GB1H103K  | CHIP C 0.010UF K    |             | C265     |         |           | C92-0568-05   | CHIP-TAN 22UF 10WV   |             |
| C169     |         |           | CK73GB1H471K  | CHIP C 470PF K      |             | C266     |         |           | CC73GCH1H060B | CHIP C 6.0PF B       |             |
| C170     |         |           | CC73GCH1H050B | CHIP C 5.0PF B      |             | C268     |         |           | C92-0568-05   | CHIP-TAN 22UF 10WV   |             |
| C171     |         |           | CC73GCH1H080B | CHIP C 8.0PF B      |             | C269     |         |           | CK73GB1H103K  | CHIP C 0.010UF K     |             |
| C173     |         |           | CK73GB1C104K  | CHIP C 0.10UF K     |             | C271     |         |           | CK73GB1H103K  | CHIP C 0.010UF K     |             |
| C174     |         |           | CC73GCH1H050B | CHIP C 5.0PF B      |             | C273     |         |           | CC73GCH1HR75B | CHIP C 0.75PF B      |             |
| C176     |         |           | CK73GB1H471K  | CHIP C 470PF K      |             | C274     |         |           | CK73GB1H103K  | CHIP C 0.010UF K     |             |
| C177     |         |           | CC73GCH1H070B | CHIP C 7.0PF B      |             | C275     |         |           | CK73GB1C104K  | CHIP C 0.10UF K      |             |
| C178     |         |           | CK73GB1C104K  | CHIP C 0.10UF K     |             | C277     |         |           | CK73FB1A105K  | CHIP C 1.0UF K       |             |
| C179     |         |           | CK73GB1H471K  | CHIP C 470PF K      |             | C279     |         |           | CK73GB1H471K  | CHIP C 470PF K       |             |
| C180     |         |           | CK73GB1H103J  | CHIP C 0.010UF J    |             | C280     |         |           | C92-0633-05   | CHIP-TAN 22UF 10WV   |             |
| C182     |         |           | CK73GB1C104K  | CHIP C 0.10UF K     |             | C283     |         |           | CK73GB1H471K  | CHIP C 470PF K       |             |
| C184     |         |           | CK73GB1H471K  | CHIP C 470PF K      |             | C284     |         |           | CK73FB1C224K  | CHIP C 0.22UF K      |             |

## PARTS LIST

## TX-RX UNIT (X57-6303-01)

| Ref. No. | Address | New parts | Parts No.     | Description          | Destination | Ref. No. | Address | New parts | Parts No.    | Description                  | Destination |
|----------|---------|-----------|---------------|----------------------|-------------|----------|---------|-----------|--------------|------------------------------|-------------|
| C286     |         |           | CK73GB1C104K  | CHIP C 0.10UF K      |             | C518     |         |           | C92-0507-05  | CHIP-TAN 4.7UF 6.3WV         |             |
| C288     |         |           | C92-0721-05   | ELECTRO 330UF 25WV   |             | C520     |         |           | CK73GB1H102K | CHIP C 1000PF K              |             |
| C289     |         |           | C93-0603-05   | CHIP C 1000PF K      |             | C521     |         |           | CK73GB1H392K | CHIP C 3900PF K              |             |
| C290     |         |           | CK73GB1H471K  | CHIP C 470PF K       |             | C522     |         |           | CK73FB1A105K | CHIP C 1.0UF K               |             |
| C291     |         |           | CC73GCH1H0R5B | CHIP C 0.5PF B       |             | C523     |         |           | C93-0550-05  | CHIP C 1.0PF C               |             |
| C292     |         |           | CC73GCH1H020B | CHIP C 2.0PF B       |             | C524     |         |           | CK73GB1H102K | CHIP C 1000PF K              |             |
| C294,295 |         |           | CK73GB1H471K  | CHIP C 470PF K       |             | C525     |         |           | C93-0550-05  | CHIP C 1.0PF C               |             |
| C296     |         |           | C93-0552-05   | CHIP C 2.0PF C       |             | C526     |         |           | CK73GB1H102K | CHIP C 1000PF K              |             |
| C298,299 |         |           | CK73GB1H471K  | CHIP C 470PF K       |             | TC1,2    |         |           | C05-0245-05  | CERAMIC TRIMMER CAP(10PF)    |             |
| C301     |         |           | C93-0550-05   | CHIP C 1.0PF C       |             | TC3      | *       |           | C05-0399-05  | CERAMIC TRIMMER CAP(6PF)     |             |
| C302     |         |           | C92-0040-05   | CHIP-ELE 47UF 16WV   |             | TC5      | *       |           | C05-0399-05  | CERAMIC TRIMMER CAP(6PF)     |             |
| C303,304 |         |           | CK73GB1H471K  | CHIP C 470PF K       |             | CN1      |         |           | E40-5651-05  | FLAT CABLE CONNECTOR         |             |
| C305     |         |           | C93-0556-05   | CHIP C 6.0PF D       |             | CN5      |         |           | E40-3246-05  | PIN ASSY                     |             |
| C307     |         |           | CK73GB1H471K  | CHIP C 470PF K       |             | CN6      |         |           | E23-0486-05  | TERMINAL                     |             |
| C308     |         |           | C92-0560-05   | CHIP-TAN 10UF 6.3WV  |             | J1       |         |           | E11-0425-05  | 3.5D PHONE JACK(3P)          |             |
| C310     |         |           | CK73GB1H103K  | CHIP C 0.010UF K     |             | CF1      | *       |           | L72-0993-05  | CERAMIC FILTER               |             |
| C312     |         |           | CC73GCH1H0R5B | CHIP C 0.5PF B       |             | CF2      | *       |           | L72-0999-05  | CERAMIC FILTER               |             |
| C313     |         |           | CC73GCH1H020B | CHIP C 2.0PF B       |             | L1       |         |           | L92-0140-05  | FERRITE CHIP                 |             |
| C314     |         |           | CK73GB1C104K  | CHIP C 0.10UF K      |             | L2       | *       |           | L41-1005-08  | SMALL FIXED INDUCTOR         |             |
| C316     |         |           | C92-0516-05   | CHIP-TAN 4.7UF 16WV  |             | L3       |         |           | L92-0138-05  | FERRITE CHIP                 |             |
| C318     |         |           | CK73GB1H471K  | CHIP C 470PF K       |             | L4       |         |           | L92-0140-05  | FERRITE CHIP                 |             |
| C320     |         |           | C92-0722-05   | ELECTRO 470UF 16WV   |             | L5,6     |         |           | L40-2702-86  | SMALL FIXED INDUCTOR(27UH)   |             |
| C323     |         |           | C93-0554-05   | CHIP C 4.0PF C       |             | L7       |         |           | L92-0140-05  | FERRITE CHIP                 |             |
| C324     |         |           | CK73GB1H471K  | CHIP C 470PF K       |             | L8       |         |           | L40-2702-86  | SMALL FIXED INDUCTOR(27UH)   |             |
| C326     |         |           | CK73GB1H471K  | CHIP C 470PF K       |             | L9       |         |           | L40-3378-67  | SMALL FIXED INDUCTOR(33NH)   |             |
| C327     |         |           | CK73GB1H102K  | CHIP C 1000PF K      |             | L10      |         |           | L40-2702-86  | SMALL FIXED INDUCTOR(27UH)   |             |
| C328     |         |           | CK73GB1H471K  | CHIP C 470PF K       |             | L11      |         |           | L40-2778-67  | SMALL FIXED INDUCTOR(27NH)   |             |
| C329     |         |           | CK73GB1H103K  | CHIP C 0.010UF K     |             | L12      |         |           | L40-3381-86  | SMALL FIXED INDUCTOR(0.33UH) |             |
| C330-332 |         |           | CC73GCH1H101J | CHIP C 100PF J       |             | L13      |         |           | L40-2702-86  | SMALL FIXED INDUCTOR(27UH)   |             |
| C333     |         |           | CK73GB1H471K  | CHIP C 470PF K       |             | L14      |         |           | L40-3381-86  | SMALL FIXED INDUCTOR(0.33UH) |             |
| C334     |         |           | CC73GCH1H180J | CHIP C 18PF J        |             | L15      |         |           | L40-2702-86  | SMALL FIXED INDUCTOR(27UH)   |             |
| C335,336 |         |           | CK73GB1C104K  | CHIP C 0.10UF K      |             | L16      |         |           | L92-0140-05  | FERRITE CHIP                 |             |
| C337     |         |           | C92-0507-05   | CHIP-TAN 4.7UF 6.3WV |             | L17      | *       |           | L41-3385-08  | SMALL FIXED INDUCTOR         |             |
| C338     |         |           | CK73GB1C104K  | CHIP C 0.10UF K      |             | L18      |         |           | L92-0140-05  | FERRITE CHIP                 |             |
| C340     |         |           | C92-0560-05   | CHIP-TAN 10UF 6.3WV  |             | L19,20   |         |           | L40-2702-86  | SMALL FIXED INDUCTOR(27UH)   |             |
| C341     |         |           | CK73GB1H471K  | CHIP C 470PF K       |             | L21      | *       |           | L41-2775-06  | SMALL FIXED INDUCTOR         |             |
| C342     |         |           | C92-0507-05   | CHIP-TAN 4.7UF 6.3WV |             | L22      |         |           | L34-4554-05  | COIL                         |             |
| C344-350 |         |           | CK73GB1H471K  | CHIP C 470PF K       |             | L23      |         |           | L92-0140-05  | FERRITE CHIP                 |             |
| C351     |         |           | CK73GB1H102K  | CHIP C 1000PF K      |             | L24      | *       |           | L41-2775-06  | SMALL FIXED INDUCTOR         |             |
| C352,353 |         |           | CK73GB1H471K  | CHIP C 470PF K       |             | L26,27   |         |           | L40-4785-85  | SMALL FIXED INDUCTOR(0.47UH) |             |
| C355     |         |           | CK73GB1C104K  | CHIP C 0.10UF K      |             | L30      |         |           | L34-4604-05  | AIR-CORE COIL                |             |
| C356     |         |           | CK73GB1H103K  | CHIP C 0.010UF K     |             | L31      | *       |           | L41-1875-08  | SMALL FIXED INDUCTOR         |             |
| C358-361 |         |           | CK73GB1H471K  | CHIP C 470PF K       |             | L32      |         |           | L34-4604-05  | AIR-CORE COIL                |             |
| C362     |         |           | CK73GB1C104K  | CHIP C 0.10UF K      |             | L33      | *       |           | L41-2275-08  | SMALL FIXED INDUCTOR         |             |
| C363     |         |           | CC73GCH1H080B | CHIP C 8.0PF B       |             | L36      |         |           | L34-4604-05  | AIR-CORE COIL                |             |
| C364,365 |         |           | CK73GB1H471K  | CHIP C 470PF K       |             | L38      |         |           | L34-4604-05  | AIR-CORE COIL                |             |
| C366     |         |           | CC73GCH1H070B | CHIP C 7.0PF B       |             | L40      |         |           | L34-4478-05  | AIR-CORE COIL                |             |
| C367     |         |           | CK73GB1H471K  | CHIP C 470PF K       |             | L42      |         |           | L34-1185-05  | AIR-CORE COIL                |             |
| C369     |         |           | CK73GB1H471K  | CHIP C 470PF K       |             | L43,44   |         |           | L34-1039-05  | AIR-CORE COIL                |             |
| C371,372 |         |           | CK73GB1H471K  | CHIP C 470PF K       |             | L45      |         |           | L34-4478-05  | AIR-CORE COIL                |             |
| C374     |         |           | C92-0507-05   | CHIP-TAN 4.7UF 6.3WV |             | L46      | *       |           | L41-2775-06  | SMALL FIXED INDUCTOR         |             |
| C375     |         |           | CK73GB1C104K  | CHIP C 0.10UF K      |             | L48,49   |         |           | L34-4604-05  | AIR-CORE COIL                |             |
| C376     |         |           | CK73GB1H471K  | CHIP C 470PF K       |             | L50      |         |           | L40-3975-92  | SMALL FIXED INDUCTOR(39NH)   |             |
| C377     |         |           | C92-0004-05   | CHIP-TAN 1.0UF 16WV  |             | L51      |         |           | L40-1875-92  | SMALL FIXED INDUCTOR(18NH)   |             |
| C378     |         |           | CK73GB1H471K  | CHIP C 470PF K       |             | L54,55   |         |           | L92-0179-05  | FERRITE CHIP                 |             |
| C379     |         |           | CK73GB1C104K  | CHIP C 0.10UF K      |             | X1       |         |           | L77-1868-15  | TCXO(16.8MHZ)                |             |
| C511     |         |           | CK73GB1H471K  | CHIP C 470PF K       |             | X2       |         |           | L77-1867-05  | CRYSTAL RESONATOR(7.159MHZ)  |             |
| C512,513 |         |           | CC73GCH1H101J | CHIP C 100PF J       |             | XF1      | *       |           | L71-0591-05  | MCF(49.95MHZ)                |             |
| C514     |         |           | C92-0004-05   | CHIP-TAN 1.0UF 16WV  |             |          |         |           |              |                              |             |
| C515     |         |           | CK73GB1H471K  | CHIP C 470PF K       |             |          |         |           |              |                              |             |

## PARTS LIST

TX-RX UNIT (X57-6303-01)

| Ref. No. | Address | New parts | Parts No.    | Description         | Destination | Ref. No. | Address | New parts | Parts No.    | Description         | Destination |
|----------|---------|-----------|--------------|---------------------|-------------|----------|---------|-----------|--------------|---------------------|-------------|
| R1       |         |           | RK73GB1J332J | CHIP R 3.3K J 1/16W |             | R97      |         |           | RK73GB1J102J | CHIP R 1.0K J 1/16W |             |
| R2       |         |           | RK73GB1J102J | CHIP R 1.0K J 1/16W |             | R98      |         |           | RK73GB1J221J | CHIP R 220 J 1/16W  |             |
| R3       |         |           | R92-1252-05  | CHIP R 0 OHM        |             | R99      |         |           | RK73GB1J151J | CHIP R 150 J 1/16W  |             |
| R4,5     |         |           | RK73GB1J101J | CHIP R 100 J 1/16W  |             | R100     |         |           | RK73GB1J102J | CHIP R 1.0K J 1/16W |             |
| R6,7     |         |           | R92-1252-05  | CHIP R 0 OHM        |             | R101     |         |           | RK73GB1J124J | CHIP R 120K J 1/16W |             |
| R10,11   |         |           | RK73GB1J102J | CHIP R 1.0K J 1/16W |             | R102     |         |           | RK73GB1J223J | CHIP R 22K J 1/16W  |             |
| R12      |         |           | RK73GB1J152J | CHIP R 1.5K J 1/16W |             | R103     |         |           | RK73GB1J182J | CHIP R 1.8K J 1/16W |             |
| R13      |         |           | RK73GB1J102J | CHIP R 1.0K J 1/16W |             | R104     |         |           | R92-1252-05  | CHIP R 0 OHM        |             |
| R15      |         |           | RK73GB1J100J | CHIP R 10 J 1/16W   |             | R106     |         |           | RK73GB1J472J | CHIP R 4.7K J 1/16W |             |
| R18      |         |           | RK73GB1J913J | CHIP R 91K J 1/16W  |             | R107     |         |           | RK73GB1J101J | CHIP R 100 J 1/16W  |             |
| R19      |         |           | RK73GB1J683J | CHIP R 68K J 1/16W  |             | R108     |         |           | RK73GB1J274J | CHIP R 270K J 1/16W |             |
| R20      |         |           | RK73GB1J104J | CHIP R 100K J 1/16W |             | R109     |         |           | R92-1252-05  | CHIP R 0 OHM        |             |
| R21      |         |           | RK73GB1J152J | CHIP R 1.5K J 1/16W |             | R111     |         |           | RK73GB1J222J | CHIP R 2.2K J 1/16W |             |
| R22      |         |           | RK73GB1J122J | CHIP R 1.2K J 1/16W |             | R113     |         |           | RK73GB1J183J | CHIP R 18K J 1/16W  |             |
| R23      |         |           | RK73GB1J102J | CHIP R 1.0K J 1/16W |             | R115     |         |           | RK73GB1J102J | CHIP R 1.0K J 1/16W |             |
| R24      |         |           | RK73GB1J754J | CHIP R 750K J 1/16W |             | R117     |         |           | RK73GB1J102J | CHIP R 1.0K J 1/16W |             |
| R26,27   |         |           | RK73GH1J153D | CHIP R 15K D 1/16W  |             | R118     |         |           | RK73GB1J473J | CHIP R 47K J 1/16W  |             |
| R28      |         |           | R92-1252-05  | CHIP R 0 OHM        |             | R119     |         |           | RK73GB1J102J | CHIP R 1.0K J 1/16W |             |
| R30      |         |           | RK73GB1J152J | CHIP R 1.5K J 1/16W |             | R120     |         |           | RK73GB1J473J | CHIP R 47K J 1/16W  |             |
| R31      |         |           | RK73GB1J244J | CHIP R 240K J 1/16W |             | R122,123 |         |           | RK73GB1J473J | CHIP R 47K J 1/16W  |             |
| R32      |         |           | R92-1252-05  | CHIP R 0 OHM        |             | R124     |         |           | RK73GB1J472J | CHIP R 4.7K J 1/16W |             |
| R33      |         |           | RK73GB1J102J | CHIP R 1.0K J 1/16W |             | R127     |         |           | RK73GB1J104J | CHIP R 100K J 1/16W |             |
| R34      |         |           | RK73GB1J123J | CHIP R 12K J 1/16W  |             | R128     |         |           | RK73GB1J105J | CHIP R 1.0M J 1/16W |             |
| R36      |         |           | RK73GB1J471J | CHIP R 470 J 1/16W  |             | R130     |         |           | RK73GB1J332J | CHIP R 3.3K J 1/16W |             |
| R37-39   |         |           | RK73GB1J103J | CHIP R 10K J 1/16W  |             | R132     |         |           | RK73GB1J471J | CHIP R 470 J 1/16W  |             |
| R40      |         |           | RK73GB1J224J | CHIP R 220K J 1/16W |             | R133     |         |           | RK73GB1J101J | CHIP R 100 J 1/16W  |             |
| R41,42   |         |           | RK73GB1J183J | CHIP R 18K J 1/16W  |             | R134     |         |           | R92-1252-05  | CHIP R 0 OHM        |             |
| R43      |         |           | RK73GB1J223J | CHIP R 22K J 1/16W  |             | R135-140 |         |           | RK73GB1J102J | CHIP R 1.0K J 1/16W |             |
| R44      |         |           | R92-1252-05  | CHIP R 0 OHM        |             | R141     |         |           | RK73GB1J152J | CHIP R 1.5K J 1/16W |             |
| R45      |         |           | RK73GB1J334J | CHIP R 330K J 1/16W |             | R142-144 |         |           | RK73GB1J102J | CHIP R 1.0K J 1/16W |             |
| R46      |         |           | RK73GB1J102J | CHIP R 1.0K J 1/16W |             | R145     |         |           | R92-1252-05  | CHIP R 0 OHM        |             |
| R47      |         |           | RK73GB1J473J | CHIP R 47K J 1/16W  |             | R146     |         |           | RK73GB1J334J | CHIP R 330K J 1/16W |             |
| R48      |         |           | RK73GB1J683J | CHIP R 68K J 1/16W  |             | R147     |         |           | RK73GB1J124J | CHIP R 120K J 1/16W |             |
| R49      |         |           | RK73GB1J823J | CHIP R 82K J 1/16W  |             | R149     |         |           | RK73GB1J104J | CHIP R 100K J 1/16W |             |
| R50      |         |           | RK73GB1J153J | CHIP R 15K J 1/16W  |             | R150     |         |           | RK73GB1J102J | CHIP R 1.0K J 1/16W |             |
| R51      |         |           | RK73GB1J102J | CHIP R 1.0K J 1/16W |             | R151     |         |           | RK73GB1J103J | CHIP R 10K J 1/16W  |             |
| R52      |         |           | RK73GB1J683J | CHIP R 68K J 1/16W  |             | R152     |         |           | RK73GB1J473J | CHIP R 47K J 1/16W  |             |
| R53      |         |           | RK73GB1J823J | CHIP R 82K J 1/16W  |             | R153     |         |           | RK73GB1J561J | CHIP R 560 J 1/16W  |             |
| R54      |         |           | RK73GB1J103J | CHIP R 10K J 1/16W  |             | R154     |         |           | RK73GB1J471J | CHIP R 470 J 1/16W  |             |
| R55      |         |           | RK73GB1J222J | CHIP R 2.2K J 1/16W |             | R155     |         |           | RK73GB1J472J | CHIP R 4.7K J 1/16W |             |
| R56      |         |           | RK73GB1J152J | CHIP R 1.5K J 1/16W |             | R156     |         |           | RK73GB1J101J | CHIP R 100 J 1/16W  |             |
| R57      |         |           | RK73GB1J683J | CHIP R 68K J 1/16W  |             | R158     |         |           | RK73GB1J102J | CHIP R 1.0K J 1/16W |             |
| R58      |         |           | RK73GB1J473J | CHIP R 47K J 1/16W  |             | R159     |         |           | RK73GB1J101J | CHIP R 100 J 1/16W  |             |
| R59      |         |           | RK73GB1J223J | CHIP R 22K J 1/16W  |             | R160     |         |           | RK73GB1J102J | CHIP R 1.0K J 1/16W |             |
| R60      |         |           | RK73GB1J103J | CHIP R 10K J 1/16W  |             | R161     |         |           | RK73GB1J333J | CHIP R 33K J 1/16W  |             |
| R61      |         |           | RK73GB1J473J | CHIP R 47K J 1/16W  |             | R162     |         |           | RK73GB1J102J | CHIP R 1.0K J 1/16W |             |
| R62,63   |         |           | RK73GB1J104J | CHIP R 100K J 1/16W |             | R163     |         |           | RK73GB1J561J | CHIP R 560 J 1/16W  |             |
| R64      |         |           | RK73GB1J154J | CHIP R 150K J 1/16W |             | R164     |         |           | RK73GB1J473J | CHIP R 47K J 1/16W  |             |
| R67      |         |           | RK73GB1J223J | CHIP R 22K J 1/16W  |             | R165     |         |           | RK73GB1J333J | CHIP R 33K J 1/16W  |             |
| R70      |         |           | RK73GB1J473J | CHIP R 47K J 1/16W  |             | R166     |         |           | RK73GB1J102J | CHIP R 1.0K J 1/16W |             |
| R72      |         |           | RK73GB1J154J | CHIP R 150K J 1/16W |             | R167     |         |           | RK73GB1J470J | CHIP R 47 J 1/16W   |             |
| R73,74   |         |           | RK73GB1J103J | CHIP R 10K J 1/16W  |             | R168     |         |           | RK73GB1J333J | CHIP R 33K J 1/16W  |             |
| R76      |         |           | RK73GB1J101J | CHIP R 100 J 1/16W  |             | R169     |         |           | RK73GB1J222J | CHIP R 2.2K J 1/16W |             |
| R77,78   |         |           | RK73GB1J103J | CHIP R 10K J 1/16W  |             | R172     |         |           | RK73GB1J102J | CHIP R 1.0K J 1/16W |             |
| R80-85   |         |           | RK73GB1J102J | CHIP R 1.0K J 1/16W |             | R173     |         |           | RK73GB1J104J | CHIP R 100K J 1/16W |             |
| R86      |         |           | RK73GB1J101J | CHIP R 100 J 1/16W  |             | R174     |         |           | RK73GB1J220J | CHIP R 22 J 1/16W   |             |
| R87      |         |           | RK73GB1J223J | CHIP R 22K J 1/16W  |             | R175     |         |           | RK73GB1J181J | CHIP R 180 J 1/16W  |             |
| R88      |         |           | RK73GB1J101J | CHIP R 100 J 1/16W  |             | R176     |         |           | RK73GB1J823J | CHIP R 82K J 1/16W  |             |
| R89      |         |           | RK73GB1J104J | CHIP R 100K J 1/16W |             | R177     |         |           | RK73GB1J102J | CHIP R 1.0K J 1/16W |             |
| R94      |         |           | RK73GB1J472J | CHIP R 4.7K J 1/16W |             | R178     |         |           | RK73GB1J152J | CHIP R 1.5K J 1/16W |             |

## PARTS LIST

### TX-RX UNIT (X57-6303-01)

| Ref. No. | Address | New parts | Parts No.    | Description         | Destination | Ref. No. | Address | New parts | Parts No.    | Description         | Destination |
|----------|---------|-----------|--------------|---------------------|-------------|----------|---------|-----------|--------------|---------------------|-------------|
| R179     |         |           | RK73GB1J154J | CHIP R 150K J 1/16W |             | R260     |         |           | RK73GB1J473J | CHIP R 47K J 1/16W  |             |
| R181     |         |           | RK73GB1J102J | CHIP R 1.0K J 1/16W |             | R261     |         |           | RK73GB1J123J | CHIP R 12K J 1/16W  |             |
| R183     |         |           | RK73GB1J101J | CHIP R 100 J 1/16W  |             | R262     |         |           | R92-1215-05  | CHIP R 470 J 1/2W   |             |
| R184     |         |           | R92-1252-05  | CHIP R 0 OHM        |             | R263     |         |           | RK73GB1J682J | CHIP R 6.8K J 1/16W |             |
| R185     |         |           | RK73GB1J471J | CHIP R 470 J 1/16W  |             | R264     |         |           | RK73GB1J391J | CHIP R 390 J 1/16W  |             |
| R186     |         |           | RK73GB1J100J | CHIP R 10 J 1/16W   |             | R265     |         |           | RK73GB1J472J | CHIP R 4.7K J 1/16W |             |
| R188     |         |           | RK73GB1J104J | CHIP R 100K J 1/16W |             | R266     |         |           | RK73GB1J334J | CHIP R 330K J 1/16W |             |
| R189     |         |           | RK73GH1J124D | CHIP R 120K D 1/16W |             | R267     |         |           | RK73GB1J223J | CHIP R 22K J 1/16W  |             |
| R190     |         |           | RK73GB1J123J | CHIP R 12K J 1/16W  |             | R268     |         |           | R92-0670-05  | CHIP R 0 OHM        |             |
| R191     |         |           | RK73GH1J913D | CHIP R 91K D 1/16W  |             | R271     |         |           | RK73GB1J472J | CHIP R 4.7K J 1/16W |             |
| R192     |         |           | RK73GB1J562J | CHIP R 5.6K J 1/16W |             | R273     |         |           | RK73GB1J102J | CHIP R 1.0K J 1/16W |             |
| R194     |         |           | RK73GB1J153J | CHIP R 15K J 1/16W  |             | R274     |         |           | RK73GB1J223J | CHIP R 22K J 1/16W  |             |
| R195     |         |           | RK73GH1J562D | CHIP R 5.6K D 1/16W |             | R275     |         |           | RK73GB1J333J | CHIP R 33K J 1/16W  |             |
| R197     |         |           | RK73GB1J332J | CHIP R 3.3K J 1/16W |             | R276-278 |         |           | RK73GB1J102J | CHIP R 1.0K J 1/16W |             |
| R198     |         |           | RK73GB1J100J | CHIP R 10 J 1/16W   |             | R279     |         | *         | RK73GJ1J393D | CHIP R 39K D 1/16W  |             |
| R201     |         |           | RK73GB1J152J | CHIP R 1.5K J 1/16W |             | R280     |         |           | RK73GH1J274D | CHIP R 270K D 1/16W |             |
| R202     |         |           | RK73GB1J332J | CHIP R 3.3K J 1/16W |             | R281     |         |           | RK73GB1J102J | CHIP R 1.0K J 1/16W |             |
| R203     |         |           | RK73FB2A331J | CHIP R 330 J 1/10W  |             | R282     |         |           | RK73GB1J684J | CHIP R 680K J 1/16W |             |
| R204     |         |           | RK73GB1J104J | CHIP R 100K J 1/16W |             | R283     |         |           | RK73GB1J184J | CHIP R 180K J 1/16W |             |
| R205     |         |           | RK73FB2A100J | CHIP R 10 J 1/10W   |             | R285     |         |           | RK73GB1J681J | CHIP R 680 J 1/16W  |             |
| R207     |         |           | RK73GB1J823J | CHIP R 82K J 1/16W  |             | R286     |         |           | RK73GB1J124J | CHIP R 120K J 1/16W |             |
| R208     |         |           | RK73GB1J151J | CHIP R 150 J 1/16W  |             | R287     |         |           | RK73GB1J472J | CHIP R 4.7K J 1/16W |             |
| R209     |         |           | RK73GB1J394J | CHIP R 390K J 1/16W |             | R288,289 |         |           | R92-1252-05  | CHIP R 0 OHM        |             |
| R210     |         |           | RK73GB1J334J | CHIP R 330K J 1/16W |             | R291     |         |           | RK73GB1J124J | CHIP R 120K J 1/16W |             |
| R211     |         |           | RK73GB1J473J | CHIP R 47K J 1/16W  |             | R293     |         |           | RK73GB1J221J | CHIP R 220 J 1/16W  |             |
| R213     |         |           | R92-0685-05  | CHIP R 22 J 1/2W    |             | R294     |         |           | RK73GB1J681J | CHIP R 680 J 1/16W  |             |
| R214     |         |           | RK73GB1J562J | CHIP R 5.6K J 1/16W |             | R295,296 |         |           | R92-1252-05  | CHIP R 0 OHM        |             |
| R215     |         |           | RK73GB1J104J | CHIP R 100K J 1/16W |             | R298     |         |           | RK73GB1J101J | CHIP R 100 J 1/16W  |             |
| R216     |         |           | RK73GB1J562J | CHIP R 5.6K J 1/16W |             | R300     |         |           | R92-1252-05  | CHIP R 0 OHM        |             |
| R217     |         |           | RK73GB1J474J | CHIP R 470K J 1/16W |             | R301     |         |           | RK73GB1J104J | CHIP R 100K J 1/16W |             |
| R218     |         |           | RK73GB1J394J | CHIP R 390K J 1/16W |             | R302     |         |           | RK73GB1J683J | CHIP R 68K J 1/16W  |             |
| R219     |         |           | RK73GB1J105J | CHIP R 1.0M J 1/16W |             | R303     |         |           | RK73GB1J334J | CHIP R 330K J 1/16W |             |
| R221     |         |           | RK73FB2A471J | CHIP R 470 J 1/10W  |             | R304     |         |           | RK73GB1J224J | CHIP R 220K J 1/16W |             |
| R224     |         |           | RK73FB2A120J | CHIP R 12 J 1/10W   |             | R305     |         |           | RK73GB1J913J | CHIP R 91K J 1/16W  |             |
| R227     |         |           | RK73GB1J223J | CHIP R 22K J 1/16W  |             | R306     |         |           | RK73GB1J334J | CHIP R 330K J 1/16W |             |
| R228     |         |           | RK73GB1J184J | CHIP R 180K J 1/16W |             | R307     |         |           | RK73GB1J333J | CHIP R 33K J 1/16W  |             |
| R229     |         |           | RK73GB1J223J | CHIP R 22K J 1/16W  |             | R308     |         |           | R92-1252-05  | CHIP R 0 OHM        |             |
| R232     |         |           | RK73GB1J184J | CHIP R 180K J 1/16W |             | R310     |         |           | RK73GB1J104J | CHIP R 100K J 1/16W |             |
| R233     |         |           | RK73FB2A471J | CHIP R 470 J 1/10W  |             | R311     |         |           | RK73GB1J101J | CHIP R 100 J 1/16W  |             |
| R234     |         |           | RK73GB1J153J | CHIP R 15K J 1/16W  |             | R313     |         |           | RK73GB1J821J | CHIP R 820 J 1/16W  |             |
| R236     |         |           | R92-1213-05  | CHIP R 100 J 1/2W   |             | R316     |         |           | R92-1252-05  | CHIP R 0 OHM        |             |
| R237     |         |           | RK73GB1J104J | CHIP R 100K J 1/16W |             | R318     |         |           | RK73FB2A332J | CHIP R 3.3K J 1/10W |             |
| R238     |         |           | RK73GB1J153J | CHIP R 15K J 1/16W  |             | R319,320 |         |           | RK73GB1J474J | CHIP R 470K J 1/16W |             |
| R239     |         |           | RK73GB1J472J | CHIP R 4.7K J 1/16W |             | R321     |         |           | R92-1252-05  | CHIP R 0 OHM        |             |
| R240     |         |           | RK73FB2A222J | CHIP R 2.2K J 1/10W |             | R322     |         |           | RK73GB1J683J | CHIP R 68K J 1/16W  |             |
| R241     |         |           | RK73GB1J334J | CHIP R 330K J 1/16W |             | R323     |         |           | R92-1252-05  | CHIP R 0 OHM        |             |
| R242     |         |           | RK73GB1J472J | CHIP R 4.7K J 1/16W |             | R324,325 |         |           | RK73GB1J102J | CHIP R 1.0K J 1/16W |             |
| R243     |         |           | RK73GB1J103J | CHIP R 10K J 1/16W  |             | R326     |         |           | RK73GB1J333J | CHIP R 33K J 1/16W  |             |
| R244     |         |           | RK73GB1J682J | CHIP R 6.8K J 1/16W |             | R327     |         |           | RK73GB1J102J | CHIP R 1.0K J 1/16W |             |
| R245,246 |         |           | RK73GB1J104J | CHIP R 100K J 1/16W |             | R328     |         |           | RK73GB1J472J | CHIP R 4.7K J 1/16W |             |
| R247     |         |           | RK73GB1J103J | CHIP R 10K J 1/16W  |             | R329     |         |           | RK73GB1J474J | CHIP R 470K J 1/16W |             |
| R248     |         |           | RK73GB1J473J | CHIP R 47K J 1/16W  |             | R330     |         |           | RK73GB1J394J | CHIP R 390K J 1/16W |             |
| R249     |         |           | RK73GB1J102J | CHIP R 1.0K J 1/16W |             | R332     |         |           | R92-0679-05  | CHIP R 0 OHM        |             |
| R250     |         |           | RK73GB1J223J | CHIP R 22K J 1/16W  |             | R335     |         |           | RK73GB1J472J | CHIP R 4.7K J 1/16W |             |
| R251     |         |           | RK73GB1J273J | CHIP R 27K J 1/16W  |             | R336     |         |           | RK73GB1J473J | CHIP R 47K J 1/16W  |             |
| R252     |         |           | RK73GB1J152J | CHIP R 1.5K J 1/16W |             | D1-4     |         |           | DA221        | DIODE               |             |
| R254,255 |         |           | RK73GB1J473J | CHIP R 47K J 1/16W  |             | D6       |         |           | MA2S111      | DIODE               |             |
| R256     |         |           | RK73GB1J104J | CHIP R 100K J 1/16W |             | D7       |         |           | HZU5ALL      | DIODE               |             |
| R257     |         |           | R92-1261-05  | CHIP R 150 J 1/2W   |             | D9-12    |         |           | MA2S304      | VARI CAP            |             |
| R258     |         |           | RK73GB1J104J | CHIP R 100K J 1/16W |             | D13      |         |           | DAN222       | DIODE               |             |

## PARTS LIST

TX-RX UNIT (X57-6303-01)

| Ref. No. | Address | New parts | Parts No.     | Description        | Destination | Ref. No. | Address | New parts | Parts No.    | Description        | Destination |
|----------|---------|-----------|---------------|--------------------|-------------|----------|---------|-----------|--------------|--------------------|-------------|
| D14      |         |           | MA360         | VARI CAP           |             | Q27      |         |           | 2SC2412K     | TRANSISTOR         |             |
| D15      |         |           | DAN222        | DIODE              |             | Q29,30   |         |           | KRC102S      | DIGITAL TRANSISTOR |             |
| D16      |         |           | MA2S111       | DIODE              |             | Q31      |         |           | 2SA1745(6,7) | TRANSISTOR         |             |
| D18      |         |           | MA742         | DIODE              |             | Q32      |         |           | DTC363EU     | DIGITAL TRANSISTOR |             |
| D19      |         |           | DAN235E       | DIODE              |             | Q33      |         |           | KTA1664(Y)   | TRANSISTOR         |             |
| D21,22   |         |           | HVC350B       | VARI CAP           |             | Q34,35   |         |           | KRC102S      | DIGITAL TRANSISTOR |             |
| D23      |         |           | DA221         | DIODE              |             | Q37      |         |           | 2SK1824      | FET                |             |
| D24      |         |           | MA742         | DIODE              |             | Q38      |         | *         | KRC404RTK    | DIGITAL TRANSISTOR |             |
| D25,26   |         |           | HVC350B       | VARI CAP           |             | Q39      |         |           | 2SC5108(Y)   | TRANSISTOR         |             |
| D27      |         |           | MA2S111       | DIODE              |             | Q41      |         |           | 2SC4919      | TRANSISTOR         |             |
| D28      |         |           | HVC350B       | VARI CAP           |             | Q42      |         |           | 2SA1641(S,T) | TRANSISTOR         |             |
| D30      |         |           | MA4PH633      | DIODE              |             | Q43      |         |           | 2SK1824      | FET                |             |
| D31,32   |         |           | XB15A709      | DIODE              |             | Q101     |         |           | KTA1046(Y)   | TRANSISTOR         |             |
| D34      |         |           | MA742         | DIODE              |             | TH1-3    |         |           | S1R104J475H  | THERMISTOR         |             |
| D36      |         |           | MA742         | DIODE              |             | TH5      |         |           | S1R104J475H  | THERMISTOR         |             |
| D38      |         |           | ZSH5MA27      | SURGE ABSORBER     |             |          |         |           |              |                    |             |
| D39      |         |           | 02DZ18(X,Y)   | ZENER DIODE        |             |          |         |           |              |                    |             |
| D41      |         | *         | 1812L110PR    | VARISTOR           |             |          |         |           |              |                    |             |
| D43      |         |           | DAN222        | DIODE              |             |          |         |           |              |                    |             |
| D44      |         |           | 1SS372        | DIODE              |             |          |         |           |              |                    |             |
| IC1      |         |           | MB15A02       | MOS IC             |             |          |         |           |              |                    |             |
| IC3      |         |           | M62363FP      | MOS IC             |             |          |         |           |              |                    |             |
| IC4      |         |           | NJM2902V      | MOS IC             |             |          |         |           |              |                    |             |
| IC5      |         |           | TK14489V      | BI-POLAR IC        |             |          |         |           |              |                    |             |
| IC6      |         | *         | 784214AGC141  | MPU                |             |          |         |           |              |                    |             |
| IC7      |         |           | 24LC08BT-ISN  | ROM IC             |             |          |         |           |              |                    |             |
| IC9      |         |           | LC73872M      | MOS IC             |             |          |         |           |              |                    |             |
| IC10     |         |           | NJM2902V      | MOS IC             |             |          |         |           |              |                    |             |
| IC11     |         |           | NJM2904V      | MOS IC             |             |          |         |           |              |                    |             |
| IC12     |         |           | TA75S01F      | MOS IC             |             |          |         |           |              |                    |             |
| IC14     |         |           | NJM78L05UA    | BI-POLAR IC        |             |          |         |           |              |                    |             |
| IC15     |         |           | PST9140NR     | MOS IC             |             |          |         |           |              |                    |             |
| IC17     |         |           | NJM78L05UA    | BI-POLAR IC        |             |          |         |           |              |                    |             |
| IC18     |         |           | PST9140NR     | MOS IC             |             |          |         |           |              |                    |             |
| IC19     |         |           | TC7W74FU      | MOS IC             |             |          |         |           |              |                    |             |
| IC20     |         | *         | KIA7808AF     | ANALOG IC          |             |          |         |           |              |                    |             |
| IC21     |         |           | NJM2100V      | MOS IC             |             |          |         |           |              |                    |             |
| IC22     |         |           | NJM2904V      | MOS IC             |             |          |         |           |              |                    |             |
| IC101    |         |           | S-AU27AM(K3)  | POWER MODULE       |             |          |         |           |              |                    |             |
| IC102    |         |           | LA4600        | AF POWER AMP       |             |          |         |           |              |                    |             |
| Q2       |         |           | 2SJ243        | FET                |             |          |         |           |              |                    |             |
| Q3       |         |           | 2SC4649(N,P)  | TRANSISTOR         |             |          |         |           |              |                    |             |
| Q4       |         |           | 2SA1832(GR)   | TRANSISTOR         |             |          |         |           |              |                    |             |
| Q5       |         |           | 2SC4738(GR)   | TRANSISTOR         |             |          |         |           |              |                    |             |
| Q6       |         |           | 2SC4649(N,P)  | TRANSISTOR         |             |          |         |           |              |                    |             |
| Q7       |         |           | 2SJ243        | FET                |             |          |         |           |              |                    |             |
| Q10,11   |         |           | 2SK508NV(K52) | FET                |             |          |         |           |              |                    |             |
| Q12      |         |           | KRX102U       | TRANSISTOR         |             |          |         |           |              |                    |             |
| Q13      |         |           | 2SK1824       | FET                |             |          |         |           |              |                    |             |
| Q14      |         |           | 2SC4617(S)    | TRANSISTOR         |             |          |         |           |              |                    |             |
| Q15      |         |           | 2SC5108(Y)    | TRANSISTOR         |             |          |         |           |              |                    |             |
| Q16      |         | *         | KRC414RTK     | DIGITAL TRANSISTOR |             |          |         |           |              |                    |             |
| Q18      |         |           | 2SC2412K      | TRANSISTOR         |             |          |         |           |              |                    |             |
| Q19,20   |         |           | 2SC5108(Y)    | TRANSISTOR         |             |          |         |           |              |                    |             |
| Q21      |         | *         | 3SK255        | FET                |             |          |         |           |              |                    |             |
| Q22      |         |           | 2SK1824       | FET                |             |          |         |           |              |                    |             |
| Q23      |         |           | 2SC3357       | TRANSISTOR         |             |          |         |           |              |                    |             |
| Q24      |         |           | 2SC4617(S)    | TRANSISTOR         |             |          |         |           |              |                    |             |
| Q25      |         |           | 2SC3357       | TRANSISTOR         |             |          |         |           |              |                    |             |
| Q26      |         | *         | 3SK255        | FET                |             |          |         |           |              |                    |             |



# TK-8108

## EXPLODED VIEW

- A N67-3008-46 PAN HEAD SEMS SCREW
- B N87-2606-46 BRAZIER HEAD TAPTITE SCREW
- C N87-2614-46 BRAZIER HEAD TAPTITE SCREW

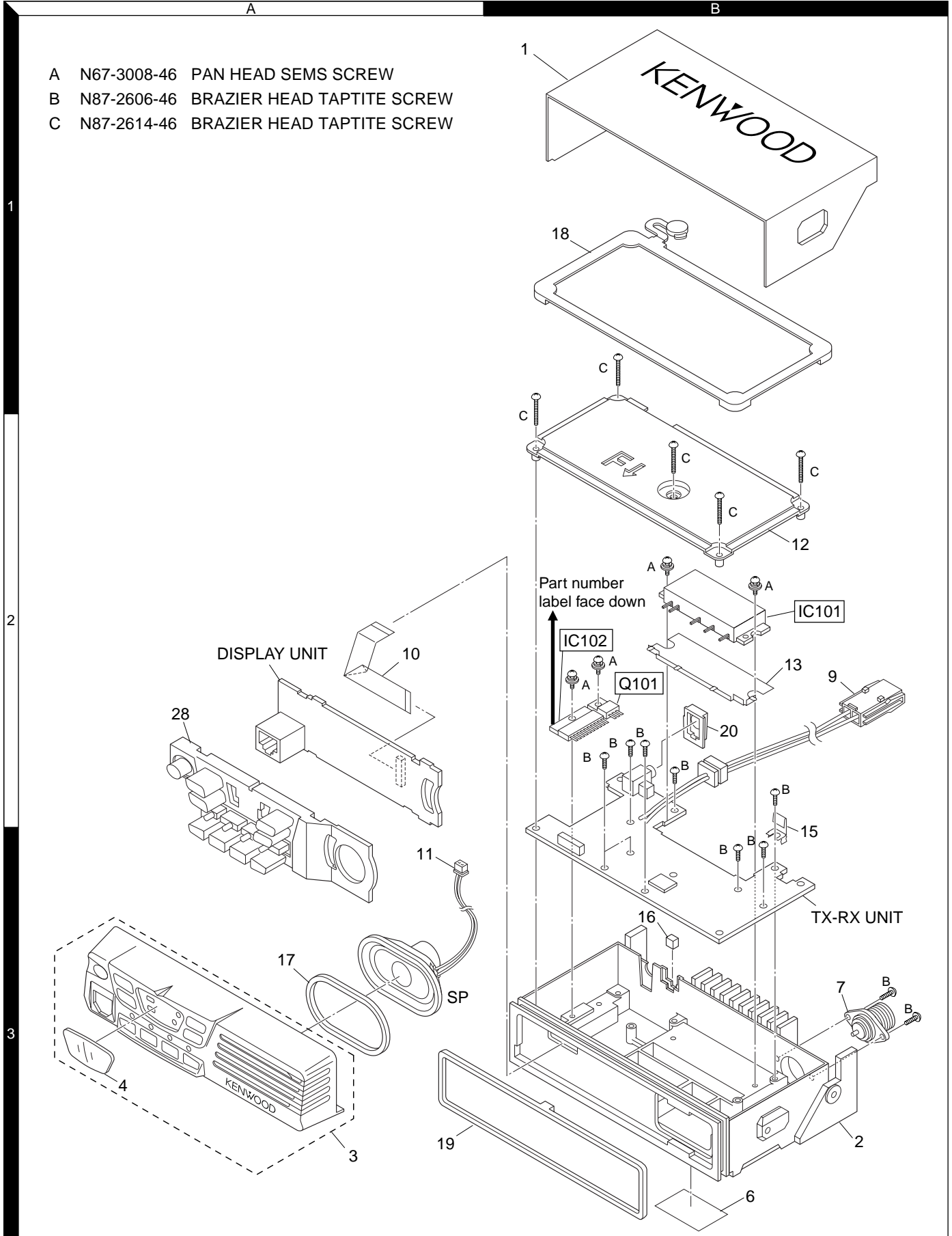

## PACKING

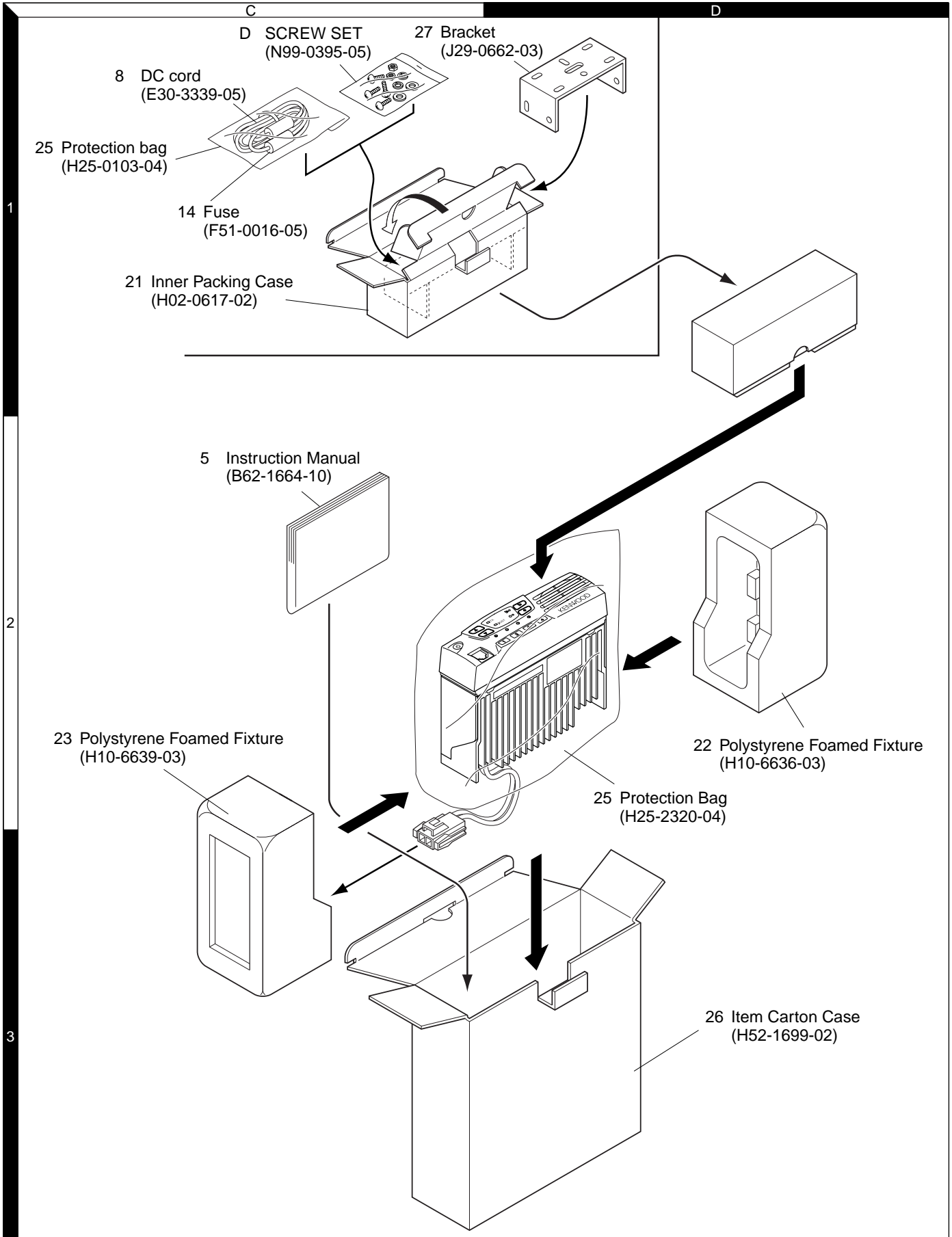

Parts with the exploded numbers larger than 700 are not supplied.

## ADJUSTMENT

### Test Equipment Required for Alignment

| Test Equipment                        | Major Specifications   |  |
|---------------------------------------|--|--|
| 1. Standard Signal Generator (SSG)    | Frequency Range<br>Modulation<br>Output                          | 400 to 520MHz<br>Frequency modulation and external modulation<br>-127dBm/0.1µV to greater than -7dBm/100mV |
| 2. Power Meter                        | Input Impedance<br>Operation Frequency<br>Measurement Capability | 50<br>400 to 520MHz or more<br>Vicinity of 100W  |
| 3. Deviation Meter                    | Frequency Range  | 400 to 520MHz  |
| 4. Digital Volt Meter (DVM)           | Measuring Range<br>Accuracy                                      | 1 to 20V DC<br>High input impedance for minimum circuit loading  |
| 5. Oscilloscope                       |  | DC through 30MHz   |
| 6. High Sensitivity Frequency Counter | Frequency Range<br>Frequency Stability                           | 10Hz to 1000MHz<br>0.2ppm or less  |
| 7. Ammeter                            |  | 20A  |
| 8. AF Volt Meter (AF VTVM)            | Frequency Range<br>Voltage Range                                 | 50Hz to 10kHz<br>1mV to 3V   |
| 9. Audio Generator (AG)               | Frequency Range<br>Output  | 20Hz to 20kHz or more<br>0 to 1V   |
| 10. Distortion Meter                  | Capability<br>Input Level  | 3% or less at 1kHz<br>50mV to 10Vrms   |
| 11. 4 Dummy Load                      |  | Approx. 4 , 10W or more  |
| 12. Regulated Power Supply            |  | 13.6V, approx. 20A (adjustable from 9 to 17V)<br>Useful if ammeter reequipped                              |
| 13. Spectrum Analyzer                 | Center frequency   | 50KHz to 600MHz  |
| 14. Tracking Generator                | Output Voltage   | 100mV or more  |

### Tuning cable (E30-3383-05)

Adapter cable (E30-3383-05) is required for injecting an audio if PC tuning is used. See "PC Mode" section for the connection.

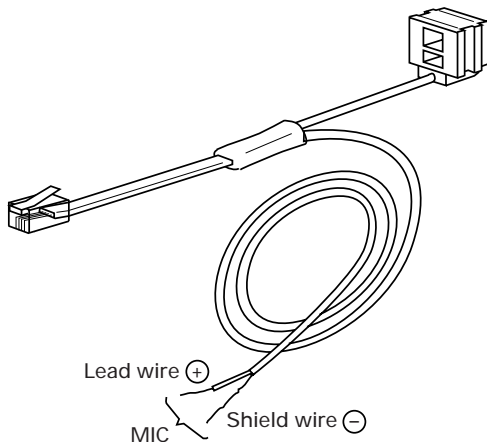

### Test cable for microphone input (E30-3360-08)

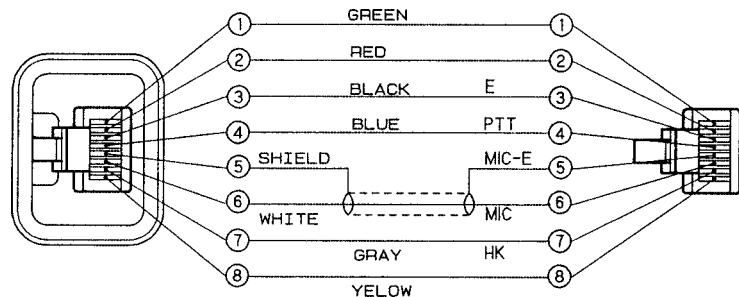

### MIC connector (Front view)

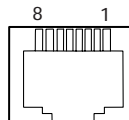

- 1 : BLC
- 2 : PSB
- 3 : E
- 4 : PTT
- 5 : ME
- 6 : MIC
- 7 : HOOK
- 8 : CM

## ADJUSTMENT

### Adjustment Location

#### ■ Switch

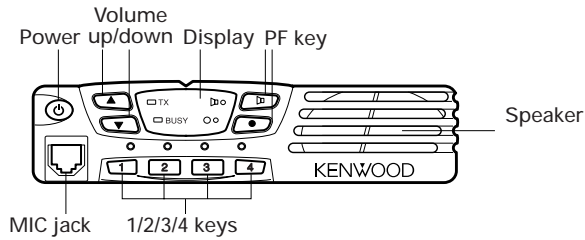

#### ■ Adjustment Point

##### • Component Side View

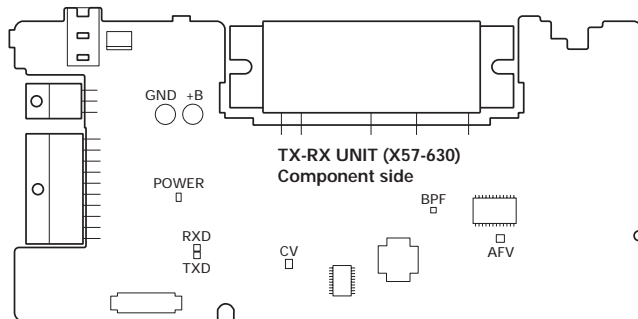

##### • Foil Side View

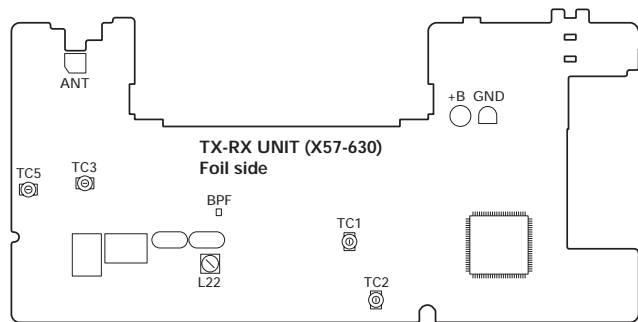

#### ■ Note

##### • EEPROM

The tuning data (Deviation, Squelch, etc.) for the EEPROM, is stored in memory. When parts are changed, readjust the transceiver.

##### • AF PA IC (IC102)

How to mounting the IC102.

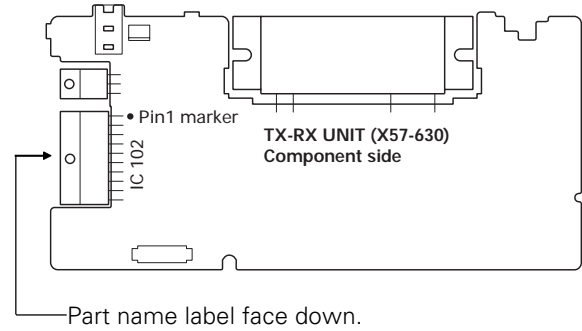

##### • SPEAKER CABLE

The speaker cable should be formed before mounting the shield cover as below.

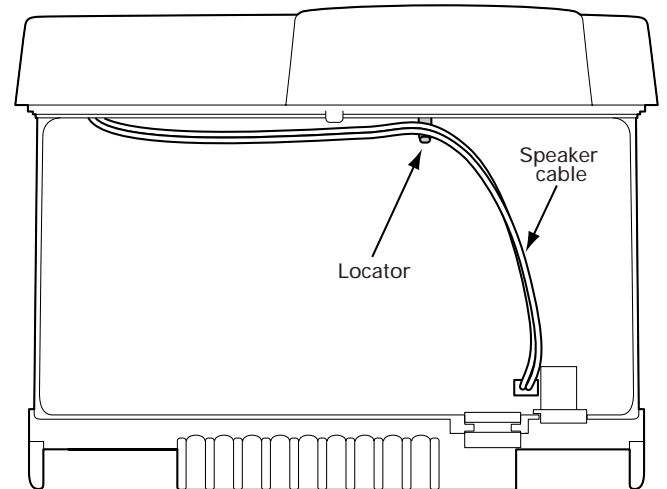

##### • FUSE

To mount the Fuse, the cable terminal direction must be as follows.

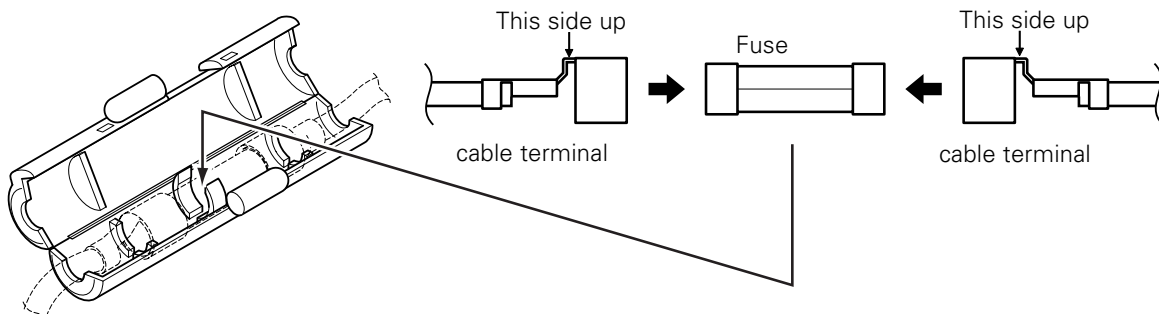

## ADJUSTMENT

Use KPG-70D programming software for adjustment of the next items.

### PCB Section

| Item                   | Condition  | Measurement                        |            | Adjustment |                                  | Specifications/<br>Remarks |
|------------------------|--|------------------------------------|------------|------------|----------------------------------|----------------------------|
|                        |  | Test equipment                     | Terminal   | Parts      | Method                           |                            |
| 1. Setting             | 1) Power supply voltage<br>DC Power supply terminal: 13.6V   |                                    |            |            |                                  |                            |
| 2. VCO lock voltage    | 1) CH: TX high   | Digital voltmeter                  | CV         | TC2        | 5.5V                             | ±0.1V                      |
|                        | 2) CH: RX high   |                                    |            | TC1        | 5.5V                             | ±0.1V                      |
|                        | 3) CH: TX low  |                                    |            |            | Check                            |                            |
|                        | 4) CH: RX low  |                                    |            |            |                                  | 0.8V or more               |
| 3. IF Coil             | 1) CH: RX center wide<br>2) SSG output: -53dBm(501uV)<br>Mod: 1kHz, Dev: 3kHz  | SSG<br>Digital voltmeter           | AFV        | L22        | 3.2~3.3V(DC)                     |                            |
| 4. RF Band-pass filter | 1) CH: RX center wide<br>CH: RX low wide<br>CH: RX high wide<br>2) Tra generator output: -30dBm<br>Connect the spectrum analyzer to BPF terminal | Tra generator<br>Spectrum analyzer | ANT<br>BPF | TC3<br>TC5 | Adjust the BPF waveform to Fig.1 |                            |

### Receiver Section

| Item           | Condition   | Measurement   |                | Adjustment |                             | Specifications/<br>Remarks |
|----------------|---|---|----------------|------------|-----------------------------|----------------------------|
|                |   | Test equipment                                      | Terminal       | Parts      | Method                      |                            |
| 1. Sensitivity | 1) CH: RX low: Wide/Narrow<br>CH: RX center: Wide/Narrow<br>CH: RX high: Wide/Narrow<br>2) SSG output:<br>-118dBm(0.28μV): Wide<br>-116dBm(0.35μV): Narrow<br>Mod: 1kHz<br>Dev: ±3.0kHz: Wide<br>Dev: ±1.5kHz: Narrow | SSG<br>Oscilloscope<br>AF. V. M<br>Distortion meter | ANT<br>Ext. SP |            | Check                       | SINAD:<br>12dB or higher   |
| 2. Squelch 9   | 1) CH: RX low: Wide<br>CH: RX center: Wide/Narrow<br>CH: RX high: Wide<br>2) SSG output:<br>9dB above to 12dB SINAD level:<br>Wide/Narrow<br>Mod: 1kHz<br>Dev: ±3.0kHz: Wide<br>Dev: ±1.5kHz: Narrow                  |   |                | PC key     | Adjust to open the squelch. |                            |
| 3. Squelch 1   | 1) CH: RX low: Wide<br>CH: RX center: Wide/Narrow<br>CH: RX high: Wide<br>2) SSG output:<br>2dB above to 12dB SINAD level:<br>Wide/Narrow<br>Mod: 1kHz<br>Dev: ±3.0kHz: Wide<br>Dev: ±1.5kHz: Narrow                  |   |                |            |                             |                            |

### Test frequency(MHz)

#### TK-8108

| Channel   | TX      | RX      |
|-----------|---------|---------|
| 1: Center | 470.100 | 470.050 |
| 2: Low    | 450.100 | 450.050 |
| 3: High   | 489.900 | 489.950 |
| 4         | 470.000 | 470.000 |
| 5         | 470.200 | 470.200 |
| 6         | 470.400 | 470.400 |

## ADJUSTMENT

## Transmitter section

| Item               | Condition   | Measurement  |            | Adjustment |   | Specifications/<br>Remarks   |
|--------------------|---|--|------------|------------|---|--|
|                    |   | Test equipment   | Terminal   | Parts      | Method  |  |
| 1. Frequency       | 1) CH: TX center<br>2) Transmit   | Frequency counter  | ANT        | PC key     | Adjust to center frequency  | within $\pm 100\text{Hz}$  |
| 2. High power      | 1) CH: TX low<br>CH: TX low'<br>CH: TX center<br>CH: TX high'<br>CH: TX high<br>2) Transmit               | Power meter  |            |            | 25W   | $\pm 1.0\text{W}$  |
| 3. Low Power       | 1) CH: TX low<br>CH: TX low'<br>CH: TX center<br>CH: TX high'<br>CH: TX high<br>2) Transmit               |  |            |            | 5W  | $\pm 0.5\text{W}$  |
| 4. DQT balance     | 1) CH: TX low: Wide<br>CH: TX center: Wide/Narrow<br>CH: TX high: Wide<br>2) Transmit                     |  |            |            | Modulation analyzer or linear detector(LPF: 3kHz)<br>Oscilloscope                         |  |
| 5. Max deviation   | 1) CH: TX low: Wide<br>CH: TX center: Wide/Narrow<br>CH: TX high: Wide<br>2) AG: 1kHz/50mV<br>3) Transmit | Modulation analyzer or linear detector(LPF: 15kHz)<br>Oscilloscope<br>AG | ANT<br>MIC |            | $\pm 4.0\text{kHz}$ : Wide<br>$\pm 2.0\text{kHz}$ : Narrow<br>According to the large +, - | $\pm 50\text{Hz}$  |
| 6. Mic sensitivity | 1) CH: TX center: Wide/Narrow<br>2) AG: 1kHz/5mV<br>3) Transmit   | AF.V.M   |            |            | Check   | $\pm 3\text{kHz} \pm 0.2\text{kHz}$ : Wide<br>$\pm 1.5\text{kHz} \pm 0.1\text{kHz}$ : Narrow |
| 7. QT deviation    | 1) CH: TX low: Wide<br>CH: TX center: Wide/Narrow<br>CH: TX high: Wide<br>2) Transmit                     | Modulation analyzer or linear detector(LPF: 3kHz)<br>Oscilloscope        |            |            | $\pm 0.75\text{kHz}$ : Wide<br>$\pm 0.35\text{kHz}$ : Narrow                              | $\pm 0.05\text{kHz}$   |
| 8. QT deviation    | 1) CH: TX low: Wide<br>CH: TX center: Wide/Narrow<br>CH: TX high: Wide<br>2) Transmit                     |  |            |            | $\pm 0.75\text{kHz}$ : Wide<br>$\pm 0.35\text{kHz}$ : Narrow                              | $\pm 0.05\text{kHz}$   |
| 9. DTMF deviation  | 1) CH: TX center: Wide/Narrow<br>2) Transmit  |  |            |            | $\pm 3.0\text{kHz}$ : Wide<br>$\pm 1.5\text{kHz}$ : Narrow                                | $\pm 0.2\text{kHz}$  |

## Test frequency(MHz)

## TK-8108

| Channel   | TX      | RX      |
|-----------|---------|---------|
| 1: Center | 470.100 | 470.050 |
| 2: Low    | 450.100 | 450.050 |
| 3: High   | 489.900 | 489.950 |
| 4         | 470.000 | 470.000 |
| 5         | 470.200 | 470.200 |
| 6         | 470.400 | 470.400 |

## ADJUSTMENT

### BPF-Wave

- TK-8108

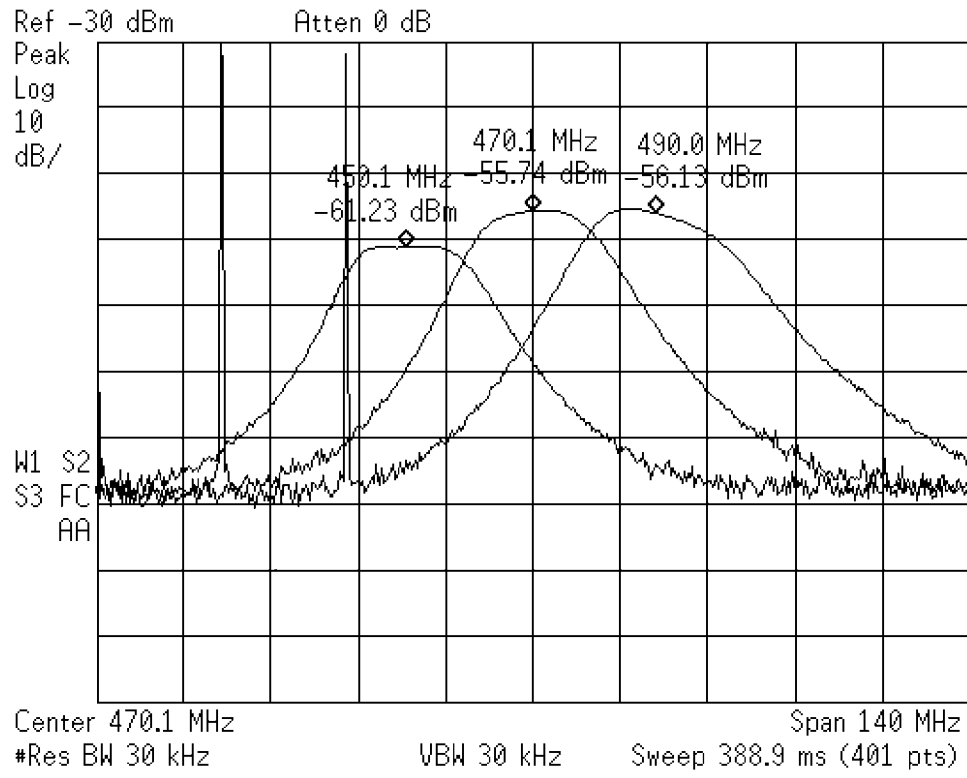
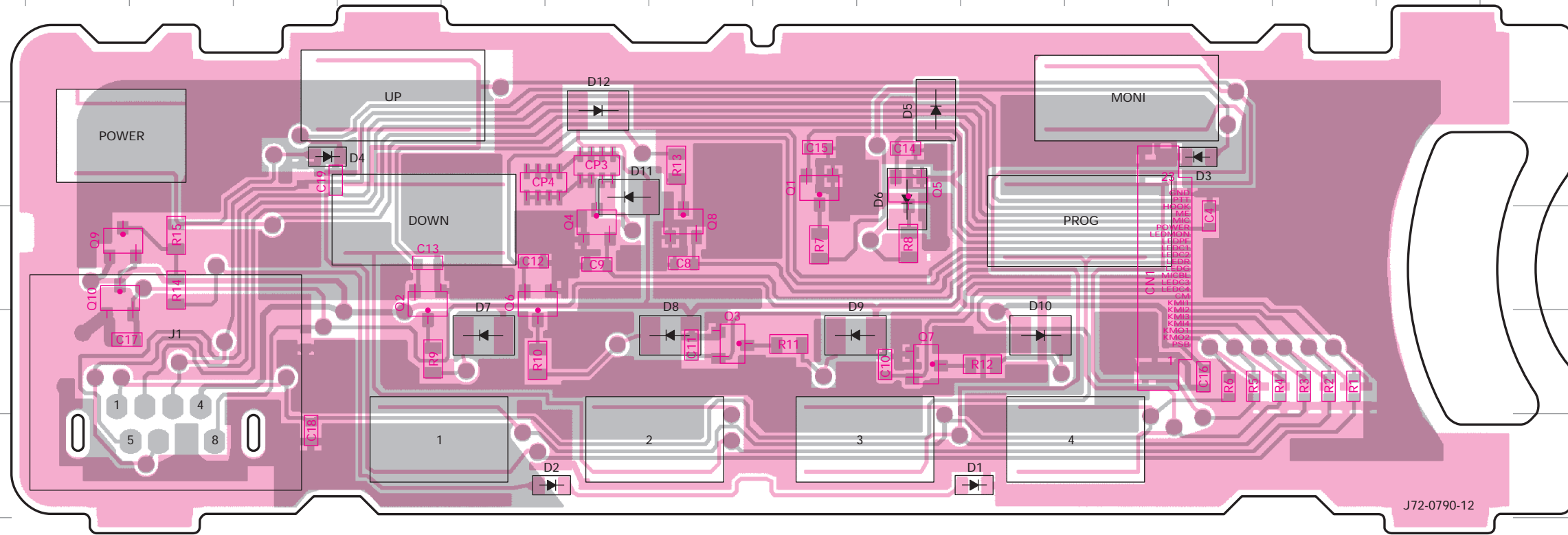

Fig. 1

# PC BOARD TK-8108

DISPLAY UNIT (X54-3340-20) Component side view + Foil side view (J72-0790-12)



DISPLAY UNIT (X57-3340-20)  
Component side view

| Ref. No. | Address |
|----------|---------|
| Q1       | 4J      |
| Q2       | 5F      |
| Q3       | 6I      |
| Q4       | 5H      |
| Q5       | 4K      |
| Q6       | 5G      |
| Q7       | 6K      |
| Q8       | 5I      |
| Q9       | 5C      |
| Q10      | 5C      |
| D1       | 7L      |
| D2       | 7H      |
| D3       | 4N      |
| D4       | 4E      |
| D5       | 4K      |
| D6       | 4K      |
| D7       | 6G      |
| D8       | 6I      |
| D9       | 6J      |
| D10      | 6L      |
| D11      | 4H      |
| D12      | 4H      |

Component side  
Foil side

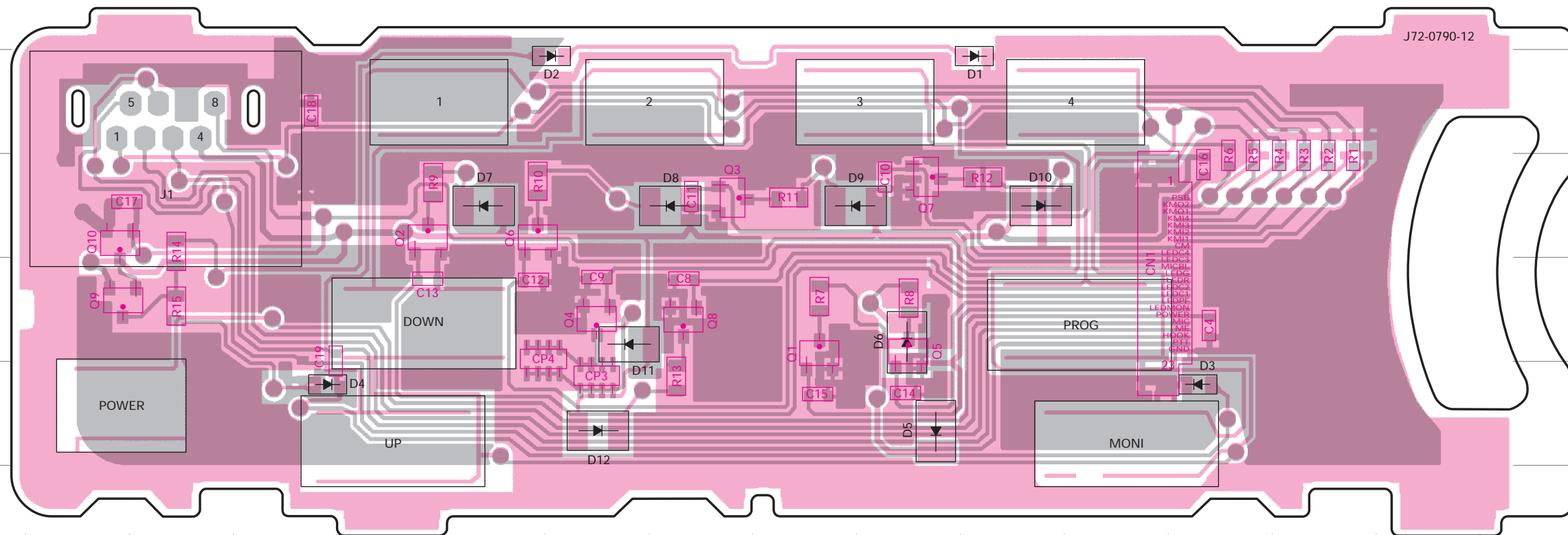

DISPLAY UNIT (X54-3340-20)  
Foil side view

| Ref. No. | Address |
|----------|---------|
| Q1       | 11J     |
| Q2       | 10F     |
| Q3       | 10I     |
| Q4       | 11H     |
| Q5       | 11K     |
| Q6       | 10G     |
| Q7       | 10K     |
| Q8       | 11I     |
| Q9       | 11C     |
| Q10      | 10C     |
| D1       | 9L      |
| D2       | 9H      |
| D3       | 12N     |
| D4       | 12E     |
| D5       | 12K     |
| D6       | 11K     |
| D7       | 10G     |
| D8       | 10I     |
| D9       | 10J     |
| D10      | 10L     |
| D11      | 11H     |
| D12      | 12H     |

Component side  
Foil side



# TK-8108 PC BOARD

## TX-RX UNIT (X57-6303-01) Component side view (J72-0789-02)

TX-RX UNIT (X57-6303-01)  
Component side view

| Ref. No. | Address |
|----------|---------|
| IC1      | 10K     |
| IC3      | 8O      |
| IC4      | 10R     |
| IC9      | 7G      |
| IC12     | 6R      |
| IC17     | 10D     |
| IC19     | 7F      |
| IC21     | 8Q      |
| IC22     | 8Q      |
| IC101    | 5L      |
| IC102    | 8D      |
| Q2       | 9J      |
| Q4       | 10J     |
| Q5       | 10J     |
| Q6       | 11M     |
| Q16      | 8H      |
| Q19      | 10O     |
| Q22      | 9H      |
| Q27      | 5F      |
| Q30      | 10E     |
| Q32      | 8E      |
| Q33      | 10D     |
| Q34      | 5E      |
| Q35      | 7E      |
| Q38      | 7F      |
| Q41      | 8P      |
| Q42      | 4G      |
| Q43      | 9H      |
| Q101     | 5D      |
| D1       | 11G     |
| D2       | 10G     |
| D3       | 10H     |
| D4       | 9E      |
| D6       | 9K      |
| D7       | 10J     |
| D13      | 9P      |
| D15      | 9P      |
| D27      | 5F      |
| D34      | 6P      |
| D39      | 6E      |
| D41      | 4F      |
| D43      | 8P      |
| D44      | 8P      |

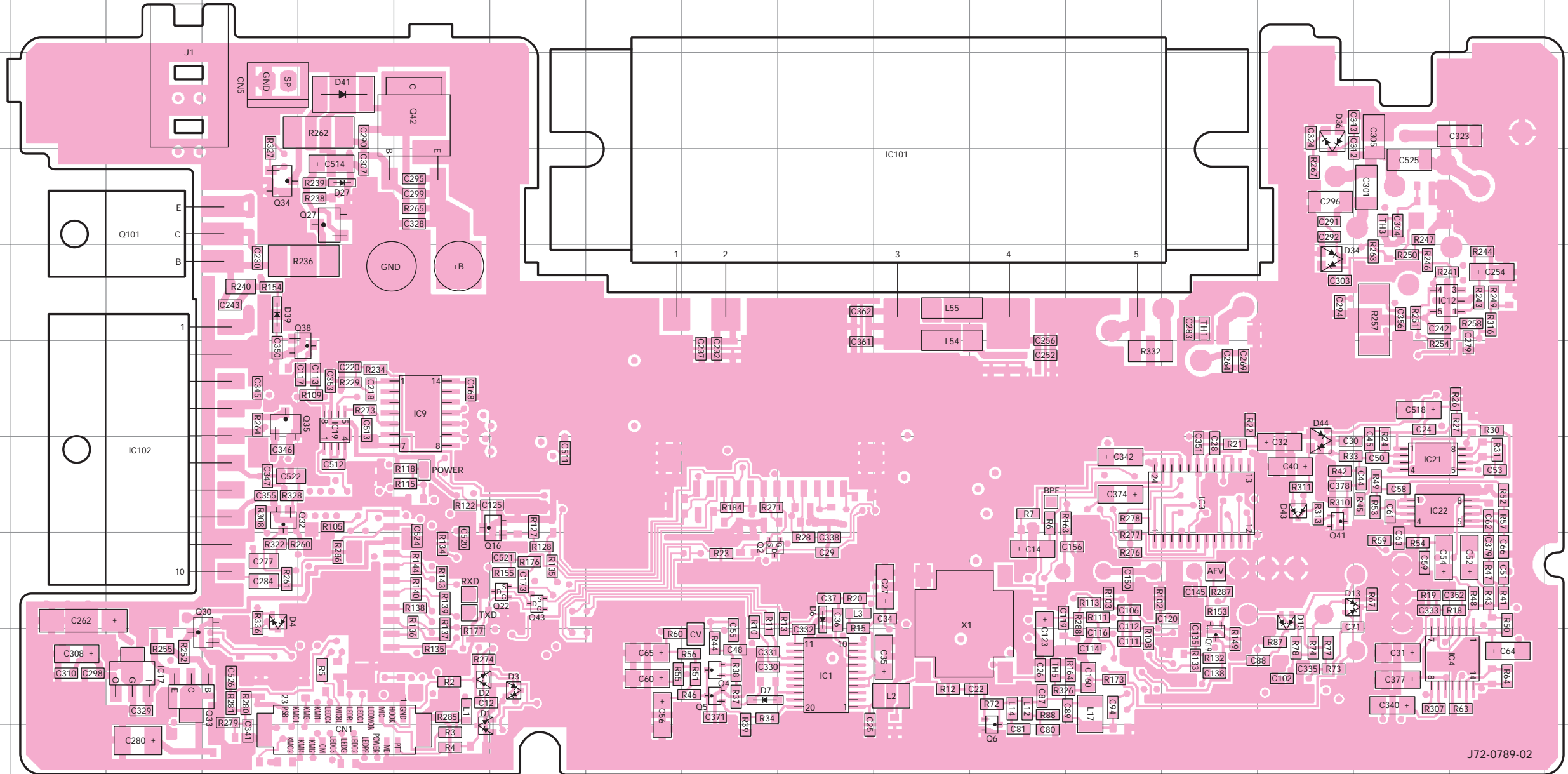

Component side

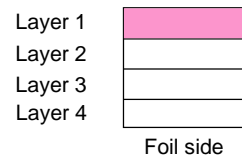

LA4600

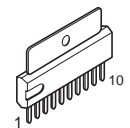

NJM2902V

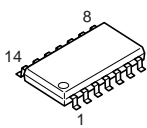

24LC08BT-1SN

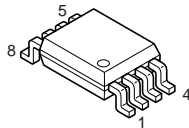

784214AGC119  
784214AGC125

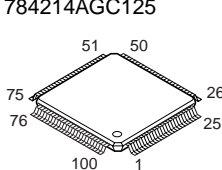

KRX102U

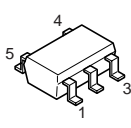

3SK255

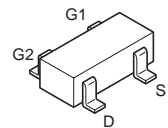

KRC404RTK  
KRC414RTK

- 2SA1745
- 2SA1832
- 2SC2412K
- 2SC4617
- 2SC4738
- 2SC5108



2SC3357  
2SC2954

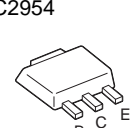

2SA1641

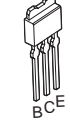

KTA1664

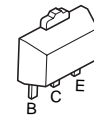

DTC363EU

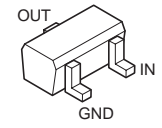

# PC BOARD TK-8108

TX-RX UNIT (X57-6303-01) Foil side view (J72-0789-02)

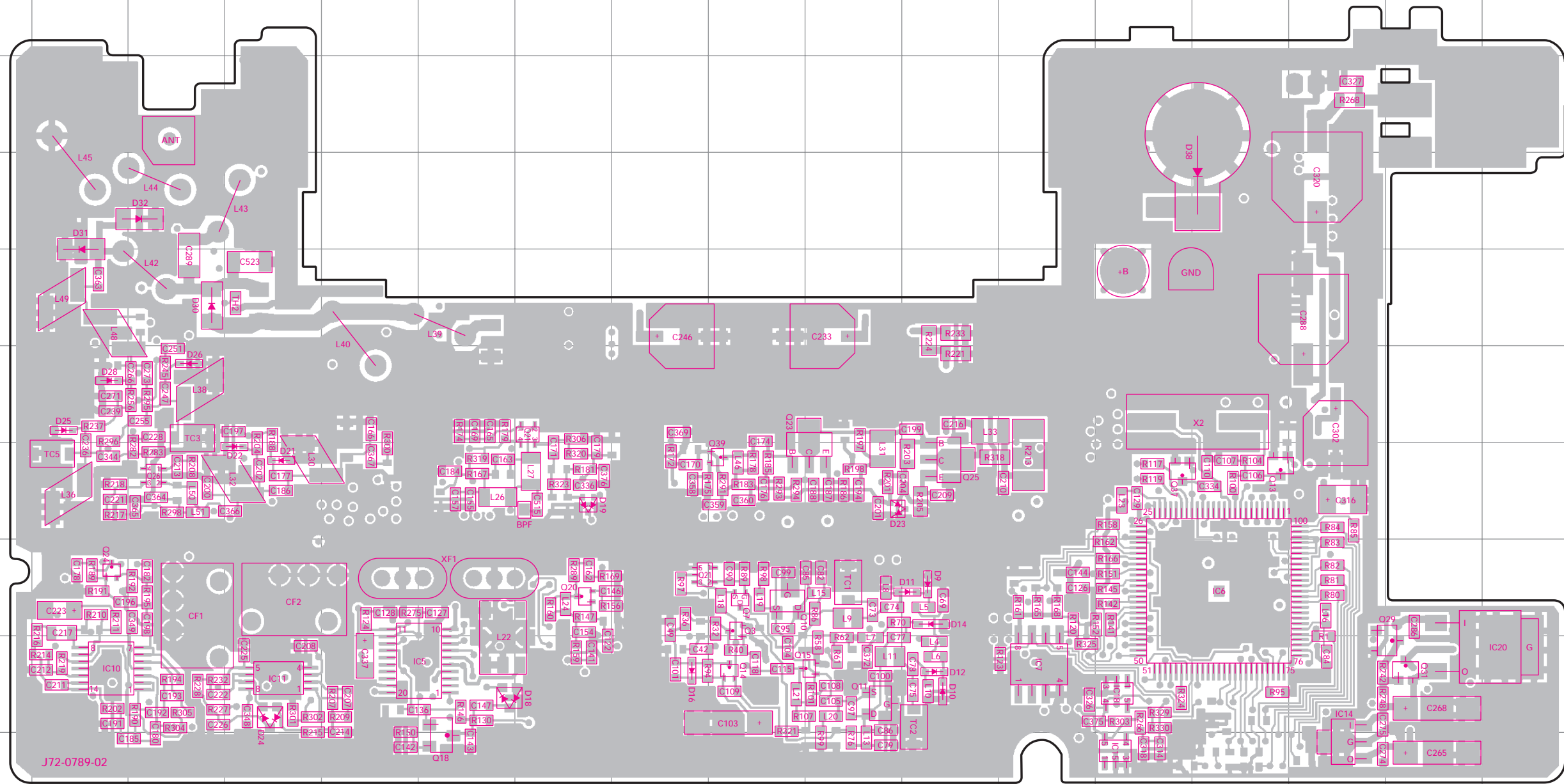

TX-RX UNIT (X57-6303-01)

Foil side view

| Ref. No. | Address |
|----------|---------|
| IC5      | 10F     |
| IC6      | 9N      |
| IC7      | 10L     |
| IC10     | 10B     |
| IC11     | 10D     |
| IC14     | 10O     |
| IC15     | 11M     |
| IC18     | 10M     |
| IC20     | 10Q     |
| IC23     | 10G     |
| Q3       | 9I      |
| Q7       | 9I      |
| Q10      | 9I      |
| Q11      | 10J     |
| Q12      | 9H      |
| Q13      | 8N      |
| Q14      | 10I     |
| Q15      | 10J     |
| Q18      | 11F     |
| Q20      | 9G      |
| Q21      | 7G      |
| Q23      | 8J      |
| Q24      | 9B      |
| Q25      | 8K      |
| Q26      | 8C      |
| Q29      | 10P     |
| Q31      | 10P     |
| Q37      | 8M      |
| Q39      | 8I      |
| D9       | 9K      |
| D10      | 10K     |
| D11      | 9K      |
| D12      | 10K     |
| D14      | 9K      |
| D16      | 10H     |
| D18      | 10F     |
| D19      | 8G      |
| D21      | 8D      |
| D22      | 8D      |
| D23      | 8J      |
| D24      | 10D     |
| D25      | 7B      |
| D26      | 7C      |
| D28      | 7B      |
| D30      | 6C      |
| D31      | 5B      |
| D32      | 5C      |
| D38      | 5N      |

KRA225S  
KRC102S

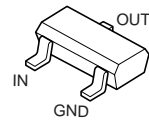

2SC4649  
2SC4919

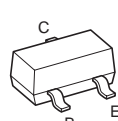

TC7W74FU

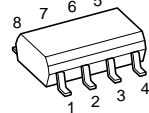

KTA1046

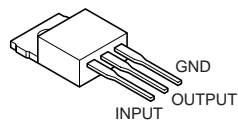

DA221



MA742

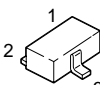

2SK508NV



2SJ243  
2SK1824

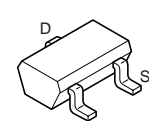

M62363FP

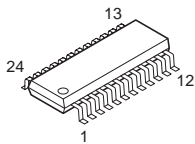

M67741L-35

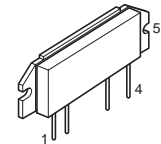

M67741H-32

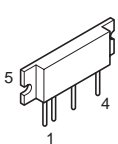

Component side

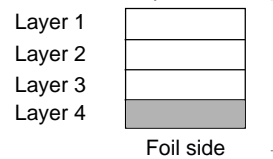

Foil side

# TK-8108 PC BOARD

## TX-RX UNIT (X57-6303-01) Component side view + Foil side view (J72-0789-02)

TX-RX UNIT (X57-6303-01)  
Component side + Foil side view

| Ref. No. | Address |
|----------|---------|
| IC1      | 10K     |
| IC3      | 8O      |
| IC4      | 10R     |
| IC5      | 10N     |
| IC6      | 9F      |
| IC7      | 10H     |
| IC9      | 7G      |
| IC10     | 10R     |
| IC11     | 10P     |
| IC12     | 6R      |
| IC14     | 11E     |
| IC15     | 11G     |
| IC17     | 10D     |
| IC18     | 10G     |
| IC19     | 7F      |
| IC20     | 10C     |
| IC21     | 8Q      |
| IC22     | 8Q      |
| IC27     | 9L      |
| IC101    | 5L      |
| IC102    | 8D      |
| Q2       | 9J      |
| Q3       | 9K      |
| Q4       | 10J     |
| Q5       | 10J     |
| Q6       | 11M     |
| Q7       | 9K      |
| Q10      | 9J      |
| Q11      | 10J     |
| Q12      | 9L      |
| Q13      | 8F      |
| Q14      | 10K     |
| Q15      | 10J     |
| Q16      | 8H      |
| Q18      | 11N     |
| Q19      | 10O     |
| Q20      | 9M      |
| Q21      | 7M      |
| Q22      | 9H      |
| Q23      | 8J      |
| Q24      | 9R      |
| Q25      | 8I      |
| Q26      | 8Q      |
| Q27      | 5F      |
| Q29      | 10D     |
| Q30      | 10E     |
| Q31      | 10D     |
| Q32      | 8E      |
| Q33      | 10E     |
| Q34      | 5E      |
| Q35      | 7E      |
| Q37      | 8G      |
| Q38      | 7F      |
| Q39      | 8K      |
| Q41      | 8P      |
| Q42      | 4G      |
| Q43      | 9H      |
| Q101     | 5D      |
| D1       | 11G     |
| D2       | 10G     |
| D3       | 10H     |
| D4       | 9E      |
| D6       | 9K      |
| D7       | 10J     |
| D9       | 9I      |
| D10      | 10I     |

| Ref. No. | Address |
|----------|---------|
| D11      | 9I      |
| D12      | 10I     |
| D13      | 9P      |
| D14      | 9I      |
| D15      | 9P      |
| D16      | 10L     |
| D18      | 10M     |
| D19      | 8M      |
| D21      | 8P      |
| D22      | 8P      |
| D23      | 8J      |
| D24      | 10P     |
| D25      | 7R      |
| D26      | 7Q      |

| Ref. No. | Address |
|----------|---------|
| D27      | 5F      |
| D28      | 7R      |
| D30      | 6Q      |
| D31      | 5R      |
| D32      | 5Q      |
| D34      | 6P      |
| D36      | 4P      |
| D38      | 5G      |
| D39      | 6E      |
| D41      | 4F      |
| D43      | 8P      |
| D44      | 8P      |

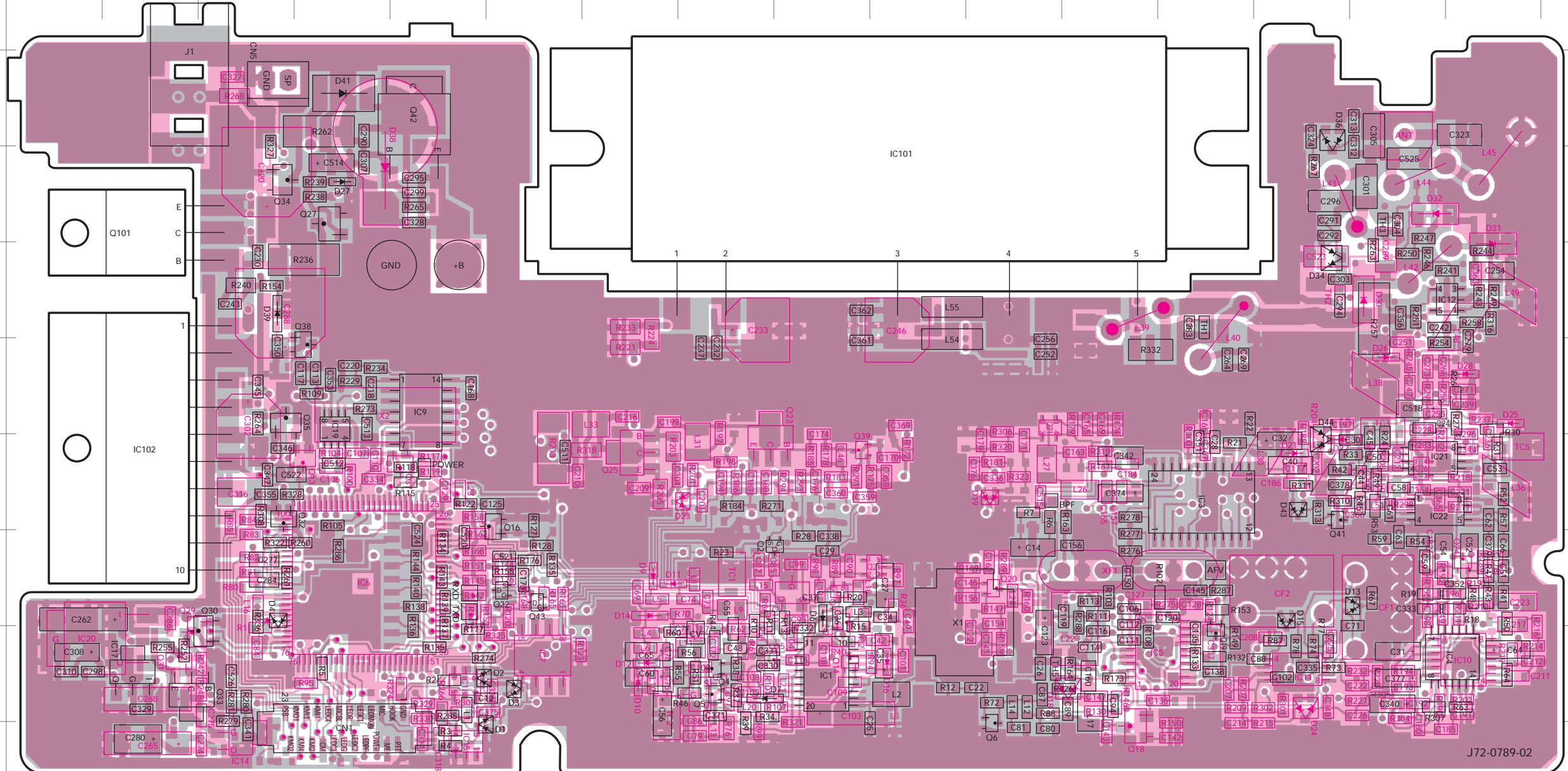

PST9140NR

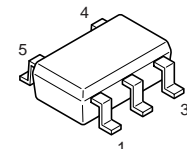

MB15A02

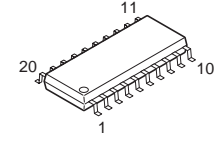

NJM78L05UA

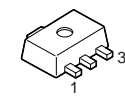

NJM2100V  
NJM2904V  
UPB1509GV

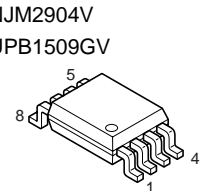

TA75SO1F

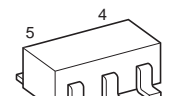

LC73872M

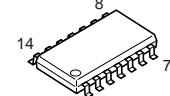

KIA7808AF

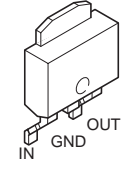

TA14489V

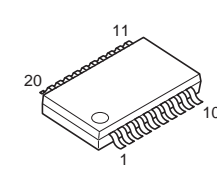

● Connect 1 and 4.

Component side

Layer 1

Layer 2

Layer 3

Layer 4

Foil side

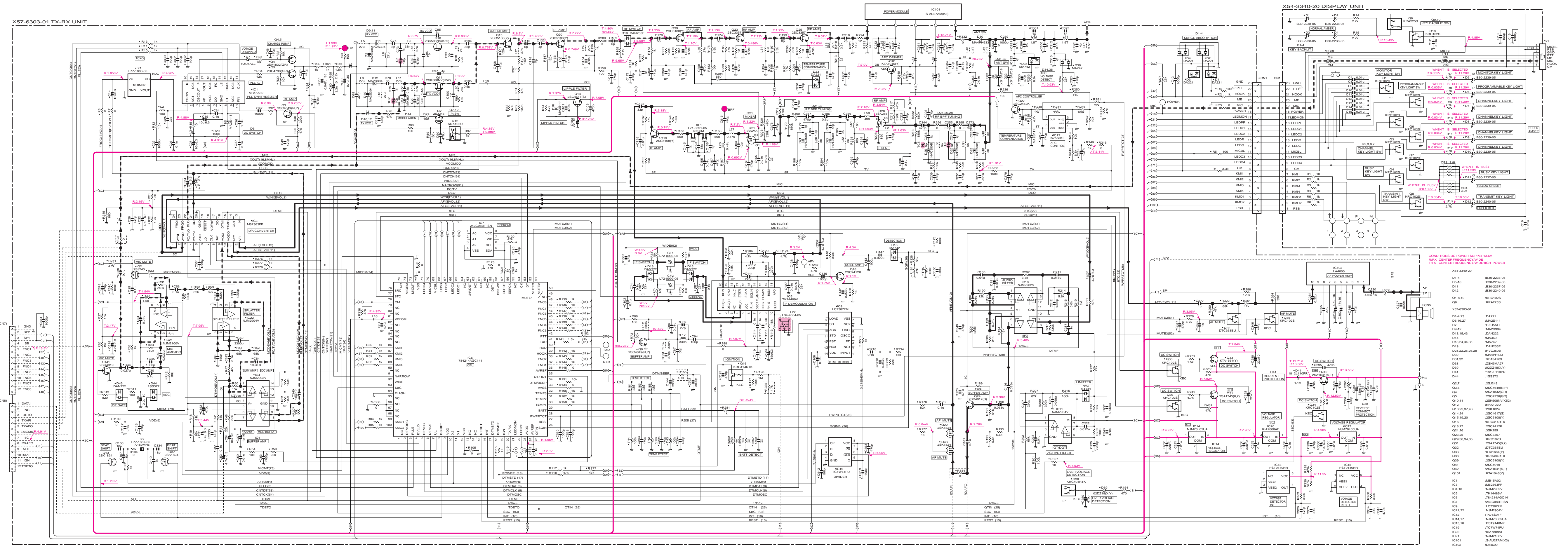

Note : Components marked with a dot (●) are parts of layer1.

# TK-8108 TK-8108 BLOCK DIAGRAM

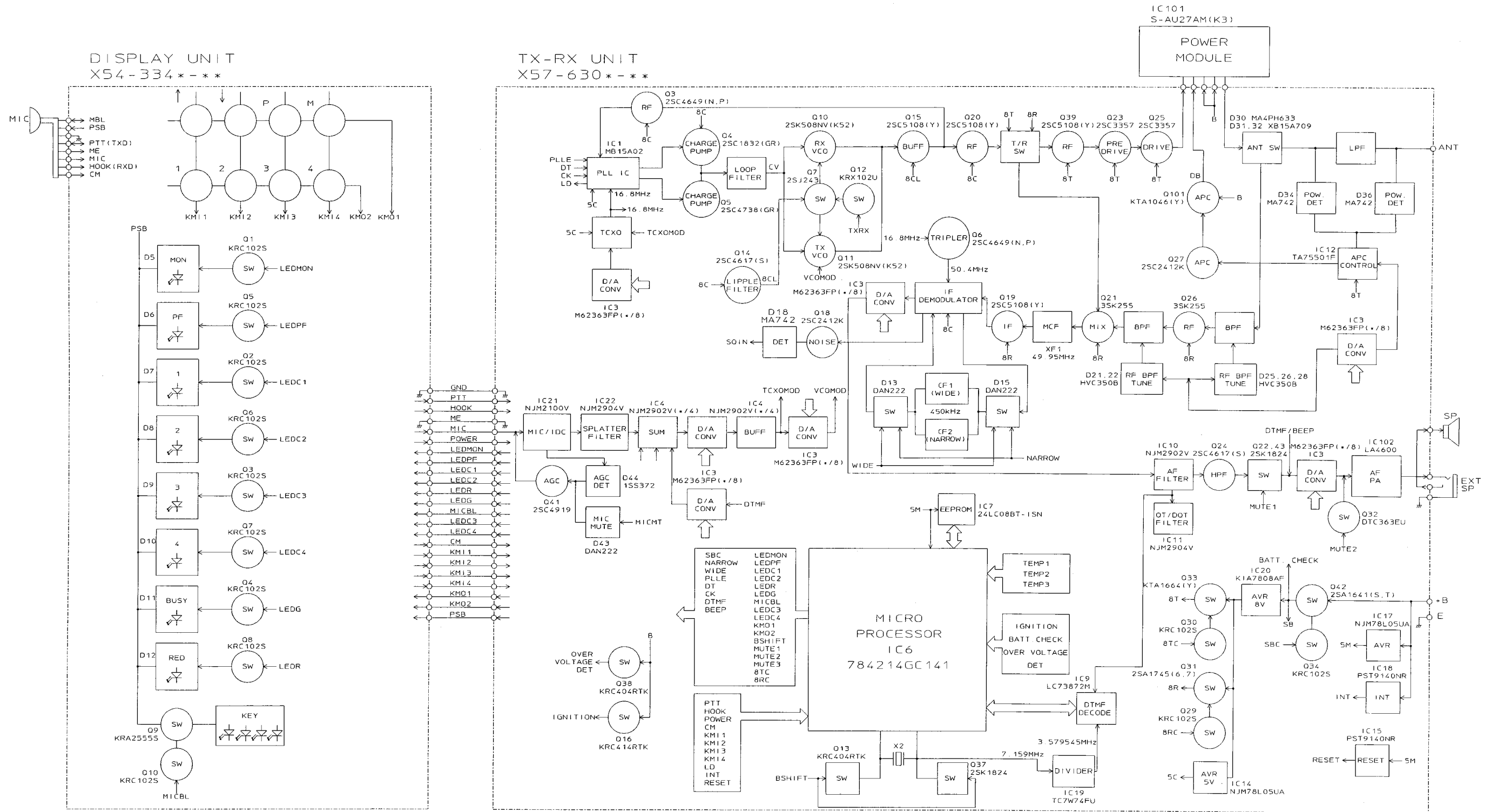

# TK-8108 TK-8108 LEVEL DIAGRAM

## RX section

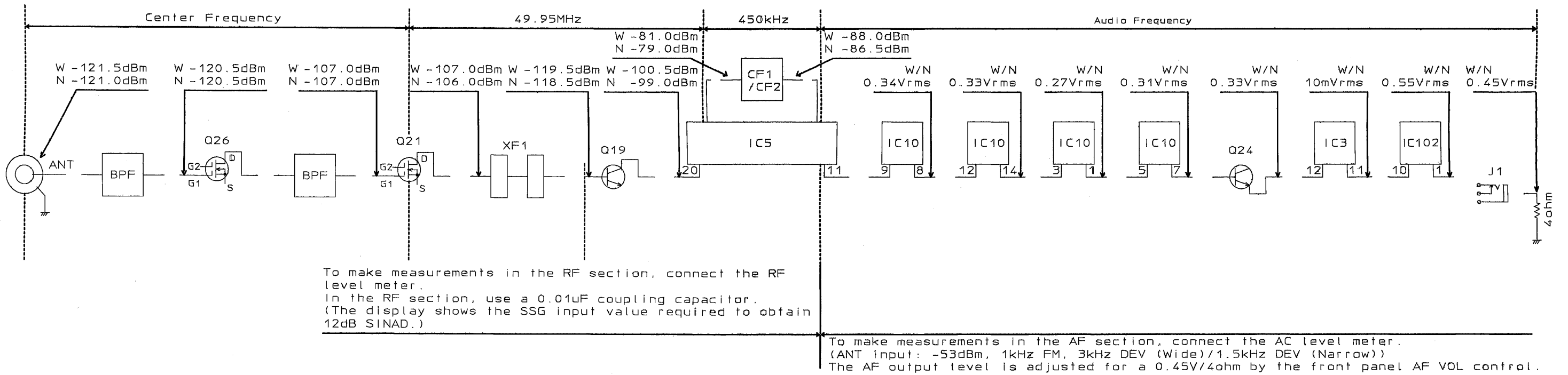

## TX section

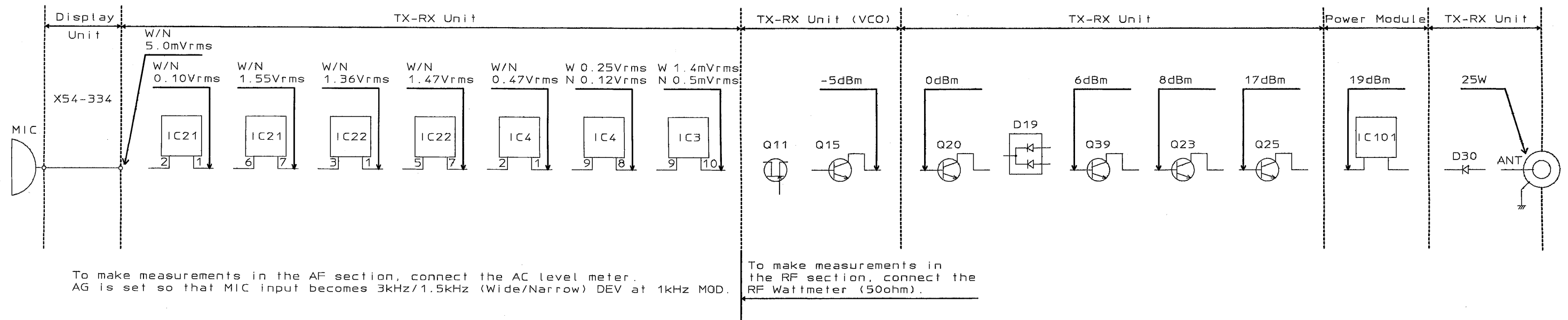

## TERMINAL FUNCTION

### CN1 (TX-RX Unit)

| Pin No. | Name    | Function                   |
|---------|---------|----------------------------|
| 1       | GND     | Ground                     |
| 2       | PTT     | PTT/TXD                    |
| 3       | HOOK    | Hook detection/RXD         |
| 4       | ME      | Mic ground                 |
| 5       | MIC     | Mic signal input           |
| 6       | POWER   | Power switch               |
| 7       | LED MON | Signal of MON Key control  |
| 8       | LED PF  | Signal of PF Key control   |
| 9       | LED C1  | Signal of channel1 control |
| 10      | LED C2  | Signal of channel2 control |
| 11      | LED R   | Signal of TX control       |
| 12      | LED G   | Signal of Busy control     |
| 13      | MICBL   | Mic backlight control      |
| 14      | LED C3  | Signal of channel3 control |
| 15      | LED C4  | Signal of channel4 control |
| 16      | CM      | Mic data detection         |
| 17      | KM11    | Key matrix input 11        |
| 18      | KM12    | Key matrix input 22        |
| 19      | KM13    | Key matrix input 33        |
| 20      | KM14    | Key matrix input 44        |
| 21      | KM01    | Key matrix input 01        |
| 22      | KM02    | Key matrix input 02        |
| 23      | PSB     | Switched B                 |

### J1 (TX-RX Unit)

| Pin No. | Name | Function  |
|---------|------|---|
| 1       | SP   | Audio signal output to internal/external speaker. |
| 2       | E    | Ground  |

### J1 (Display Unit)

| Pin No. | Name     | Function               |
|---------|----------|------------------------|
| 1       | MBL      | MIC backlight control. |
| 2       | PSB      | 13.6V.                 |
| 3       | GND      | Ground.                |
| 4       | PTT/TXD  | PTT.                   |
| 5       | ME       | MIC ground.            |
| 6       | MIC      | MIC signal input.      |
| 7       | HOOK/RXD | Hook detection         |
| 8       | CM       | MIC data detection.    |

# TK-8108

## SPECIFICATIONS

### GENERAL

|                                   |  |
|-----------------------------------|--|
| Frequency Range .....             | 450 to 490MHz  |
| Number of Channels .....          | 8 channels   |
| Channel Spacing .....             | Wide : 25kHz<br>Narrow : 12.5kHz   |
| PLL Channel Stepping .....        | 5, 6.25kHz   |
| Operating Voltage .....           | 13.6V DC $\pm$ 15%   |
| Current Drain .....               | Less than 0.4A on standby<br>Less than 1.0A on receive<br>Less than 8.0A on transmit |
| Operating Temperature Range ..... | -30°C to +60°C   |
| Dimensions & Weight .....         | 160 (W) x 43 (H) x 107 (D) mm,<br>Approx 1.0kg                                       |
| Channel Frequency Spread .....    | 40MHz  |

### RECEIVER

(Measurements made per EIA standard EIA/TIA-603)

|                                |  |
|--------------------------------|--|
| Sensitivity (12dB SINAD) ..... | Wide : 0.28 $\mu$ V<br>Narrow : 0.35 $\mu$ V |
| Selectivity .....              | Wide : 75dB<br>Narrow : 65dB                 |
| Intermodulation .....          | Wide : 70dB<br>Narrow : 60dB                 |
| Spurious Response .....        | 75dB   |
| Audio Power Output .....       | 4.0W   |
| Frequency Stability .....      | $\pm$ 2.5ppm                                 |

### TRANSMITTER

(Measurements made per EIA standard EIA/TIA-603)

|                              |                                    |
|------------------------------|------------------------------------|
| RF Power Output .....        | 25W                                |
| Spurious and Harmonics ..... | 70dB                               |
| Modulation .....             | Wide : 16K0F3E<br>Narrow : 11K0F3E |
| FM Noise .....               | Wide : 45dB<br>Narrow : 40dB       |
| Audio Distortion .....       | Less than 3%                       |
| Frequency Stability .....    | $\pm$ 2.5ppm                       |

## KENWOOD CORPORATION

2967-3, Ishikawa-machi, Hachioji-shi, Tokyo 192-8525, Japan

### KENWOOD SERVICE CORPORATION

P.O. BOX 22745, 2201 East Dominguez Street, Long Beach, CA 90801-5745, U.S.A.

### KENWOOD ELECTRONICS CANADA INC.

6070 Kestrel Road, Mississauga, Ontario, Canada L5T 1S8

### KENWOOD ELECTRONICS DEUTSCHLAND GMBH

Rembrücker Str. 15, 63150 Heusenstamm, Germany

### KENWOOD ELECTRONICS BELGIUM N.V.

Leuvensesteenweg 248 J, 1800 Vilvoorde, Belgium

### KENWOOD ELECTRONICS FRANCE S.A.

13, Boulevard Ney, 75018 Paris, France

### KENWOOD ELECTRONICS U.K. LIMITED

KENWOOD House, Dwight Road, Watford, Herts., WD1 8EB United Kingdom

### KENWOOD ELECTRONICS EUROPE B.V.

Amsterdamseweg 37, 1422 AC Uithoorn, The Netherlands

### KENWOOD ELECTRONICS ITALIA S.p.A.

Via G. Sirtori, 7/9 20129 Milano, Italy

### KENWOOD IBERICA S.A.

Bolivia, 239-08020 Barcelona, Spain

### KENWOOD ELECTRONICS AUSTRALIA PTY. LTD.

(A.C.N. 001 499 074)

16 Giffnock Avenue, Centrecourt Estate, North Ryde, N.S.W. 2113, Australia

### KENWOOD ELECTRONICS (HONG KONG) LTD.

Unit 3712-3724, Level 37, Tower one Metroplaza, 223 Hing Fong Road, Kwai Fong, N.T., Hong Kong

### KENWOOD ELECTRONICS TECHNOLOGIES(S) PTE LTD.

Sales Marketing Division

1 Ang Mo Kio Street 63, Singapore 569110

