

KENWOOD

Document Copyrights

Copyright 2006 by Kenwood Corporation. All rights reserved.

No part of this manual may be reproduced, translated, distributed, or transmitted in any form or by any means, electronic, mechanical, photocopying, recording, or otherwise, for any purpose without the prior written permission of Kenwood.

Disclaimer

While every precaution has been taken in the preparation of this manual, Kenwood assumes no responsibility for errors or omissions. Neither is any liability assumed for damages resulting from the use of the information contained herein. Kenwood reserves the right to make changes to any products herein at any time for improvement purposes.

This TK-7102H service manual contains a number of sections which differ from the service manual (B51-8610-00) for the TK-7102H. For items other than those in this TK-7102H service manual please refer to the service manual (B51-8610-00) for the TK-7102H.

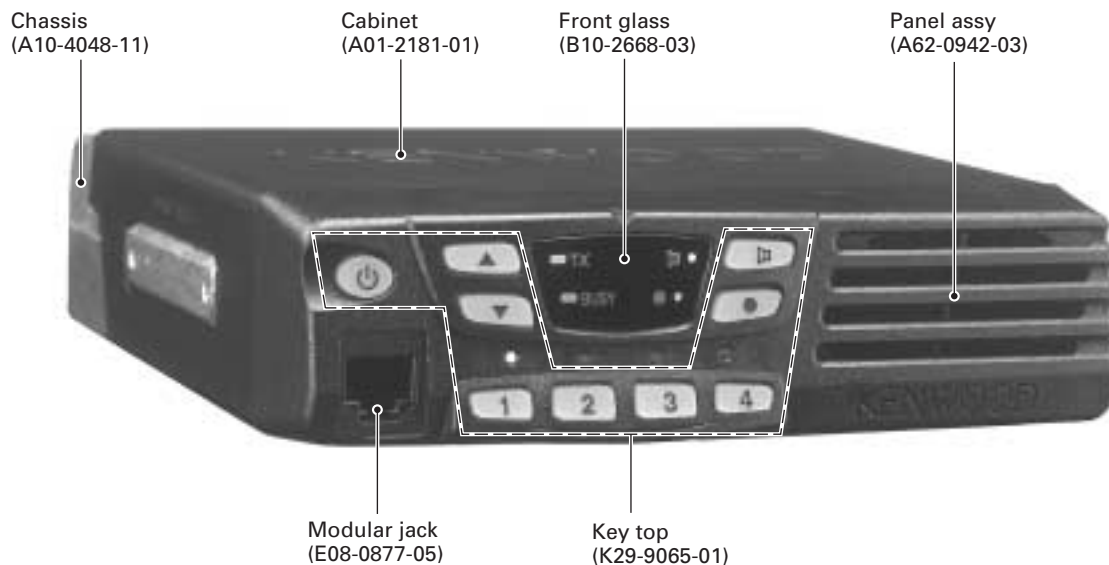

CONTENTS

GENERAL	2	TX-RX UNIT (X57-6380-XX)	19
PARTS LIST	4	SCHEMATIC DIAGRAM	25
EXPLODED VIEW	11	BLOCK DIAGRAM	29
ADJUSTMENT	12	LEVEL DIAGRAM	31
PC BOARD VIEWS		SPECIFICATIONS	33
DISPLAY UNIT (X54-3340-20)	17		

GENERAL

INTRODUCTION

SCOPE OF THIS MANUAL

This manual is intended for use by experienced technicians familiar with similar types of commercial grade communications equipment. It contains all required service information for the equipment and is current as of this publication date. Changes which may occur after publication are covered by either Service Bulletins or Manual Revisions, which are issued as required.

ORDERING REPLACEMENT PARTS

When ordering replacement parts or equipment information, the full part identification number should be included. This applies to all parts : components, kits, and chassis. If the part number is not known, include the chassis or kit number of which it is a part and a sufficient description of the required component for proper identification.

PERSONNEL SAFETY

The following precautions are recommended for personnel safety :

- DO NOT transmit if someone is within two feet (0.6 meter) of the antenna.
- DO NOT transmit until all RF connectors are secure and any open connectors are properly terminated.
- SHUT OFF this equipment when near electrical blasting caps or while in an explosive atmosphere.
- All equipment should be properly grounded before power-up for safe operation.
- This equipment should be serviced by only qualified technicians.

PRE-INSTALLATION CONSIDERATIONS

1. UNPACKING

Unpack the radio from its shipping container and check for accessory items. If any item is missing, please contact KENWOOD immediately.

2. LICENSING REQUIREMENTS

Federal regulations require a station license for each radio installation (mobile or base) be obtained by the equipment owner. The licensee is responsible for ensuring transmitter power, frequency, and deviation are within the limits permitted by the station license.

Transmitter adjustments may be performed only by a licensed technician holding an FCC first, second or general class commercial radiotelephone operator's license. There is no license required to install or operate the radio.

3. PRE-INSTALLATION CHECKOUT

3-1. Introduction

Each radio is adjusted and tested before shipment. However, it is recommended that receiver and transmitter operation be checked for proper operation before installation.

3-2. Testing

The radio should be tested complete with all cabling and accessories as they will be connected in the final installation. Transmitter frequency, deviation, and power output should be checked, as should receiver sensitivity, squelch operation, and audio output. Signalling equipment operation should be verified.

GENERAL

4. PLANNING THE INSTALLATION

4-1. General

Inspect the vehicle and determine how and where the radio antenna and accessories will be mounted.

Plan cable runs for protection against pinching or crushing wiring, and radio installation to prevent overheating.

4-2. Antenna

The favored location for an antenna is in the center of a large, flat conductive area, usually at the roof center. The trunk lid is preferred, bond the trunk lid and vehicle chassis using ground straps to ensure the lid is at chassis ground.

4-3. Radio

The universal mount bracket allows the radio to be mounted in a variety of ways. Be sure the mounting surface is adequate to support the radio's weight. Allow sufficient space around the radio for air cooling. Position the radio close enough to the vehicle operator to permit easy access to the controls when driving.

4-4. DC Power and wiring

1. This radio may be installed in negative ground electrical systems only. Reverse polarity will cause the cable fuse to blow. Check the vehicle ground polarity before installation to prevent wasted time and effort.
2. Connect the positive power lead directly to the vehicle battery positive terminal. Connecting the Positive lead to any other positive voltage source in the vehicle is not recommended.
3. Connect the ground lead directly to the battery negative terminal.
4. The cable provided with the radio is sufficient to handle the maximum radio current demand. If the cable must be extended, be sure the additional wire is sufficient for the current to be carried and length of the added lead.

5. INSTALLATION PLANNING – CONTROL STATIONS

5-1. Antenna system

Control station. The antenna system selection depends on many factors and is beyond the scope of this manual. Your KENWOOD dealer can help you select an antenna system that will best serve your particular needs.

5-2. Radio location

Select a convenient location for your control station radio which is as close as practical to the antenna cable entry point. Secondly, use your system's power supply (which supplies the voltage and current required for your system). Make sure sufficient air can flow around the radio and power supply to allow adequate cooling.

SERVICE

This radio is designed for easy servicing. Refer to the schematic diagrams, printed circuit board views, and alignment procedures contained in this manual.

NOTE

If you do not intend to use the 3.5-mm jack for the external speaker, fit the supplied speaker-jack cap to stop dust and sand getting in.

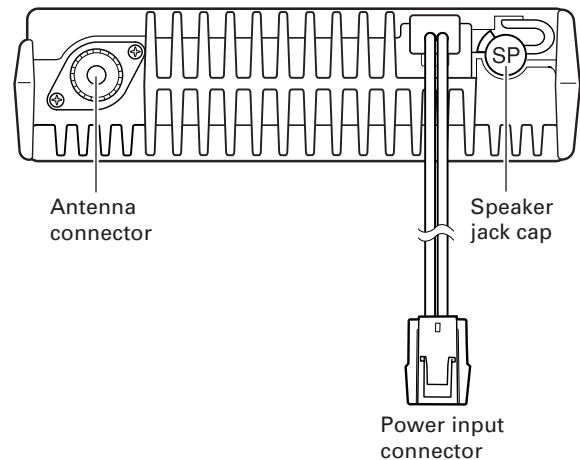

TK-7102H

PARTS LIST

* New Parts. Δ indicates safety critical components.

Parts without **Parts No.** are not supplied.

Les articles non mentionnés dans le **Parts No.** ne sont pas fournis.

Teile ohne **Parts No.** werden nicht geliefert.

L : Scandinavia

Y : PX (Far East, Hawaii)

Y : AAFES (Europe)

K : USA

T : England

X : Australia

P : Canada

E : Europe

M : Other Areas

TK-7102H (Y51-4810-XX)

DISPLAY UNIT (X54-3340-20), TX-RX UNIT (X57-6380-XX)

Ref. No.	Address	New parts	Parts No.	Description	Destination
TK-7102H					
1	1B		A01-2181-01	CABINET	
2	3B	*	A10-4048-11	CHASSIS	
3	3A		A62-0942-03	PANEL ASSY	
5	3A		B10-2668-03	FRONT GLASS	
-	-		B62-1596-00	INSTRUCTION MANUAL (ENGLISH)	
-	-		B62-1597-00	INSTRUCTION MANUAL (SPANISH)	
8	3B		B72-2036-04	MODEL NAME PLATE	K
8	3B		B72-2037-04	MODEL NAME PLATE	K2
8	3B		B72-2038-04	MODEL NAME PLATE	M
8	3B		B72-2039-04	MODEL NAME PLATE	M2
13	3B		E04-0167-05	RF COAXIAL RECEPTACLE (M)	
-	-		E30-3339-05	DC CORD ACCESSORY	
15	2B		E30-3448-05	DC CORD (RADIO)	
16	2A		E37-0961-05	FLAT CABLE	
17	3A		E37-0962-05	SPEAKER CABLE	
20	3B	*	F01-1024-24	HEAT CONDUCTOR CUBE (DRIVE FET)	
21	2B		F10-2421-01	SHIELDING COVER (UPPER)	
22	3C		F51-0017-05	FUSE (6*30) ACCESSORY	
-	-		G10-1274-04	FIBROUS SHEET (PANEL ASSY)	
26	2B,3B	*	G11-4127-14	RUBBER SHEET	
27	3B		G13-1468-04	CUSHION (DC CORD)	
28	3A		G13-1836-04	CUSHION (SPEAKER)	
29	3B		G53-1525-03	PACKING (PANEL)	
30	2B		G53-1542-03	PACKING (PHONE JACK)	
31	1B		G53-1544-01	PACKING (CABINET)	
32	2A		G53-1548-02	GASKET	K2,M2
-	-		H12-3112-05	PACKING FIXTURE	
-	-		H13-1190-02	CARTON BOARD	
-	-		H25-2341-04	PROTECTION BAG	
-	-		H52-1829-12	ITEM CARTON CASE	
-	-		J19-1584-05	MIC HOLDER ACCESSORY	K,K2
-	-		J29-0662-03	BRACKET ACCESSORY	
42	3A		K29-9065-01	KEY TOP	
A	2B		N67-2608-46	PAN HEAD SEMS SCREW	
B	2B,3B		N87-2606-46	BRAZIER HEAD TAPTITE SCREW	
C	1B,2B		N87-2614-46	BRAZIER HEAD TAPTITE SCREW	
-	-		N99-0395-05	SCREW SET ACCESSORY	
46	3A		T07-0739-05	SPEAKER	
-	-		T91-0624-05	MICROPHONE ACCESSORY	K,K2
DISPLAY UNIT (X54-3340-20)					
D1-4			B30-2238-05	LED (Y)	
D5-10			B30-2239-05	LED (SY)	
D11			B30-2237-05	LED (YG)	
D12			B30-2240-05	LED (SR)	
C4			CK73GB1H103K	CHIP C 0.010UF K	
C8-17			CK73GB1H103K	CHIP C 0.010UF K	
C18			CC73GCH1H101J	CHIP C 100PF J	
C19			CK73GB1H102K	CHIP C 1000PF K	

Ref. No.	Address	New parts	Parts No.	Description	Destination
CN1			E40-6170-05	FLAT CABLE CONNECTOR	
J1			E08-0877-05	MODULAR JACK	
CP3,4			RK75GB1J392J	CHIP-COM 3.9K J 1/16W	
R1-6			RK73GB1J102J	CHIP R 1.0K J 1/16W	
R7-15			RK73FB2A272J	CHIP R 2.7K J 1/10W	
Q1-8			KRC102S	DIGITAL TRANSISTOR	
Q9			KRA225S	DIGITAL TRANSISTOR	
Q10			KRC102S	DIGITAL TRANSISTOR	
TX-RX UNIT (X57-6380-XX) -20 : K,M -21 : K2,M2					
C12			CK73GB1H102K	CHIP C 1000PF K	
C14			C92-0560-05	CHIP-TAN 10UF 6.3WW	
C22			CK73GB1H102K	CHIP C 1000PF K	
C24			CK73GB1H103K	CHIP C 0.010UF K	
C25			CC73GCH1H220J	CHIP C 22PF J	
C26			CK73GB1C104K	CHIP C 0.10UF K	
C27			C92-0560-05	CHIP-TAN 10UF 6.3WW	
C28			CK73GB1H102K	CHIP C 1000PF K	
C29,30			CK73GB1C104K	CHIP C 0.10UF K	
C31,32			C92-0507-05	CHIP-TAN 4.7UF 6.3WW	
C34			CK73GB1C104K	CHIP C 0.10UF K	
C35			C92-0560-05	CHIP-TAN 10UF 6.3WW	
C36			CK73GB1H103K	CHIP C 0.010UF K	
C37			CK73GB1C104K	CHIP C 0.10UF K	
C40			C92-0514-05	CHIP-TAN 2.2UF 10WW	
C42			CK73GB1H102K	CHIP C 1000PF K	
C44			CK73GB1C273K	CHIP C 0.027UF K	
C45			CK73GB1H102K	CHIP C 1000PF K	
C48			CK73GB1H102K	CHIP C 1000PF K	
C49			CK73GB1H471K	CHIP C 470PF K	
C50			CK73GB1C223K	CHIP C 0.022UF K	
C51			CK73GB1C104K	CHIP C 0.10UF K	
C52			C92-0507-05	CHIP-TAN 4.7UF 6.3WW	
C53			CK73GB1C104K	CHIP C 0.10UF K	
C54			C92-0560-05	CHIP-TAN 10UF 6.3WW	
C55			CK73GB1H102K	CHIP C 1000PF K	
C56			C92-0555-05	CHIP-TAN 0.047UF 35WW	
C58			CK73GB1H122K	CHIP C 1200PF K	
C59			CK73GB1E103K	CHIP C 0.010UF K	
C60			C92-0004-05	CHIP-TAN 1.0UF 16WW	
C61			CK73GB1H821K	CHIP C 820PF K	
C62			CK73GB1H332K	CHIP C 3300PF K	
C63			CK73GB1H472K	CHIP C 4700PF K	
C64			C92-0560-05	CHIP-TAN 10UF 6.3WW	
C65			C92-0001-05	CHIP C 0.1UF 35WW	
C66			CC73GCH1H151J	CHIP C 150PF J	
C71			CK73GB1C104K	CHIP C 0.10UF K	
C73			CC73GCH1H040B	CHIP C 4.0PF B	K2,M2
C73			CC73GCH1H080B	CHIP C 8.0PF B	K,M
C74			CC73GCH1H120J	CHIP C 12PF J	K2,M2
C74			CC73GCH1H270J	CHIP C 27PF J	K,M
C75			CC73GCH1H050B	CHIP C 5.0PF B	K2,M2
C75			CC73GCH1H100C	CHIP C 10PF C	K,M

PARTS LIST

TX-RX UNIT (X57-6380-XX)

Ref. No.	Address	New parts	Parts No.	Description	Destination	Ref. No.	Address	New parts	Parts No.	Description	Destination
C77			CC73GCH1H0R5B	CHIP C 0.5PF B		C158			CC73GCH1H220J	CHIP C 22PF J	
C78			CC73GCH1H330J	CHIP C 33PF J	K2,M2	C160			CK73FB1C334K	CHIP C 0.33UF K	
C78,79			CK73GB1H471K	CHIP C 470PF K	K,M	C162			CC73GCH1H101J	CHIP C 100PF J	
C79			CK73GB1H471K	CHIP C 470PF K	K2,M2	C163			CC73GCH1H080B	CHIP C 8.0PF B	
C80			CK73GB1H103K	CHIP C 0.010UF K		C165			CK73GB1H103K	CHIP C 0.010UF K	
C81			CC73GCH1H271J	CHIP C 270PF J		C167			CC73GCH1H100C	CHIP C 10PF C	K,M
C82			CK73GB1H471K	CHIP C 470PF K		C167			CC73GCH1H120J	CHIP C 12PF J	K2,M2
C84			CK73GB1C104K	CHIP C 0.10UF K		C168			CK73GB1H103K	CHIP C 0.010UF K	
C85			CC73GCH1H010B	CHIP C 1.0PF B	K,M	C169-171			CK73GB1H102K	CHIP C 1000PF K	
C85,86			CC73GCH1H020B	CHIP C 2.0PF B	K2,M2	C173			CK73GB1C104K	CHIP C 0.10UF K	
C86			CC73GCH1H020B	CHIP C 2.0PF B	K,M	C174			CC73GCH1H101J	CHIP C 100PF J	
C87			CC73GCH1H560J	CHIP C 56PF J		C176			CK73GB1H102K	CHIP C 1000PF K	
C88			CK73GB1C104K	CHIP C 0.10UF K		C177			CC73GCH1H220J	CHIP C 22PF J	
C90			CK73GB1H471K	CHIP C 470PF K		C178			CK73GB1C104K	CHIP C 0.10UF K	
C94			CC73GCH1H101J	CHIP C 100PF J		C179			CK73GB1H102K	CHIP C 1000PF K	
C95			CC73GCH1H050B	CHIP C 5.0PF B		C180			CK73GB1H103J	CHIP C 0.010UF J	
C97			CC73GCH1H060B	CHIP C 6.0PF B		C182			CK73GB1C104K	CHIP C 0.10UF K	
C99			CC73GCH1H050B	CHIP C 5.0PF B	K2,M2	C184			CK73GB1H102K	CHIP C 1000PF K	
C99,100			CC73GCH1H050B	CHIP C 5.0PF B	K,M	C185			CK73GB1H103J	CHIP C 0.010UF J	
C100			CC73GCH1H060B	CHIP C 6.0PF B	K2,M2	C186			CC73GCH1H020B	CHIP C 2.0PF B	
C101			CK73GB1H471K	CHIP C 470PF K		C187,188			CK73GB1H102K	CHIP C 1000PF K	
C102			CK73GB1C104K	CHIP C 0.10UF K		C191			CK73GB1C473K	CHIP C 0.047UF K	
C103			C92-0568-05	CHIP-TAN 22UF 10WV		C192,193			CK73GB1H103J	CHIP C 0.010UF J	
C104,105			CC73GCH1H0R5B	CHIP C 0.5PF B		C194			CK73GB1H102K	CHIP C 1000PF K	
C106			CC73GCH1H180J	CHIP C 18PF J	K,M	C196			CK73GB1C333K	CHIP C 0.033UF K	
C106			CC73GCH1H220J	CHIP C 22PF J	K2,M2	C197			CK73GB1H102K	CHIP C 1000PF K	
C107			CC73GCH1H060B	CHIP C 6.0PF B		C198			CK73GB1C333K	CHIP C 0.033UF K	
C108,109			CK73GB1H471K	CHIP C 470PF K		C199			CC73GCH1H080B	CHIP C 8.0PF B	
C110			CC73GCH1H060B	CHIP C 6.0PF B		C200,201			CK73GB1H102K	CHIP C 1000PF K	
C111,112			CC73GCH1H331J	CHIP C 330PF J	K,M	C202			CC73GCH1H220J	CHIP C 22PF J	
C111,112			CC73GCH1H391J	CHIP C 390PF J	K2,M2	C206			CC73GCH1H040B	CHIP C 4.0PF B	K,M
C113			CK73GB1H102K	CHIP C 1000PF K		C207			CC73GCH1H221J	CHIP C 220PF J	
C114			CK73GB1C104K	CHIP C 0.10UF K		C208			CK73GB1H103K	CHIP C 0.010UF K	
C115			CC73GCH1H060B	CHIP C 6.0PF B		C209,210			CK73GB1H102K	CHIP C 1000PF K	
C116,117			CK73GB1C104K	CHIP C 0.10UF K		C211			CK73GB1E183K	CHIP C 0.018UF K	
C118			CC73GCH1H030B	CHIP C 3.0PF B		C212			CK73GB1H822K	CHIP C 8200PF K	
C119			CK73GB1H103K	CHIP C 0.010UF K		C213			CK73GB1H102K	CHIP C 1000PF K	
C120			CK73GB1H472K	CHIP C 4700PF K		C214			CK73GB1C683K	CHIP C 0.068UF K	
C121			CC73GCH1H020B	CHIP C 2.0PF B		C216			CC73GCH1H270J	CHIP C 27PF J	
C122			CK73GB1H102K	CHIP C 1000PF K		C217			CK73FB1A105K	CHIP C 1.0UF K	
C123			C92-0662-05	CHIP-TAN 15UF 6.3WV		C218			CK73GB1C104K	CHIP C 0.10UF K	
C125,126			CK73GB1H102K	CHIP C 1000PF K		C220			CK73GB1C473K	CHIP C 0.047UF K	
C127			CK73GB1H103K	CHIP C 0.010UF K		C221			CK73GB1H102K	CHIP C 1000PF K	
C128			CK73GB1H102K	CHIP C 1000PF K		C222			CK73GB1E123K	CHIP C 0.012UF K	
C129			CK73GB1C104K	CHIP C 0.10UF K		C223			C92-0507-05	CHIP-TAN 4.7UF 6.3WV	
C133			CK73GB1H102K	CHIP C 1000PF K		C225			CK73GB1H222K	CHIP C 2200PF K	
C135			CK73GB1H103K	CHIP C 0.010UF K		C226			CK73GB1C683K	CHIP C 0.068UF K	
C136			CK73GB1H102K	CHIP C 1000PF K		C228			CK73GB1H102K	CHIP C 1000PF K	
C138			CC73GCH1H330J	CHIP C 33PF J		C236			CC73GCH1H220J	CHIP C 22PF J	
C141			CC73GCH1H180J	CHIP C 18PF J		C239			CK73GB1H102K	CHIP C 1000PF K	
C142			CK73GB1E223K	CHIP C 0.022UF K		C244			CC73GCH1H010B	CHIP C 1.0PF B	
C143			CK73GB1H102K	CHIP C 1000PF K		C247			CC73GCH1H240J	CHIP C 24PF J	K,M
C144			CK73GB1H392K	CHIP C 3900PF K		C247			CC73GCH1H270J	CHIP C 27PF J	K2,M2
C146			CK73GB1H102K	CHIP C 1000PF K		C251			CK73GB1H102K	CHIP C 1000PF K	
C147			CK73GB1E223K	CHIP C 0.022UF K		C262			C92-0795-05	CHIP-TAN 22UF 10WV	
C150			CC73GCH1H150J	CHIP C 15PF J		C265			C92-0795-05	CHIP-TAN 22UF 10WV	
C152			CC73GCH1H100C	CHIP C 10PF C		C268			C92-0795-05	CHIP-TAN 22UF 10WV	
C154			CK73GB1H102K	CHIP C 1000PF K		C273			CC73GCH1H040B	CHIP C 4.0PF B	K,M
C155			CK73GB1H103K	CHIP C 0.010UF K		C273			CC73GCH1H060B	CHIP C 6.0PF B	K2,M2
C157			CK73GB1H102K	CHIP C 1000PF K		C274			CK73GB1H103K	CHIP C 0.010UF K	

PARTS LIST

TX-RX UNIT (X57-6380-XX)

Ref. No.	Address	New parts	Parts No.	Description	Destination	Ref. No.	Address	New parts	Parts No.	Description	Destination
C275			CK73GB1C104K	CHIP C 0.10UF K		C805			CK73FB1H102K	CHIP C 1000PF K	
C277			CK73FB1A105K	CHIP C 1.0UF K		C807			CK73GB1H102K	CHIP C 1000PF K	
C279			CK73GB1H102K	CHIP C 1000PF K		C808			CK73GB1H681K	CHIP C 680PF K	
C280			C92-0795-05	CHIP-TAN 22UF 10WV		C809			CK73GB1C104K	CHIP C 0.10UF K	
C283			CK73GB1H102K	CHIP C 1000PF K		C811			CK73FB1H102K	CHIP C 1000PF K	
C284			CK73FB1C224K	CHIP C 0.22UF K		C812		*	C93-0571-05	CHIP C 82PF J	K2,M2
C286			CK73GB1C104K	CHIP C 0.10UF K		C812		*	C93-0573-05	CHIP C 120PF J	K,M
C288			C92-0721-05	ELECTRO 330UF 16WV		C815			C92-0719-05	ELECTRO 47UF 25WV	
C290			CK73GB1H102K	CHIP C 1000PF K		C821			CK73FB1H102K	CHIP C 1000PF K	
C295			CK73GB1H102K	CHIP C 1000PF K		C819			C93-0595-05	CHIP C 220PF 500WV	K2
C298,299			CK73GB1H102K	CHIP C 1000PF K		C824			CM73F2H181J	CHIP C 180PF J	
C302			C92-0040-05	CHIP-ELE 47UF 16WV		C827			C93-0603-05	CHIP C 1000PF K	
C304			CK73GB1H102K	CHIP C 1000PF K		C828			CM73F2H680J	CHIP C 68PF J	K,M
C307			CK73GB1H102K	CHIP C 1000PF K		C828			CM73F2H820J	CHIP C 82PF J	K2,M2
C308			C92-0560-05	CHIP-TAN 10UF 6.3WV		C829			CK73FB1C474K	CHIP C 0.47UF K	
C310			CK73GB1H103K	CHIP C 0.010UF K		C831			C93-0560-05	CHIP C 10PF D	K,M
C314			CK73GB1C104K	CHIP C 0.10UF K		C831			C93-0564-05	CHIP C 22PF J	K2,M2
C316			C92-0516-05	CHIP-TAN 4.7UF 16WV		C832			C93-0603-05	CHIP C 1000PF K	
C318			CK73GB1H102K	CHIP C 1000PF K		C833			C93-0553-05	CHIP C 3.0PF C	K2,M2
C320			C92-0722-05	ELECTRO 470UF 16WV		C833			C93-0562-05	CHIP C 15PF J	K,M
C326-328			CK73GB1H102K	CHIP C 1000PF K		C834			CK73GB1H103K	CHIP C 0.010UF K	
C329			CK73GB1H103K	CHIP C 0.010UF K		C835			C93-0603-05	CHIP C 1000PF K	
C330-332			CC73GCH1H101J	CHIP C 100PF J		C836			CK73GB1H103K	CHIP C 0.010UF K	
C333			CK73GB1H102K	CHIP C 1000PF K		C837			CC73GCH1H120J	CHIP C 12PF J	K,M
C334			CC73GCH1H180J	CHIP C 18PF J	K,M	C837			CC73GCH1H180J	CHIP C 18PF J	K2,M2
C334			CC73GCH1H220J	CHIP C 22PF J	K2,M2	C838			C93-0603-05	CHIP C 1000PF K	
C335,336			CK73GB1C104K	CHIP C 0.10UF K		C839			C93-0565-05	CHIP C 27PF J	K,M
C337			C92-0507-05	CHIP-TAN 4.7UF 6.3WV		C839			C93-0566-05	CHIP C 33PF J	K2,M2
C338			CK73GB1C104K	CHIP C 0.10UF K		C840			CC73GCH1H0R5B	CHIP C 0.5PF B	
C340			C92-0560-05	CHIP-TAN 10UF 6.3WV		C841			CC73GCH1H020B	CHIP C 2.0PF B	
C341			CK73GB1H102K	CHIP C 1000PF K		C843			C93-0566-05	CHIP C 33PF J	
C342			C92-0507-05	CHIP-TAN 4.7UF 6.3WV		C844			CK73GB1H102K	CHIP C 1000PF K	
C344-353			CK73GB1H102K	CHIP C 1000PF K		C846			CC73GCH1H0R5B	CHIP C 0.5PF B	
C355			CK73GB1C104K	CHIP C 0.10UF K		C847			CC73GCH1H020B	CHIP C 2.0PF B	
C358			CK73GB1H102K	CHIP C 1000PF K		C849			C93-0566-05	CHIP C 33PF J	
C365,366			CK73GB1H102K	CHIP C 1000PF K		C850			CK73GB1H102K	CHIP C 1000PF K	
C367			CC73GCH1H101J	CHIP C 100PF J	K,M	C852			C93-0564-05	CHIP C 22PF J	
C367			CC73GCH1H151J	CHIP C 150PF J	K2,M2	C853			CK73FB1C474K	CHIP C 0.47UF K	
C371,372			CK73GB1H471K	CHIP C 470PF K		C854			CC73GCH1H030B	CHIP C 3.0PF B	
C374			C92-0507-05	CHIP-TAN 4.7UF 6.3WV		C855,856			C93-0555-05	CHIP C 5.0PF C	
C375			CK73GB1C104K	CHIP C 0.10UF K		TC1-3			C05-0245-05	CERAMIC TRIMMER CAP (10PF)	
C376			CK73GB1H102K	CHIP C 1000PF K		TC5			C05-0399-05	CERAMIC TRIMMER CAP (6PF)	
C377			C92-0004-05	CHIP-TAN 1.0UF 16WV		CN1			E40-5651-05	FLAT CABLE CONNECTOR	
C378			CK73GB1H102K	CHIP C 1000PF K		CN5			E40-3246-05	PIN ASSY	
C379			CK73GB1C104K	CHIP C 0.10UF K		CN800			E23-0486-05	TERMINAL	
C508			CK73GB1H102K	CHIP C 1000PF K		J1			E11-0425-05	3.5D PHONE JACK (3P)	
C511			CK73GB1H102K	CHIP C 1000PF K		CF1			L72-0993-05	CERAMIC FILTER	
C512,513			CC73GCH1H101J	CHIP C 100PF J		CF2			L72-0999-05	CERAMIC FILTER	
C514			CC73GCH1H150J	CHIP C 15PF J		L1			L92-0140-05	FERRITE CHIP	
C515			CC73GCH1H0R5B	CHIP C 0.5PF B	K2,M2	L2			L41-1005-08	SMALL FIXED INDUCTOR	
C515			CC73GCH1H040B	CHIP C 4.0PF B	K,M	L3			L92-0138-05	FERRITE CHIP	
C518			C92-0507-05	CHIP-TAN 4.7UF 6.3WV		L4			L92-0140-05	FERRITE CHIP	
C523			CK73GB1H102K	CHIP C 1000PF K		L5,6			L40-2702-86	SMALL FIXED INDUCTOR (27UH)	K,M
C524			CK73GB1H392K	CHIP C 3900PF K		L5,6			L40-2785-92	SMALL FIXED INDUCTOR (270NH)	K2,M2
C525			CK73FB1A105K	CHIP C 1.0UF K		L7			L92-0140-05	FERRITE CHIP	
C526,527			CK73GB1H102K	CHIP C 1000PF K		L8			L40-2702-86	SMALL FIXED INDUCTOR (27UH)	K,M
C800			CK73GB1H821K	CHIP C 820PF K		L8			L40-2785-92	SMALL FIXED INDUCTOR (270NH)	K2,M2
C802			CC73GCH1H330J	CHIP C 33PF J		L9			L40-2778-67	SMALL FIXED INDUCTOR (27NH)	K,M
C803			CC73GCH1H820J	CHIP C 82PF J		L9			L40-3978-67	SMALL FIXED INDUCTOR (39NH)	K2,M2
C804			CK73GB1H102K	CHIP C 1000PF K							

PARTS LIST

TX-RX UNIT (X57-6380-XX)

Ref. No.	Address	New parts	Parts No.	Description	Destination	Ref. No.	Address	New parts	Parts No.	Description	Destination
L10			L40-2702-86	SMALL FIXED INDUCTOR (27UH)	K,M	R19			RK73GB1J683J	CHIP R 68K J 1/16W	
L10			L40-2785-92	SMALL FIXED INDUCTOR (270NH)	K2,M2	R20			RK73GB1J104J	CHIP R 100K J 1/16W	
L11			L40-3978-67	SMALL FIXED INDUCTOR (39NH)	K,M	R21			RK73GB1J152J	CHIP R 1.5K J 1/16W	
L11			L40-6878-67	SMALL FIXED INDUCTOR (68NH)	K2,M2	R22			RK73GB1J122J	CHIP R 1.2K J 1/16W	
L12			L40-3381-86	SMALL FIXED INDUCTOR (0.33UH)		R23			RK73GB1J102J	CHIP R 1.0K J 1/16W	
L13			L40-2291-86	SMALL FIXED INDUCTOR (2.2UH)	K,M	R24			RK73GB1J754J	CHIP R 750K J 1/16W	
L13			L40-2785-92	SMALL FIXED INDUCTOR (270NH)	K2,M2	R26,27			RK73GH1J153D	CHIP R 15K D 1/16W	
L14			L40-3381-86	SMALL FIXED INDUCTOR (0.33UH)		R28			R92-1252-05	CHIP R 0 OHM J 1/16W	
L15			L40-2702-86	SMALL FIXED INDUCTOR (27UH)	K,M	R30			RK73GB1J152J	CHIP R 1.5K J 1/16W	
L15			L40-2785-92	SMALL FIXED INDUCTOR (270NH)	K2,M2	R31			RK73GB1J244J	CHIP R 240K J 1/16W	
L16			L92-0140-05	FERRITE CHIP		R32			R92-1252-05	CHIP R 0 OHM J 1/16W	
L17			L41-3385-08	SMALL FIXED INDUCTOR		R33			RK73GB1J102J	CHIP R 1.0K J 1/16W	
L18			L92-0140-05	FERRITE CHIP		R34			RK73GB1J562J	CHIP R 5.6K J 1/16W	
L19			L40-2702-86	SMALL FIXED INDUCTOR (27UH)	K,M	R36			RK73GB1J471J	CHIP R 470 J 1/16W	
L19			L40-2785-92	SMALL FIXED INDUCTOR (270NH)	K2,M2	R37			RK73GB1J153J	CHIP R 15K J 1/16W	
L20			L40-1085-92	SMALL FIXED INDUCTOR (100NH)	K2,M2	R38			RK73GB1J562J	CHIP R 5.6K J 1/16W	
L20			L40-2291-86	SMALL FIXED INDUCTOR (2.2UH)	K,M	R39			RK73GB1J103J	CHIP R 10K J 1/16W	
L21			L40-6875-92	SMALL FIXED INDUCTOR (68NH)	K2,M2	R40			RK73GB1J224J	CHIP R 220K J 1/16W	
L21			L41-3375-06	SMALL FIXED INDUCTOR	K,M	R41			RK73GB1J273J	CHIP R 27K J 1/16W	
L22			L34-4554-05	COIL		R42			RK73GB1J183J	CHIP R 18K J 1/16W	
L23			L92-0140-05	FERRITE CHIP		R43			RK73GB1J273J	CHIP R 27K J 1/16W	
L24			L41-1585-06	SMALL FIXED INDUCTOR		R44			R92-1252-05	CHIP R 0 OHM J 1/16W	
L25			L41-1085-06	SMALL FIXED INDUCTOR		R45			RK73GB1J334J	CHIP R 330K J 1/16W	
L26			L41-8285-08	SMALL FIXED INDUCTOR		R46			RK73GB1J681J	CHIP R 680 J 1/16W	
L27			L41-5685-08	SMALL FIXED INDUCTOR		R47			RK73GB1J563J	CHIP R 56K J 1/16W	
L30			L34-4612-05	AIR-CORE COIL	K,M	R48			RK73GB1J154J	CHIP R 150K J 1/16W	
L30			L34-4613-05	AIR-CORE COIL	K2,M2	R49			RK73GB1J823J	CHIP R 82K J 1/16W	
L31			L41-6875-08	SMALL FIXED INDUCTOR		R50			RK73GB1J473J	CHIP R 47K J 1/16W	
L32			L34-4612-05	AIR-CORE COIL	K,M	R51			RK73GB1J102J	CHIP R 1.0K J 1/16W	
L32			L34-4613-05	AIR-CORE COIL	K2,M2	R52			RK73GB1J683J	CHIP R 68K J 1/16W	
L33			L41-6875-08	SMALL FIXED INDUCTOR		R53			RK73GB1J823J	CHIP R 82K J 1/16W	
L36			L34-4612-05	AIR-CORE COIL	K,M	R54			RK73GB1J103J	CHIP R 10K J 1/16W	
L36			L34-4613-05	AIR-CORE COIL	K2,M2	R55			RK73GB1J272J	CHIP R 2.7K J 1/16W	
L38			L34-4611-05	AIR-CORE COIL		R56			RK73GB1J152J	CHIP R 1.5K J 1/16W	
L52			L41-5675-06	SMALL FIXED INDUCTOR		R57			RK73GB1J683J	CHIP R 68K J 1/16W	
L54			L41-1085-06	SMALL FIXED INDUCTOR		R58			RK73GB1J473J	CHIP R 47K J 1/16W	
L55			L92-0140-05	FERRITE CHIP		R59			RK73GB1J223J	CHIP R 22K J 1/16W	
L800,801			L41-2775-06	SMALL FIXED INDUCTOR		R60			RK73GB1J103J	CHIP R 10K J 1/16W	
L802			L34-4608-05	AIR-CORE COIL		R61			RK73GB1J473J	CHIP R 47K J 1/16W	
L803			L34-4692-05	AIR-CORE COIL		R62,63			RK73GB1J104J	CHIP R 100K J 1/16W	
L804			L34-4667-05	AIR-CORE COIL		R64			RK73GB1J154J	CHIP R 150K J 1/16W	
L805			L34-4668-05	AIR-CORE COIL		R67			RK73GB1J223J	CHIP R 22K J 1/16W	
L806-808			L34-4670-05	AIR-CORE COIL		R70			RK73GB1J473J	CHIP R 47K J 1/16W	
L809			L34-4667-05	AIR-CORE COIL		R72			RK73GB1J224J	CHIP R 220K J 1/16W	
L810		*	L34-4705-05	AIR-CORE COIL		R73,74			RK73GB1J103J	CHIP R 10K J 1/16W	
L811			L34-4693-05	AIR-CORE COIL		R76			RK73GB1J101J	CHIP R 100 J 1/16W	
X1			L77-1868-15	TCXO (16.8MHZ)		R77,78			RK73GB1J103J	CHIP R 10K J 1/16W	
X2			L77-1867-05	CRYSTAL RESONATOR (7.159MHZ)		R80-85			RK73GB1J102J	CHIP R 1.0K J 1/16W	
X2			L77-1905-05	CRYSTAL RESONATOR (7.159MHZ)		R86			RK73GB1J101J	CHIP R 100 J 1/16W	
XF1			L71-0591-05	MCF (49.95MHZ)		R87			RK73GB1J223J	CHIP R 22K J 1/16W	
R1			RK73GB1J332J	CHIP R 3.3K J 1/16W		R88			RK73GB1J101J	CHIP R 100 J 1/16W	
R2			RK73GB1J102J	CHIP R 1.0K J 1/16W		R89			RK73GB1J104J	CHIP R 100K J 1/16W	
R3			R92-1252-05	CHIP R 0 OHM J 1/16W		R94			RK73GB1J472J	CHIP R 4.7K J 1/16W	
R4,5			RK73GB1J101J	CHIP R 100 J 1/16W		R97			RK73GB1J102J	CHIP R 1.0K J 1/16W	
R6,7			R92-1252-05	CHIP R 0 OHM J 1/16W		R98			RK73GB1J331J	CHIP R 330 J 1/16W	K2,M2
R10,11			RK73GB1J102J	CHIP R 1.0K J 1/16W		R98,99			RK73GB1J221J	CHIP R 220 J 1/16W	K,M
R12			RK73GB1J152J	CHIP R 1.5K J 1/16W		R99			RK73GB1J221J	CHIP R 220 J 1/16W	K2,M2
R13			RK73GB1J102J	CHIP R 1.0K J 1/16W		R100			RK73GB1J102J	CHIP R 1.0K J 1/16W	
R15			RK73GB1J100J	CHIP R 10 J 1/16W		R101			RK73GB1J124J	CHIP R 120K J 1/16W	
R18			RK73GB1J913J	CHIP R 91K J 1/16W		R102			RK73GB1J223J	CHIP R 22K J 1/16W	

PARTS LIST

TX-RX UNIT (X57-6380-XX)

Ref. No.	Address	New parts	Parts No.	Description	Destination	Ref. No.	Address	New parts	Parts No.	Description	Destination
R103			RK73GB1J182J	CHIP R 1.8K J 1/16W	K,M K2,M2	R180			RK73GB1J271J	CHIP R 270 J 1/16W	K2,M2 K,M
R104			R92-1252-05	CHIP R 0 OHM J 1/16W		R181			RK73GB1J102J	CHIP R 1.0K J 1/16W	
R104			RK73GB1J331J	CHIP R 330 J 1/16W		R183			RK73GB1J222J	CHIP R 2.2K J 1/16W	
R106			RK73GB1J472J	CHIP R 4.7K J 1/16W		R184			R92-1252-05	CHIP R 0 OHM J 1/16W	
R107			RK73GB1J101J	CHIP R 100 J 1/16W		R185			RK73GB1J103J	CHIP R 10K J 1/16W	
R108			RK73GB1J274J	CHIP R 270K J 1/16W		R186			RK73GB1J100J	CHIP R 10 J 1/16W	
R109			R92-1252-05	CHIP R 0 OHM J 1/16W		R188			RK73GB1J104J	CHIP R 100K J 1/16W	
R111			RK73GB1J222J	CHIP R 2.2K J 1/16W		R189			RK73GH1J124D	CHIP R 120K D 1/16W	
R113			RK73GB1J183J	CHIP R 18K J 1/16W		R190			RK73GB1J123J	CHIP R 12K J 1/16W	
R114			R92-1252-05	CHIP R 0 OHM J 1/16W		R191			RK73GH1J913D	CHIP R 91K D 1/16W	
R115			RK73GB1J102J	CHIP R 1.0K J 1/16W		R192			RK73GB1J562J	CHIP R 5.6K J 1/16W	
R117			RK73GB1J102J	CHIP R 1.0K J 1/16W		R193			RK73GB1J470J	CHIP R 47 J 1/16W	
R118			RK73GB1J473J	CHIP R 47K J 1/16W		R194			RK73GB1J153J	CHIP R 15K J 1/16W	
R119			RK73GB1J102J	CHIP R 1.0K J 1/16W		R195			RK73GH1J562D	CHIP R 5.6K D 1/16W	
R120			RK73GB1J473J	CHIP R 47K J 1/16W	R196			RK73GB1J471J	CHIP R 470 J 1/16W		
R122,123			RK73GB1J473J	CHIP R 47K J 1/16W	R198			RK73GB1J220J	CHIP R 22 J 1/16W		
R124			RK73GB1J472J	CHIP R 4.7K J 1/16W	R202			RK73GB1J332J	CHIP R 3.3K J 1/16W		
R126			RK73GB1J102J	CHIP R 1.0K J 1/16W	R203			RK73FB2A470J	CHIP R 47 J 1/10W		
R127			RK73GB1J104J	CHIP R 100K J 1/16W	R204			RK73GB1J104J	CHIP R 100K J 1/16W		
R128			RK73GB1J105J	CHIP R 1.0M J 1/16W	R205			RK73FB2A100J	CHIP R 10 J 1/10W		
R130			RK73GB1J332J	CHIP R 3.3K J 1/16W	R206			R92-1252-05	CHIP R 0 OHM J 1/16W		
R132			RK73GB1J471J	CHIP R 470 J 1/16W	R207			RK73GB1J823J	CHIP R 82K J 1/16W		
R133			RK73GB1J101J	CHIP R 100 J 1/16W	R208			RK73GB1J151J	CHIP R 150 J 1/16W		
R134			R92-1252-05	CHIP R 0 OHM J 1/16W	R209			RK73GB1J394J	CHIP R 390K J 1/16W		
R135-140			RK73GB1J102J	CHIP R 1.0K J 1/16W	R210			RK73GB1J334J	CHIP R 330K J 1/16W		
R141			RK73GB1J152J	CHIP R 1.5K J 1/16W	R211			RK73GB1J473J	CHIP R 47K J 1/16W		
R142-144			RK73GB1J102J	CHIP R 1.0K J 1/16W	R213			R92-1217-05	CHIP R 0 OHM		
R145			R92-1252-05	CHIP R 0 OHM J 1/16W	R214			RK73GB1J562J	CHIP R 5.6K J 1/16W		
R146			RK73GB1J334J	CHIP R 330K J 1/16W	R215			RK73GB1J104J	CHIP R 100K J 1/16W		
R147			RK73GB1J473J	CHIP R 47K J 1/16W	R216			RK73GB1J562J	CHIP R 5.6K J 1/16W		
R148			RK73GB1J223J	CHIP R 22K J 1/16W	R217			RK73GB1J474J	CHIP R 470K J 1/16W		
R149			RK73GB1J104J	CHIP R 100K J 1/16W	R218			RK73GB1J124J	CHIP R 120K J 1/16W		
R150			RK73GB1J102J	CHIP R 1.0K J 1/16W	R218			RK73GB1J224J	CHIP R 220K J 1/16W		
R151			RK73GB1J103J	CHIP R 10K J 1/16W	R219			RK73GB1J105J	CHIP R 1.0M J 1/16W		
R152			RK73GB1J473J	CHIP R 47K J 1/16W	R221			RK73FB2A471J	CHIP R 470 J 1/10W		
R153			RK73GB1J331J	CHIP R 330 J 1/16W	R224			RK73FB2A120J	CHIP R 12 J 1/10W		
R154			RK73GB1J471J	CHIP R 470 J 1/16W	R227			RK73GB1J223J	CHIP R 22K J 1/16W		
R155			RK73GB1J472J	CHIP R 4.7K J 1/16W	R228			RK73GB1J184J	CHIP R 180K J 1/16W		
R156			RK73GB1J101J	CHIP R 100 J 1/16W	R229			RK73GB1J223J	CHIP R 22K J 1/16W		
R158			RK73GB1J102J	CHIP R 1.0K J 1/16W	R232			RK73GB1J184J	CHIP R 180K J 1/16W		
R159,160			RK73GB1J101J	CHIP R 100 J 1/16W	R233			RK73FB2A471J	CHIP R 470 J 1/10W		
R161			RK73GB1J473J	CHIP R 47K J 1/16W	R234			RK73GB1J153J	CHIP R 15K J 1/16W		
R162			RK73GB1J102J	CHIP R 1.0K J 1/16W	R237			RK73GB1J104J	CHIP R 100K J 1/16W		
R162,163			RK73GB1J102J	CHIP R 1.0K J 1/16W	R242			RK73GB1J472J	CHIP R 4.7K J 1/16W		
R163			RK73GB1J471J	CHIP R 470 J 1/16W	R245			RK73GB1J104J	CHIP R 100K J 1/16W		
R164			RK73GB1J333J	CHIP R 33K J 1/16W	R248			RK73GB1J473J	CHIP R 47K J 1/16W		
R165			R92-1252-05	CHIP R 0 OHM J 1/16W	R252			RK73GB1J152J	CHIP R 1.5K J 1/16W		
R166			RK73GB1J102J	CHIP R 1.0K J 1/16W	R255			RK73GB1J473J	CHIP R 47K J 1/16W		
R167			RK73GB1J470J	CHIP R 47 J 1/16W	R258			RK73GB1J104J	CHIP R 100K J 1/16W		
R168			RK73GB1J183J	CHIP R 18K J 1/16W	R260			RK73GB1J473J	CHIP R 47K J 1/16W		
R169			RK73GB1J222J	CHIP R 2.2K J 1/16W	R261			RK73GB1J123J	CHIP R 12K J 1/16W		
R172			RK73GB1J102J	CHIP R 1.0K J 1/16W	R262			R92-1215-05	CHIP R 470 J 1/2W		
R173			RK73GB1J104J	CHIP R 100K J 1/16W	R264			RK73GB1J391J	CHIP R 390 J 1/16W		
R174			RK73GB1J470J	CHIP R 47 J 1/16W	R265			RK73GB1J472J	CHIP R 4.7K J 1/16W		
R174			RK73GB1J560J	CHIP R 56 J 1/16W	R266			RK73GB1J334J	CHIP R 330K J 1/16W		
R175			RK73GB1J271J	CHIP R 270 J 1/16W	R268			R92-0670-05	CHIP R 0 OHM		
R176			RK73GB1J823J	CHIP R 82K J 1/16W	R271			RK73GB1J472J	CHIP R 4.7K J 1/16W		
R177			RK73GB1J102J	CHIP R 1.0K J 1/16W	R272,273			RK73GB1J102J	CHIP R 1.0K J 1/16W		
R178			RK73GB1J180J	CHIP R 18 J 1/16W	R274			RK73GB1J223J	CHIP R 22K J 1/16W		
R179			RK73GB1J154J	CHIP R 150K J 1/16W	R275			RK73GB1J333J	CHIP R 33K J 1/16W		

PARTS LIST

TX-RX UNIT (X57-6380-XX)

Ref. No.	Address	New parts	Parts No.	Description	Destination	Ref. No.	Address	New parts	Parts No.	Description	Destination
R276-278			RK73GB1J102J	CHIP R 1.0K J 1/16W		D6			MA2S111	DIODE	
R279			RK73GJ1J393D	CHIP R 39K D 1/16W		D7			HZU5ALL	DIODE	
R280			RK73GH1J274D	CHIP R 270K D 1/16W		D9-12			MA2S304	VARIABLE CAPACITANCE DIODE	
R281			RK73GB1J102J	CHIP R 1.0K J 1/16W		D13			DAN222	DIODE	
R282			RK73GB1J684J	CHIP R 680K J 1/16W		D14			MA360	VARIABLE CAPACITANCE DIODE	
R283			RK73GB1J124J	CHIP R 120K J 1/16W	K2,M2	D15			DAN222	DIODE	
R283			RK73GB1J184J	CHIP R 180K J 1/16W	K,M	D16			MA2S111	DIODE	
R285			RK73GB1J681J	CHIP R 680 J 1/16W		D18			MA742	DIODE	
R286			RK73GB1J124J	CHIP R 120K J 1/16W		D19			DAN235E	DIODE	
R287			RK73GB1J472J	CHIP R 4.7K J 1/16W		D20			1SS355	DIODE	
R288			R92-1252-05	CHIP R 0 OHM J 1/16W		D21,22			HVC350B	VARIABLE CAPACITANCE DIODE	
R301			RK73GB1J104J	CHIP R 100K J 1/16W		D23			DA221	DIODE	
R302			RK73GB1J683J	CHIP R 68K J 1/16W		D24			MA742	DIODE	
R303			RK73GB1J334J	CHIP R 330K J 1/16W		D25,26			HVC350B	VARIABLE CAPACITANCE DIODE	
R304			RK73GB1J224J	CHIP R 220K J 1/16W		D38			ZSH5MA27	SURGE ABSORBER	
R305			RK73GB1J913J	CHIP R 91K J 1/16W		D39			02DZ18(X,Y)	ZENER DIODE	
R306			RK73GB1J224J	CHIP R 220K J 1/16W		D41			1812L110PR	VARIATOR	
R307			RK73GB1J333J	CHIP R 33K J 1/16W		D43			DAN222	DIODE	
R308			R92-1252-05	CHIP R 0 OHM J 1/16W		D44			1SS372	DIODE	
R310			RK73GB1J104J	CHIP R 100K J 1/16W		D800			02DZ5.1(Y)	ZENER DIODE	
R311			RK73GB1J101J	CHIP R 100 J 1/16W		D801			MA4PH633	DIODE	
R313			RK73GB1J821J	CHIP R 820 J 1/16W		D803,804			XB15A709	DIODE	K2,M2
R318			RK73FB2A222J	CHIP R 2.2K J 1/10W		D804			XB15A709	DIODE	K,M
R319,320			RK73GB1J474J	CHIP R 470K J 1/16W		D805,806			MA742	DIODE	
R321			R92-1252-05	CHIP R 0 OHM J 1/16W		D807			1SS355	DIODE	
R322			RK73GB1J683J	CHIP R 68K J 1/16W		IC1			MB15A02	MOS IC	
R323			R92-1252-05	CHIP R 0 OHM J 1/16W		IC3			M62363FP	MOS IC	
R324,325			RK73GB1J102J	CHIP R 1.0K J 1/16W		IC4			NJM2902V	MOS IC	
R326			RK73GB1J152J	CHIP R 1.5K J 1/16W		IC5			TK14489V	BI-POLAR IC	
R328			RK73GB1J100J	CHIP R 10 J 1/16W	K2,M2	IC6		*	784214AGC141	MPU	
R328			R92-1252-05	CHIP R 0 OHM J 1/16W	K,M	IC7			24LC08BT-1SN	ROM IC	
R329			RK73GB1J473J	CHIP R 47K J 1/16W		IC9			LC73872M	MOS IC	
R330			RK73GB1J183J	CHIP R 18K J 1/16W		IC10			NJM2902V	MOS IC	
R331			RK73GB1J102J	CHIP R 1.0K J 1/16W		IC11			NJM2904V	MOS IC	
R332			RK73GB1J474J	CHIP R 470K J 1/16W		IC14			NJM78L05UA	BI-POLAR IC	
R333			RK73GB1J394J	CHIP R 390K J 1/16W		IC15			PST9140NR	MOS IC	
R334,335			RK73GB1J472J	CHIP R 4.7K J 1/16W		IC17			NJM78L05UA	BI-POLAR IC	
R800			RK73GB1J101J	CHIP R 100 J 1/16W		IC18			PST9140NR	MOS IC	
R801			RK73GB1J333J	CHIP R 33K J 1/16W		IC19			TC7W74FU	MOS IC	
R802			RK73GB1J224J	CHIP R 220K J 1/16W		IC20			KIA7808AF	ANALOG IC	
R803			RK73EB2B330J	CHIP R 33 J 1/8W		IC21			NJM2100V	MOS IC	
R804			RK73GB1J333J	CHIP R 33K J 1/16W		IC22			NJM2904V	MOS IC	
R805			RK73EB2B331J	CHIP R 330 J 1/8W		IC23			UPB1509GV	BI-POLAR IC	
R807,808			RK73GB1J471J	CHIP R 470 J 1/16W		IC101	2B		LA4600	BI-POLAR IC	
R809			RK73GB1J102J	CHIP R 1.0K J 1/16W		IC800			TA75W01FU	MOS IC	
R811			R92-1215-05	CHIP R 470 J 1/2W		Q2			2SJ243	FET	
R812,813			RK73GB1J473J	CHIP R 47K J 1/16W		Q3			2SC4649(N,P)	TRANSISTOR	
R814			RK73GB1J563J	CHIP R 56K J 1/16W		Q4			2SA1832(GR)	TRANSISTOR	
R816			R92-1252-05	CHIP R 0 OHM J 1/16W		Q5			2SC4738(GR)	TRANSISTOR	
R817			RK73GB1J473J	CHIP R 47K J 1/16W		Q6			2SC4617(S)	TRANSISTOR	
R818			RK73GB1J221J	CHIP R 220 J 1/16W		Q7			2SJ243	FET	
R819			R92-1252-05	CHIP R 0 OHM J 1/16W		Q10,11			2SK508NV(K52)	FET	
R820			RK73GB1J473J	CHIP R 47K J 1/16W		Q12			KRX102U	TRANSISTOR	
R821			R92-1261-05	CHIP R 150 J 1/2W		Q13			2SK1824	FET	
R822,823			RK73GB1J223J	CHIP R 22K J 1/16W		Q14			2SC4617(S)	TRANSISTOR	
R824			RK73GB1J473J	CHIP R 47K J 1/16W		Q15			2SC5108(Y)	TRANSISTOR	
R825			R92-1252-05	CHIP R 0 OHM J 1/16W		Q16			KRC414RTK	DIGITAL TRANSISTOR	
R888			F53-0108-05	FUSE 1.8A 50V		Q18			2SC2412K	TRANSISTOR	
						Q19,20			2SC4649(N,P)	TRANSISTOR	
D1-4			DA221	DIODE		Q21			3SK255	FET	

TK-7102H

PARTS LIST

TX-RX UNIT (X57-6380-XX)

Ref. No.	Address	New parts	Parts No.	Description	Destination	Ref. No.	Address	New parts	Parts No.	Description	Destination
Q22			2SK1824	FET							
Q23			2SC3357	TRANSISTOR							
Q24			2SC4617(S)	TRANSISTOR							
Q25			2SC3357	TRANSISTOR							
Q26			3SK255	FET							
Q29,30			KRC102S	DIGITAL TRANSISTOR							
Q31			2SA1745(6,7)	TRANSISTOR							
Q32			DTC363EU	DIGITAL TRANSISTOR							
Q33			KTA1664(Y)	TRANSISTOR							
Q34,35			KRC102S	DIGITAL TRANSISTOR							
Q37			2SK1824	FET							
Q38			KRC404RTK	DIGITAL TRANSISTOR							
Q41			2SC4919	TRANSISTOR							
Q42			2SA1641(S,T)	TRANSISTOR							
Q43			2SK1824	FET							
Q101	2B		2SK3478-22	FET							
Q800			2SK3075	FET							
TH1			B57331V2104J	THERMISTOR							
TH3			B57331V2104J	THERMISTOR							
TH5			B57331V2104J	THERMISTOR							
TH6		*	B57321V2102J	THERMISTOR	K2,M2						

EXPLODED VIEW

- A M2.6 x 8 : N67-2608-46
- B M2.6 x 6 (Br-Tap) : N87-2606-46
- C M2.6 x 14 (Br-Tap) : N87-2614-46

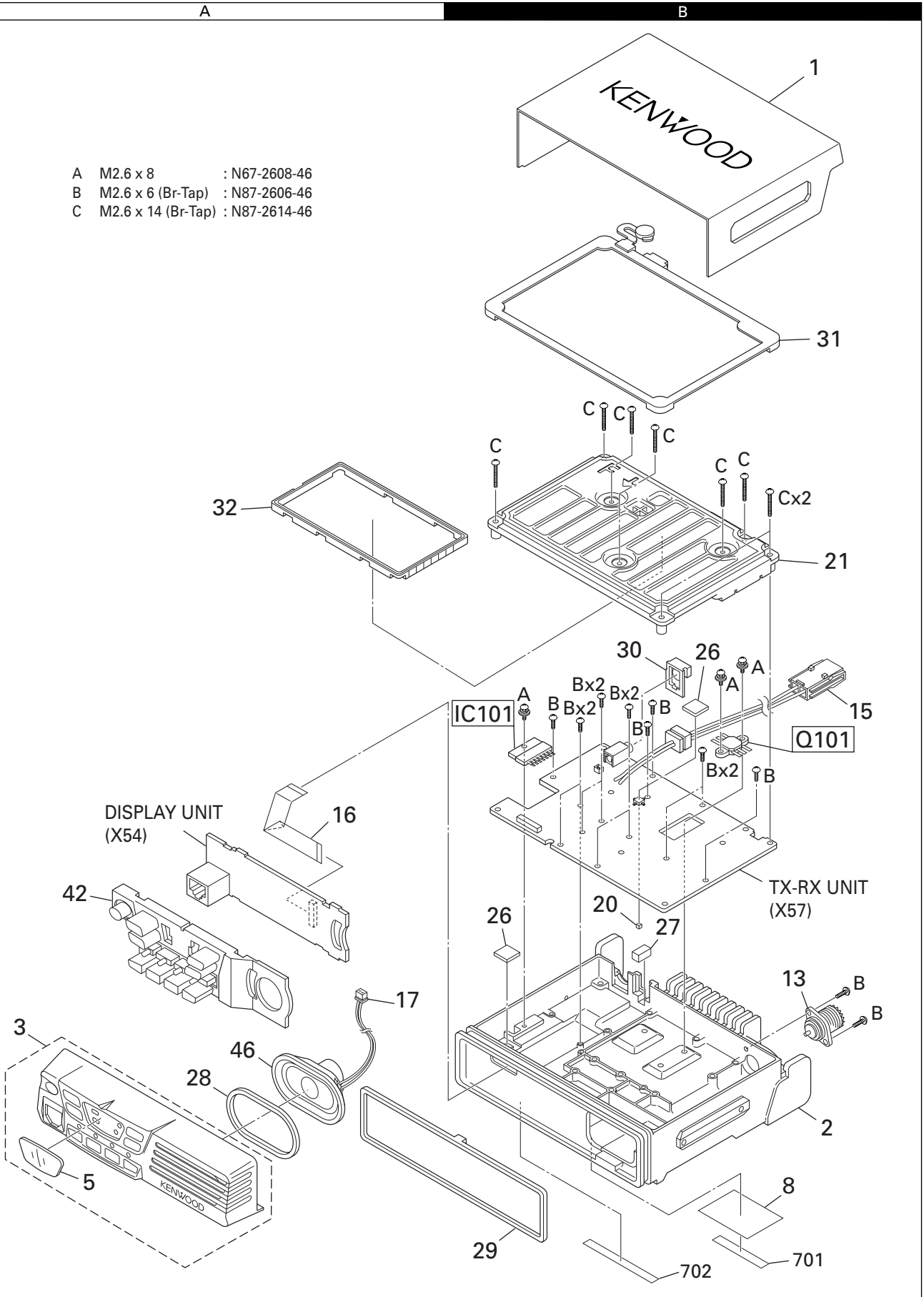

Parts with the exploded numbers larger than 700 are not supplied.

ADJUSTMENT

Test Equipment Required for Alignment

Test Equipment	Major Specifications	
1. Standard Signal Generator (SSG)	Frequency Range Modulation Output	136 to 175MHz Frequency modulation and external modulation -127dBm/0.1μV to greater than -7dBm/100mV
2. Power Meter	Input Impedance Operation Frequency Measurement Capability	50Ω 136 to 175MHz or more Vicinity of 100W
3. Deviation Meter	Frequency Range	136 to 175MHz
4. Digital Volt Meter (DVM)	Measuring Range Accuracy	1 to 20V DC High input impedance for minimum circuit loading
5. Oscilloscope		DC through 30MHz
6. High Sensitivity Frequency Counter	Frequency Range Frequency Stability	10Hz to 1000MHz 0.2ppm or less
7. Ammeter		20A
8. AF Volt Meter (AF VTVM)	Frequency Range Voltage Range	50Hz to 10kHz 1mV to 3V
9. Audio Generator (AG)	Frequency Range Output	20Hz to 20kHz or more 0 to 1V
10. Distortion Meter	Capability Input Level	3% or less at 1kHz 50mV to 10Vrms
11. 4Ω Dummy Load		Approx. 4Ω, 10W or more
12. Regulated Power Supply		13.6V, approx. 20A (adjustable from 9 to 17V) Useful if ammeter requipped
13. Spectrum Analyzer	Center frequency	50KHz to 600MHz
14. Tracking Generator	Output Voltage	100mV or more

Tuning cable (E30-3383-05)

Adapter cable (E30-3383-05) is required for injecting an audio if PC tuning is used. See "PC Mode" section for the connection.

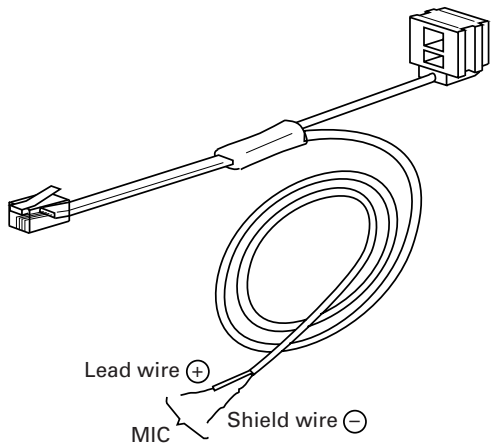

Test cable for microphone input (E30-3360-08)

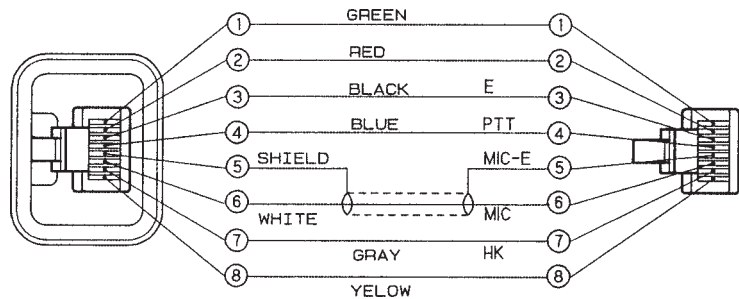

MIC connector (Front view)

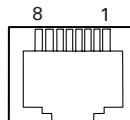

- 1 : BLC
- 2 : PSB
- 3 : E
- 4 : PTT
- 5 : ME
- 6 : MIC
- 7 : HOOK
- 8 : CM

ADJUSTMENT

Adjustment Location

■ Switch

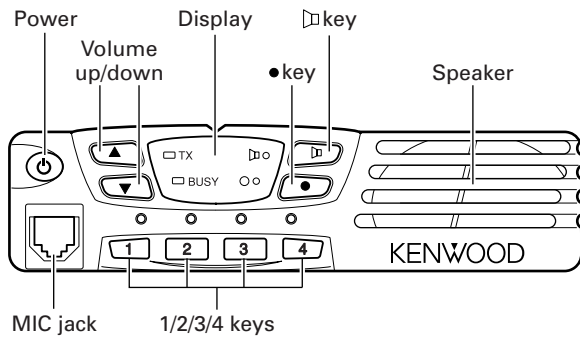

■ Adjustment Points

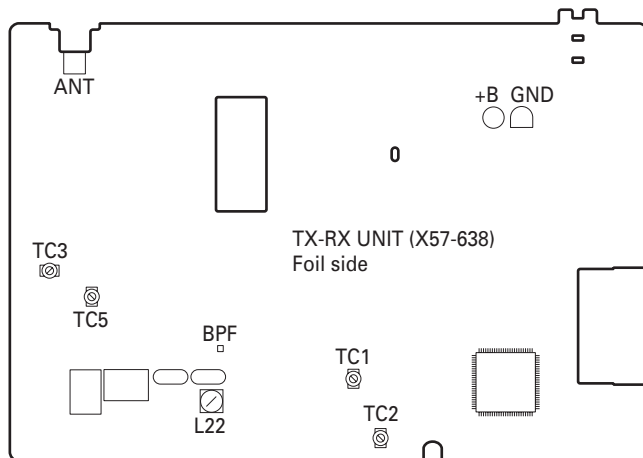
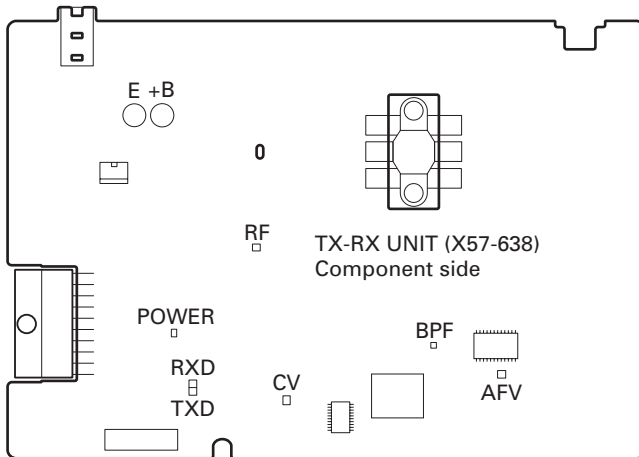

■ Note

• EEPROM

The tuning data (Deviation, Squelch, etc.) for the EEPROM, is stored in memory. When parts are changed, readjust the transceiver.

• AF PA IC (IC101)

How to mounting the IC101.

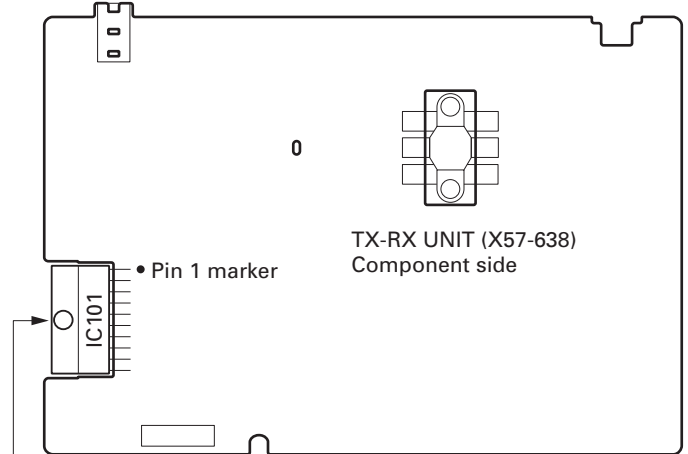

Part name label face down

• SPEAKER CABLE

The speaker cable should be formed before mounting the shield cover as below.

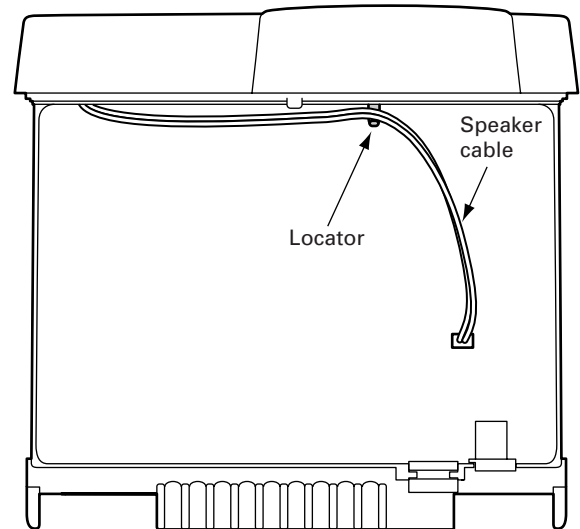

• FUSE

To mount the Fuse, the cable terminal direction must be as follows.

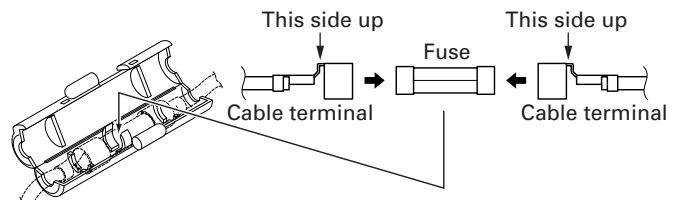

ADJUSTMENT

Replacing a Drive FET (Q800)

1. When replacing the Drive FET, you must also replace its heat conductor cube, because the heat conductor cube is removed along with the FET.
2. After removing the FET and its heat conductor cube, solder a new Drive FET to the PCB. Make sure the FET is in the proper position before soldering.
3. Attach the heat conductor cube to the FET as instructed below.

How to Solder the Heat Conductor Cube

1. Place a piece of soldering wire (about 2.5~3.0 mm long x 0.6mm diameter) into the FET hole on the PCB (①).
2. Place the heat conductor cube on the PCB surface beside the FET hole. The rounded surface of the heat conductor cube must face upward (as shown below) (②).
3. Slide and drop the cube into the FET hole so that the rounded surface of the cube is now horizontal (as shown below) (③).

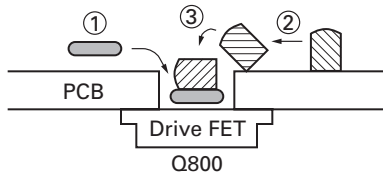

Fig. 1

4. Place a heated soldering iron onto the top of the cube, using an iron tip 900M-T-3CF. Hold the soldering iron in position for about 5 seconds (See the figure 2).

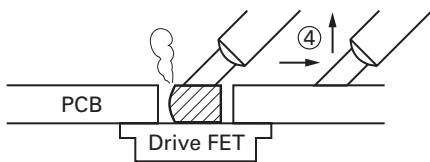
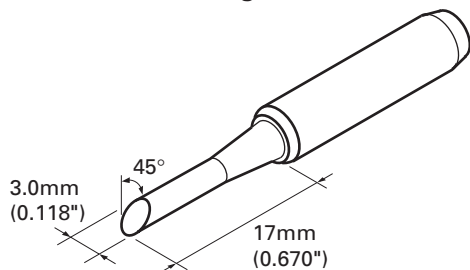

Fig. 2



900M-T-3CF

5. The solder melts and binds the FET and the cube securely. Then, slide the soldering iron along the PCB surface to cool the soldering down (④). If the heat conductor cube comes off from the PCB or the soldering can be seen on the top of the plate, the soldering has not been successful. The soldering must bind the heat conductor cube and FET securely (see the figure 3).

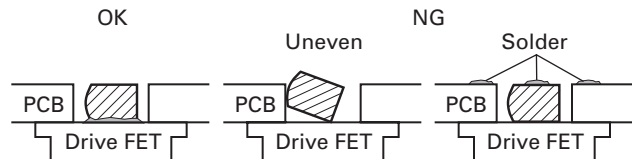

Fig. 3

6. After soldering the heat conductor cube to the PCB, check the level of PCB surface. The surface of the heat conductor cube must be free of flux and solder. It must be flat and smooth, at the same level as the PCB surface (as shown below).

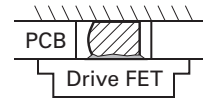

Fig. 4

How to Check the Heat Conductor Cube Surface

1. Slide your index finger along the PCB surface (as shown below) (⑤).

The surface should be flat and smooth. If you feel that the surface is uneven because of solder or flux, grind them using meshed copper or re-solder the cube in order to flatten the surface.

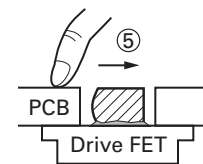

Fig. 5

Test Frequency (MHz)

Channel	K,M		K2,M2	
	TX	RX	TX	RX
1 : Center	160.100	160.050	149.100	149.050
2 : Low	146.100	146.050	136.100	136.050
3 : High	173.900	173.950	161.900	161.950
4	160.000	160.000	149.000	149.000
5	160.200	160.200	149.200	149.200
6	160.400	160.400	149.400	149.400

ADJUSTMENT

PCB Section

Item	Condition	Measurement		Adjustment		Specifications/ Remarks
		Test equipment	Terminal	Parts	Method	
1. Setting	1) Power supply voltage DC Power supply terminal : 13.6V					
2. VCO lock voltage*	1) CH : TX high	Digital voltmeter	CV	TC2	5.5V	±0.1V
	2) CH : RX high			TC1	5.5V	±0.1V
	3) CH : TX low				Check	0.8V or more
	4) CH : RX low					
3. IF coil	1) CH : RX center (Wide) 2) SSG output : -53dBm (501μV) Mod : 1kHz, Dev : 3kHz	SSG Digital voltmeter	AFV	L22	3.2~3.3V (DC)	
4. RF bandpass filter	1) CH : RX center (Wide) CH : RX low (Wide) CH : RX high (Wide) 2) Tra generator output : -30dBm Connect the spectrum analyzer to BPF terminal	Tra generator Spectrum analyzer	ANT BPF	TC3 TC5	Adjust the BPF waveform to Fig. 1	

* Adjustment of TX VCO lock voltage

1. Remove R224, R888 (fuse), R803 and R811 (all on component side).
2. Remove PCB from chassis.
3. Transmit and check voltage at [CV] point.

Warning :

- Do not transmit if step "1." is not complete.
4. Adjust of voltage can be done by tuning TC2.

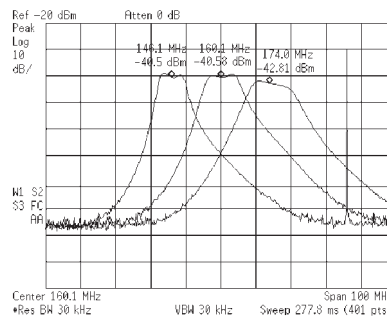

K,M

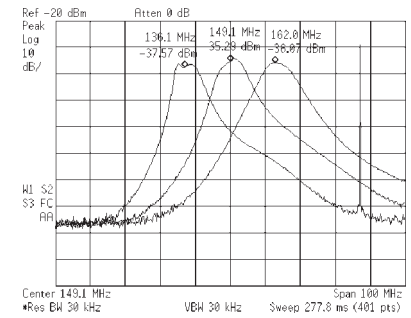

K2,M2

Fig. 1

Receiver Section

Item	Condition	Measurement		Adjustment		Specifications/ Remarks
		Test equipment	Terminal	Parts	Method	
1. Seisitivity	1) CH : RX low (Wide/Narrow) CH : RX center (Wide/Narrow) CH : RX high (Wide/Narrow) 2) SSG output : -118dBm (0.28μV) (Wide) : -116dBm (0.35μV) (Narrow) Mod : 1kHz Dev : ±3.0kHz (Wide) Dev : ±1.5kHz (Narrow)	SSG Oscilloscope AF V.M Distortion meter	ANT EXT. SP		Check	SINAD : 12dB or higher
2. Squelch 9	1) CH : RX low (Wide) CH : RX center (Wide/Narrow) CH : RX high (Wide) 2) SSG output : -113dBm (0.5μV) (Wide) : -112dBm (0.56μV) (Narrow) Mod : 1kHz Dev : ±3.0kHz (Wide) Dev : ±1.5kHz (Narrow)			PC key	Adjust to open the squelch	
3. Squelch 1	1) CH : RX low (Wide) CH : RX center (Wide/Narrow) CH : RX high (Wide) 2) SSG output : -120dBm (0.22μV) (Wide) : -119dBm (0.25μV) (Narrow) Mod : 1kHz Dev : ±3.0kHz (Wide) Dev : ±1.5kHz (Narrow)					

ADJUSTMENT

Transmitter Section

Item	Condition	Measurement		Adjustment		Specifications/ Remarks
		Test equipment	Terminal	Parts	Method	
1. Frequency	1) CH : TX center 2) Transmit	Frequency counter	ANT	PC key	Adjust to center frequency	Within $\pm 100\text{Hz}$
2. High power	1) CH : TX low CH : TX low' CH : TX center CH : TX high' CH : TX high 2) Transmit	Power meter			50W	$\pm 1.0\text{W}$
3. Low power	1) CH : TX low CH : TX low' CH : TX center CH : TX high' CH : TX high 2) Transmit				25W	$\pm 1.0\text{W}$
4. DQT balance	1) CH : TX low (Wide) CH : TC center (Wide/Narrow) CH : TX high (Wide) 2) Transmit				Modulation analyzer or Linear detector (LPF : 3kHz) Oscilloscope	Adjust the waveform as below 
5. MAX balance	1) CH : TX low (Wide) CH : TC center (Wide/Narrow) CH : TX high (Wide) 2) AG : 1kHz/50mV 3) Transmit	Modulation analyzer or Linear detector (LPF : 15kHz) Oscilloscope AG	ANT MIC	$\pm 4.0\text{kHz}$ (Wide) $\pm 2.0\text{kHz}$ (Narrow) According to the large +, -	$\pm 50\text{Hz}$	
6. MIC sensitivity	1) CH : TX center (Wide/Narrow) 2) AG : 1kHz/5mV 3) Transmit	AF V.M		Check	$\pm 3\text{kHz} \pm 0.2\text{kHz}$ (Wide) $\pm 1.5\text{kHz} \pm 0.1\text{kHz}$ (Narrow)	
7. DQT deviation	1) CH : TX low (Wide) CH : TX center (Wide/Narrow) CH : TX high (Wide) 2) Transmit	Modulation analyzer or Linear detector (LPF : 3kHz) Oscilloscope		$\pm 0.75\text{kHz}$ (Wide) $\pm 0.35\text{kHz}$ (Narrow)	$\pm 0.05\text{kHz}$	
8. QT deviation	1) CH : TX low (Wide) CH : TX center (Wide/Narrow) CH : TX high (Wide) 2) Transmit			$\pm 0.75\text{kHz}$ (Wide) $\pm 0.35\text{kHz}$ (Narrow)	$\pm 0.05\text{kHz}$	
9. DTMF deviation	1) CH : TX center (Wide/Narrow) 2) Transmit			$\pm 3.0\text{kHz}$ (Wide) $\pm 1.5\text{kHz}$ (Narrow)	$\pm 0.2\text{kHz}$	

If normal power is not obtained, please follow the step below

Open the shielding cover (upper), and screw 3 locations around ANT pin.

- Switch off the transceiver.
Impedance of Final FET (Q101) and Drive FET (Q800) can be measured easily using DVM Ω mode.
Normal condition – Gate : $2\text{M}\Omega \sim$, Drain : $20\text{k}\Omega \sim 50\text{k}\Omega$
The above impedance values are rough estimations.
- Switch on the transceiver. Check the voltage at R888 (fuse) output point.
The voltage is around 13.6V in receiving condition. The voltage will be 12.6V~ in transmitting condition. If found 0V at this point then R888 (fuse) is broken.
- Remove R224.

- Connect 50Ω load at the ANT location.
Transmit and check current drain at High power mode.
If the current drain is less than 1A, then Final FET is broken.
If the current drain is less than 5.0A, short the Drive FET gate to ground, and check the current drain.
If the current drain is not 0.1A less than the original value, then the Drive FET is broken.
- Check input power level at Drive FET gate location.
Connect the wire to [RF] location.
Transmit and check for power to be within the range of $0.3\text{W} \sim 0.6\text{W}$.
If power found is less than 0.3W, check the circuit before the Drive FET.

PC BOARD VIEWS TK-7102H

DISPLAY UNIT (X54-3340-20) Component side view (J72-0790-12)

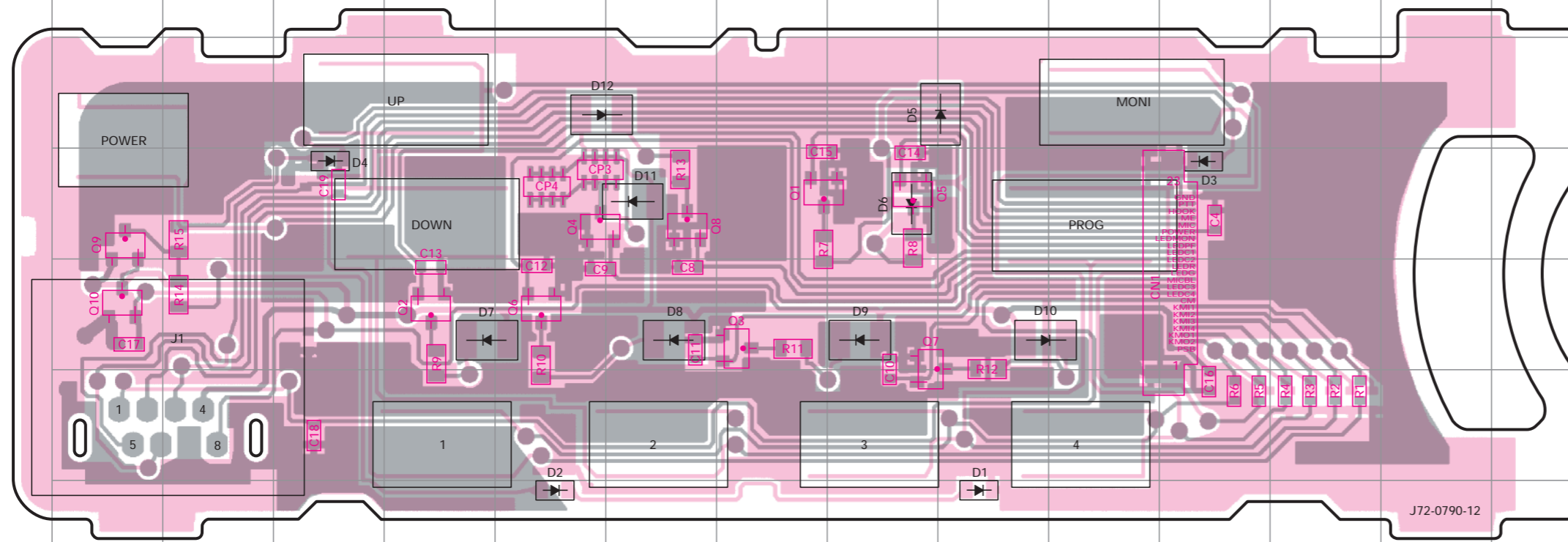

Ref. No.	Address	Ref. No.	Address	Ref. No.	Address	Ref. No.	Address	Ref. No.	Address	Ref. No.	Address
Q1	3G	Q5	3H	Q9	3A	D3	3K	D7	4D	D11	3F
Q2	4D	Q6	4E	Q10	4A	D4	3C	D8	4F	D12	2E
Q3	4G	Q7	4H	D1	6I	D5	2I	D9	4H		
Q4	3E	Q8	3F	D2	6E	D6	3H	D10	4I		

DISPLAY UNIT (X54-3340-20) Foil side view (J72-0790-12)

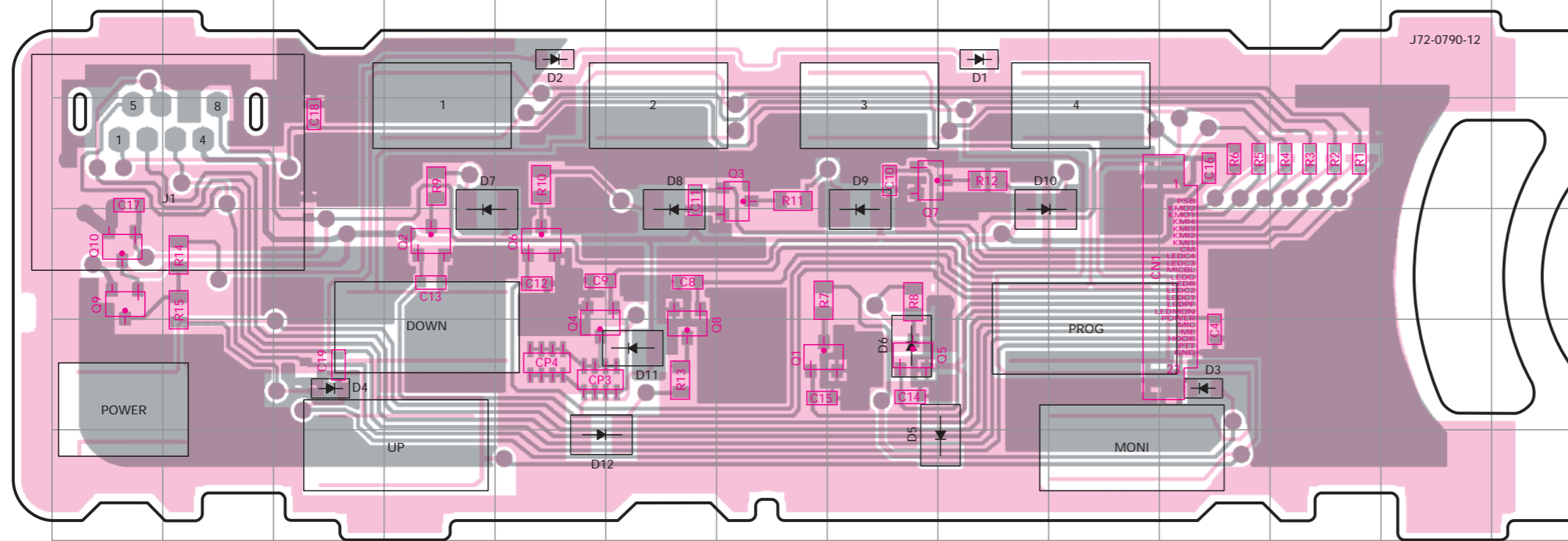

Ref. No.	Address	Ref. No.	Address	Ref. No.	Address	Ref. No.	Address	Ref. No.	Address	Ref. No.	Address
Q1	11G	Q5	11H	Q9	10A	D3	11K	D7	10D	D11	11F
Q2	10D	Q6	10E	Q10	10A	D4	11C	D8	10F	D12	12E
Q3	9G	Q7	9H	D1	8I	D5	12I	D9	10H		
Q4	11E	Q8	11F	D2	8E	D6	11H	D10	10I		

Component side
Foil side

- KRC404RTK
- KRC414RTK
- 2SA1745
- 2SA1832
- 2SC2412K
- 2SC4617
- 2SC4738
- 2SC5108
- DA221
- MA742
- 2SK508NV
- 3SK255
- 2SA1641
- KTA1664
- DTC363EU
- KRA225S
- KRC102S
- 2SC4649
- 2SC4919
- LA4600
- TC7W74FU
- NJM2100V
- NJM2904V
- UPB1509GV
- 24LC08BT-ISN
- TA75W01FU
- LC73872M
- NJM2902V
- KIA7808AF
- TK14489V
- 2SK3075
- 2SK3478-22
- PST9140NR
- MR15A07
- NJM78L05UA

TK-7102H PC BOARD VIEW

TX-RX UNIT (X57-6380-XX) -20 : K,M -21 : K2,M2 Component side view (J72-0829-12)

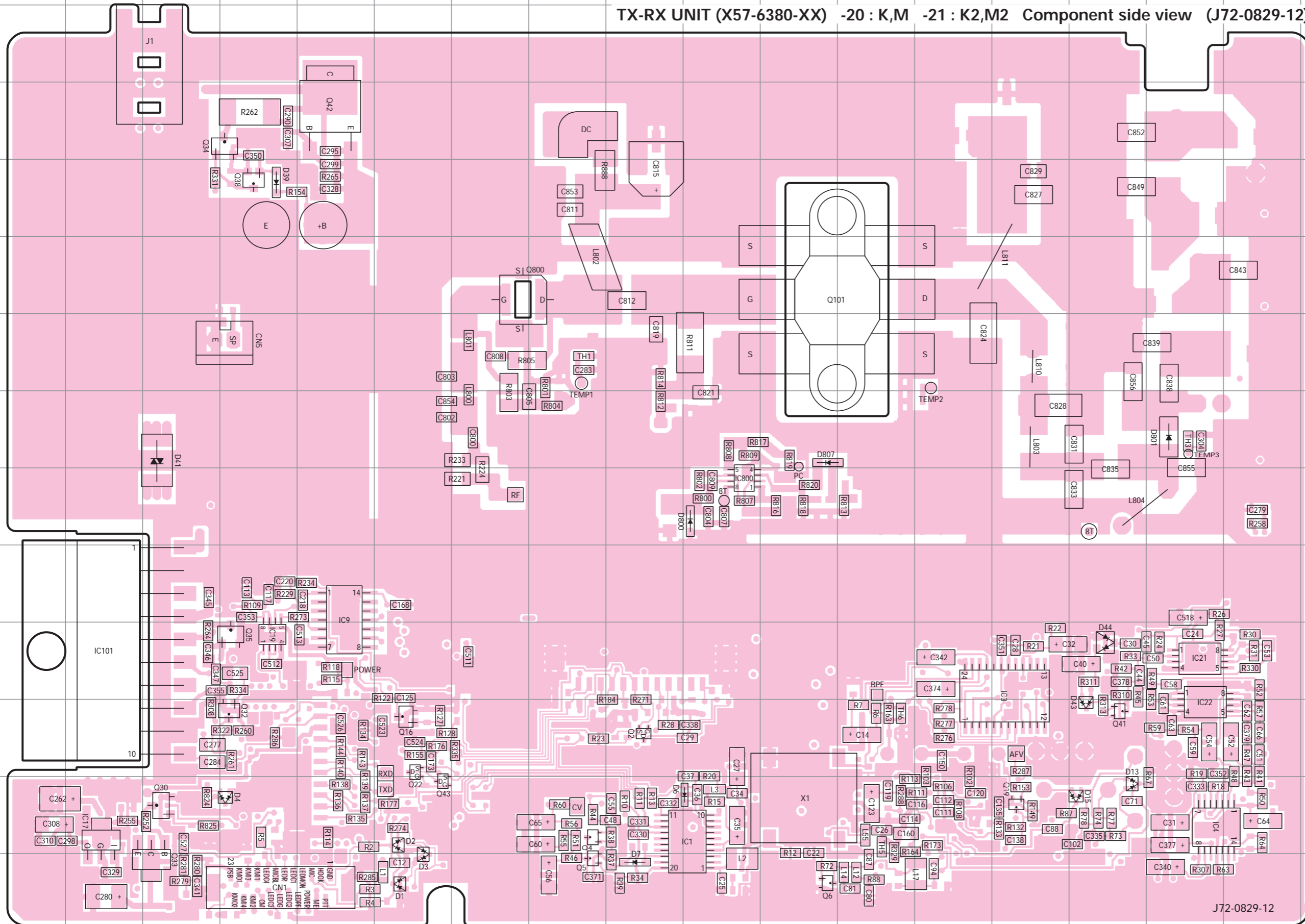

Ref. No.	Address
IC1	12J
IC3	10N
IC4	12P
IC9	9E
IC17	12B
IC19	10D
IC21	10P
IC22	11P
IC101	10B
IC800	8J
Q2	11I
Q4	12H
Q5	13H
Q6	13K
Q16	11F
Q19	12N
Q22	11F
Q30	12C
Q32	11D
Q33	13C
Q34	3D
Q35	10D
Q38	4D
Q41	11O
Q42	3E
Q43	12F
Q101	5K
Q800	5G
D1	13F
D2	12F
D3	12F
D4	12D
D6	12J
D7	13I
D13	12O
D15	12O
D39	4D
D41	7C
D43	11O
D44	10O
D800	8J
D801	7P
D807	7K

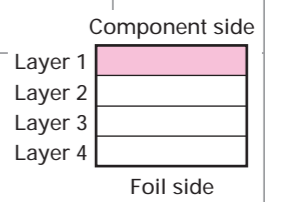

PC BOARD VIEW TK-7102H

TX-RX UNIT (X57-6380-XX) -20 : K,M -21 : K2,M2 Foil side view (J72-0829-12)

Ref. No.	Address
IC5	12G
IC6	11O
IC7	12N
IC10	12C
IC11	12E
IC14	13Q
IC15	13N
IC18	12N
IC20	12R
IC23	13H
Q3	12J
Q7	11J
Q10	11K
Q11	13L
Q12	11J
Q13	10P
Q14	12J
Q15	12K
Q18	13G
Q20	12I
Q21	10H
Q23	10K
Q24	11C
Q25	10M
Q26	10D
Q29	12Q
Q31	12R
Q37	10O
D9	11L
D10	12L
D11	11L
D12	12L
D14	12L
D16	12J
D18	13H
D19	10I
D20	10K
D21	10F
D22	10D
D23	10L
D24	13E
D25	9D
D26	8C
D38	3O
D803	7C
D804	7D
D805	5C
D806	4D

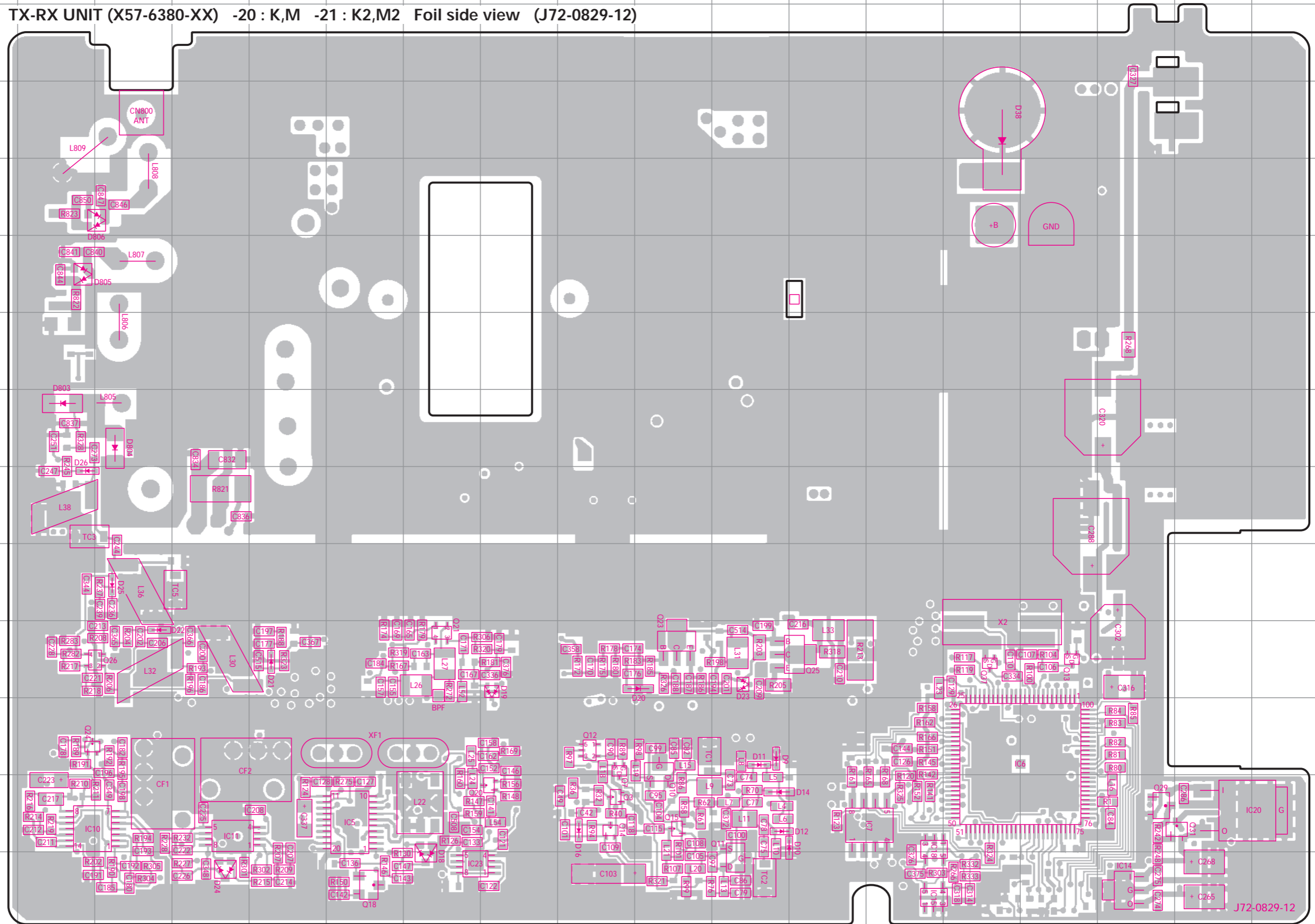
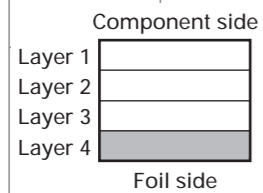

TK-7102H PC BOARD VIEW

TX-RX UNIT (X57-6380-XX) -20 : K,M -21 : K2,M2 Component side view + Foil side (J72-0829-12)





Ref. No.	Address	Ref. No.	Address
IC1	12J	Q33	13C
IC3	10N	Q34	3D
IC4	12P	Q35	10D
IC5	12M	Q37	10E
IC6	11D	Q38	4D
IC7	12F	Q41	11O
IC9	9E	Q42	3E
IC10	12Q	Q43	12F
IC11	12O	Q101	5K
IC14	13C	Q800	5G
IC15	13F	D1	13F
IC17	12B	D2	12F
IC18	12F	D3	12F
IC19	10D	D4	12D
IC21	10P	D7	13I
IC22	11P	D9	11H
IC23	13L	D10	12G
IC101	10B	D11	11H
IC800	8J	D12	12H
Q2	11I	D13	12O
Q3	12J	D14	12H
Q4	12H	D15	12O
Q5	13H	D16	12J
Q6	13K	D18	13L
Q7	11J	D19	10K
Q10	11I	D20	10I
Q11	13H	D21	10N
Q12	11J	D22	10P
Q13	10D	D23	10H
Q14	12J	D24	13O
Q15	12I	D25	9P
Q16	11F	D26	8Q
Q18	13M	D38	3E
Q19	12N	D39	4D
Q20	12K	D41	7C
Q21	10L	D43	11O
Q22	11F	D44	10O
Q23	10I	D305	5Q
Q24	11Q	D800	8J
Q25	10G	D801	7P
Q26	10P	D803	7Q
Q29	12C	D804	7P
Q30	12C	D806	4P
Q31	12B	D807	7K
Q32	11D		

Component side

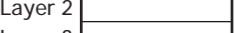
Layer 1 

Layer 2 

Layer 3 

Layer 4 

Foil side

● Connect 1 and 4

Note : Component marked with a dot (●) are parts of layer 1.

SCHEMATIC DIAGRAM TK-7102H

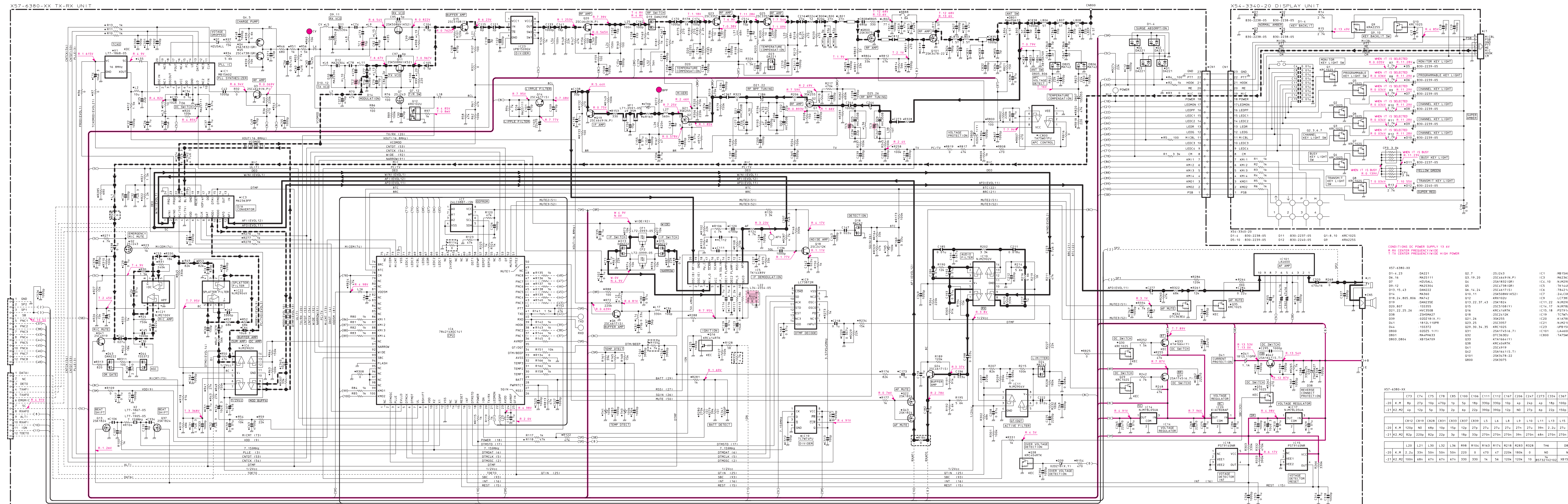

TK-7102H TK-7102H

LEVEL DIAGRAM

Receiver Section

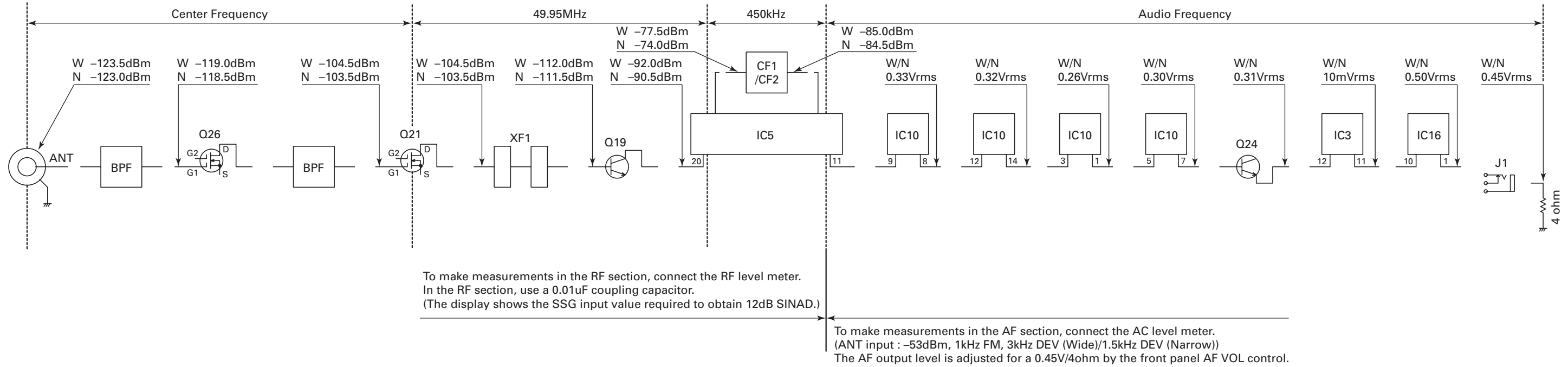

Transmitter Section

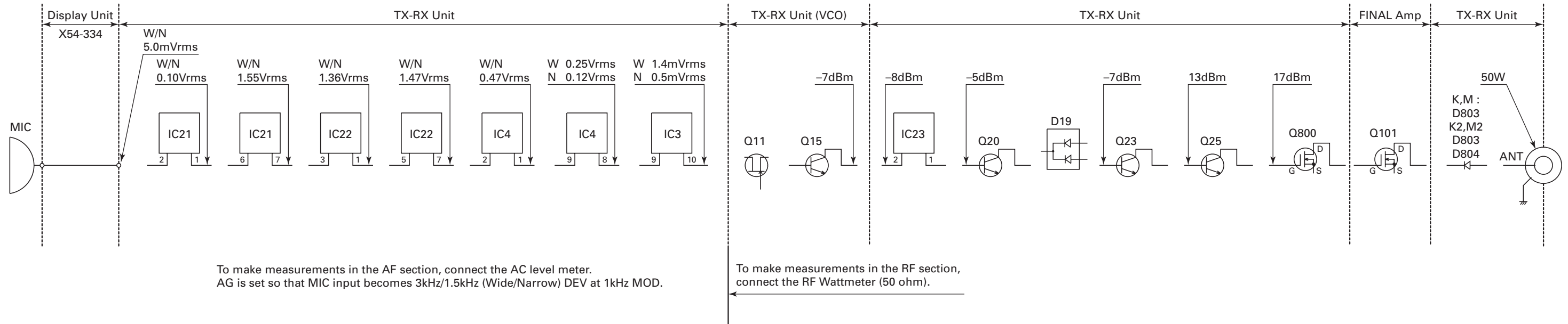

SPECIFICATIONS

GENERAL

Frequency Range	K,M : 146 to 174MHz	K2,M2 : 136 to 162MHz
Number of Channels	4 channels	
Channel Spacing	Wide : 25kHz	Narrow : 12.5kHz
PLL Channel Stepping	2.5, 5, 6.25, 7.5kHz	
Operating Voltage	13.6V DC \pm 15%	
Current Drain	Less than 0.4A on standby	
	Less than 1.0A on receive	
	Less than 14.0A on transmit	
Operating Temperature Range	-30°C to +60°C	
Dimensions & Weight	6.30 (160) W x 1.70 (43) H x 5.40 (137) D inch (mm), 2.60 lbs (1.18kg)	
Channel Frequency Spread	K,M : 28MHz	K2,M2 : 26MHz

RECEIVER (Measurements made per EIA standard EIA/TIA-603)

Sensitivity (12dB SINAD)	Wide : 0.28 μ V	Narrow : 0.35 μ V
Selectivity	Wide : 75dB	Narrow : 65dB
Intermodulation	Wide : 70dB	Narrow : 60dB
Spurious Response	75dB	
Audio Power Output	4.0W	
Frequency Stability	\pm 2.5ppm	

TRANSMITTER (Measurements made per EIA standard EIA/TIA-603)

RF Power Output	50W	
Spurious and Harmonics	70dB	
Modulation	Wide : 16K0F3E	Narrow : 11K0F3E
FM Noise	Wide : 45dB	Narrow : 40dB
Audio Distortion	Less than 3%	
Frequency Stability	\pm 2.5ppm	

TK-7102H

KENWOOD CORPORATION

14-6, Dogenzaka 1-chome, Shibuya-ku, Tokyo 150-8501, Japan

KENWOOD SERVICE CORPORATION

P.O. BOX 22745, 2201 East Dominguez Street, Long Beach, CA 90801-5745, U.S.A.

KENWOOD ELECTRONICS CANADA INC.

6070 Kestrel Road, Mississauga, Ontario, Canada L5T 1S8

KENWOOD ELECTRONICS DEUTSCHLAND GMBH

Rembrücker Str. 15, 63150 Heusenstamm, Germany

KENWOOD ELECTRONICS BELGIUM N.V.

Leuvensesteenweg 248 J, 1800 Vilvoorde, Belgium

KENWOOD ELECTRONICS FRANCE S.A.

13, Boulevard Ney, 75018 Paris, France

KENWOOD ELECTRONICS U.K. LIMITED

KENWOOD House, Dwight Road, Watford, Herts., WD1 8EB United Kingdom

KENWOOD ELECTRONICS EUROPE B.V.

Amsterdamseweg 37, 1422 AC Uithoorn, The Netherlands

KENWOOD ELECTRONICS ITALIA S.p.A.

Via G. Sirtori, 7/9 20129 Milano, Italy

KENWOOD IBERICA S.A.

Bolivia, 239-08020 Barcelona, Spain

KENWOOD ELECTRONICS AUSTRALIA PTY. LTD.

(A.C.N. 001 499 074)

16 Giffnock Avenue, Centrecourt Estate, North Ryde, N.S.W. 2113 Australia

KENWOOD ELECTRONICS (HONG KONG) LTD.

Unit 3712-3724, Level 37, Tower one Metroplaza, 223 Hing Fong Road, Kwai Fong, N.T., Hong Kong

KENWOOD ELECTRONICS TECHNOLOGIES(S) PTE LTD.

Sales Marketing Division

1 Ang Mo Kio Street 63, Singapore 569110

